

Press release

Liebherr 36 XXT truck mounted concrete pump at Conexpo 2023: Light, compact, flexible

- The new Liebherr 36 XXT truck mounted concrete pump with a five-part multi-fold distributor boom
- It comes equipped with the unique Liebherr Powerbloc drive unit
- The semi-closed oil circuit offers a multitude of benefits

Innovative technologies have been combined in a compact machine: The new 36 XXT truck mounted concrete pump combines the advantages of the new five-part folding boom with the Powerbloc drive unit and the semi-closed oil circuit. The machine has also been given a new and appealing look.

Las Vegas (USA), March 14, 2023 – Following extensive testing, sales of Liebherr's completely newly developed 36 XXT truck mounted concrete pump are now starting in the USA. The result: A versatile machine, packed with technical innovations from Liebherr. A large number of the pump operators' wishes were considered, such as ergonomic access steps, simplified accessibility and an expansion of the stowage and storage options.

An extremely compact assembly with no boom overhang at the rear ensures high maneuverability in confined spaces. The machine is weight-optimized and therefore travels with a total weight of approximately 28,7 Ust (26 tonnes) on three axles, depending on the equipment. The XXT support ensures perfect stability. It shows its strengths particularly when it comes to narrow supports, so confined spaces are no problem. The modern radio remote control allows sensitive boom movements. The clear color display shows the operator all important parameters.

The new five-part boom allows maximum flexibility on the construction site. Especially when concreting in buildings, the boom proves to have very good slip properties. The five arms make it easy to reach a wide variety of positions on the construction site. The design and kinematics of the boom ensure low-vibration and even work when placing concrete.

The shape of the charging hopper favors a uniform flow of concrete and very good suction behavior. Two separately driven agitators push the concrete directly into the suction area, which works perfectly even with concrete types that are difficult to pump.

Unique Powerbloc drive unit

A major highlight of the new 36 XXT is Liebherr's newly developed "Powerbloc" pump drive unit. It is characterized by the fact that all hydraulic switching and measuring elements are fully integrated. This eliminates the need for numerous hydraulic hoses and other components previously required. The drive unit is therefore a special kind in the concrete pump world. Features of the new system are its robustness, high performance and quiet running.

Semi-closed oil circuit (HCC)

The new drive unit is combined with the highly efficient semi-closed oil circuit, which supplies all drives powerfully and reliably with hydraulic energy. As a result, the oil volume could be significantly reduced. The new Liebherr system combines the advantages of the proven open and closed circuits currently on the market, without their respective disadvantages. Customers confirm the quiet and powerful operation of the pump unit.

The extensive accessories catalogue, allow customers to fulfil any necessary orders: For example, state-of-the-art LED lighting designs for optimal work in the dark, various storage boxes for materials and tools as well as shelves for extension hoses are available.

About Liebherr USA, Co.

Liebherr USA, Co. based in Newport News, VA provides sales and service on behalf of ten different Liebherr product segments: earthmoving, material handling, mining, mobile and crawler cranes, tower cranes, concrete technology, deep foundation machines, maritime cranes; components, and refrigeration and freezing.

About the Liebherr Group

The Liebherr Group is a family-run technology company with a highly diversified product portfolio. The company is one of the largest construction equipment manufacturers in the world. It also provides high-quality and user-oriented products and services in a wide range of other areas. The Liebherr Group includes over 140 companies across all continents. In 2021, it employed more than 49,000 staff and achieved combined revenues of over 11.6 billion euros. Liebherr was founded in Kirchdorf an der Iller in Southern Germany in 1949. Since then, the employees have been pursuing the goal of achieving continuous technological innovation, and bringing industry-leading solutions to its customers.

Images



liebherr-pump-36-XXT.jpg

The new truck mounted concrete pump 36 XXT is a versatile machine.

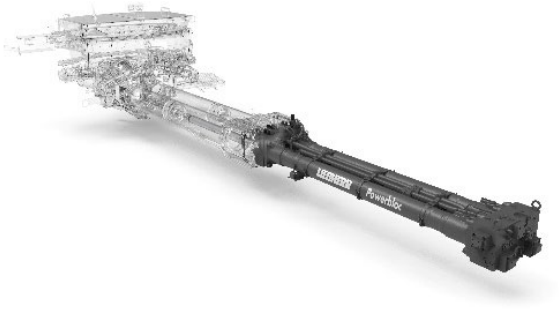

liebherr-powerbloc.jpg

The powerful Powerbloc pumping unit stands out with its quiet running.

Contact person

Klaus Eckert
Head of Marketing
Liebherr-Mischtechnik GmbH
E-Mail: klaus.eckert@liebherr.com
Phone: +49 7583 949 328

Ana Cabiedes
Head of Marketing
Liebherr USA, Co.
E-Mail: ana.cabiedes@liebherr.com
Phone: +1 (757) 928 2503

Published by

Liebherr-Mischtechnik GmbH
Bad Schussenried, Germany
www.liebherr.com