

Piling Rig

LRH 100
Litronic®

EN

LRH 3001.05



LIEBHERR

Concept and characteristics

LRH 100

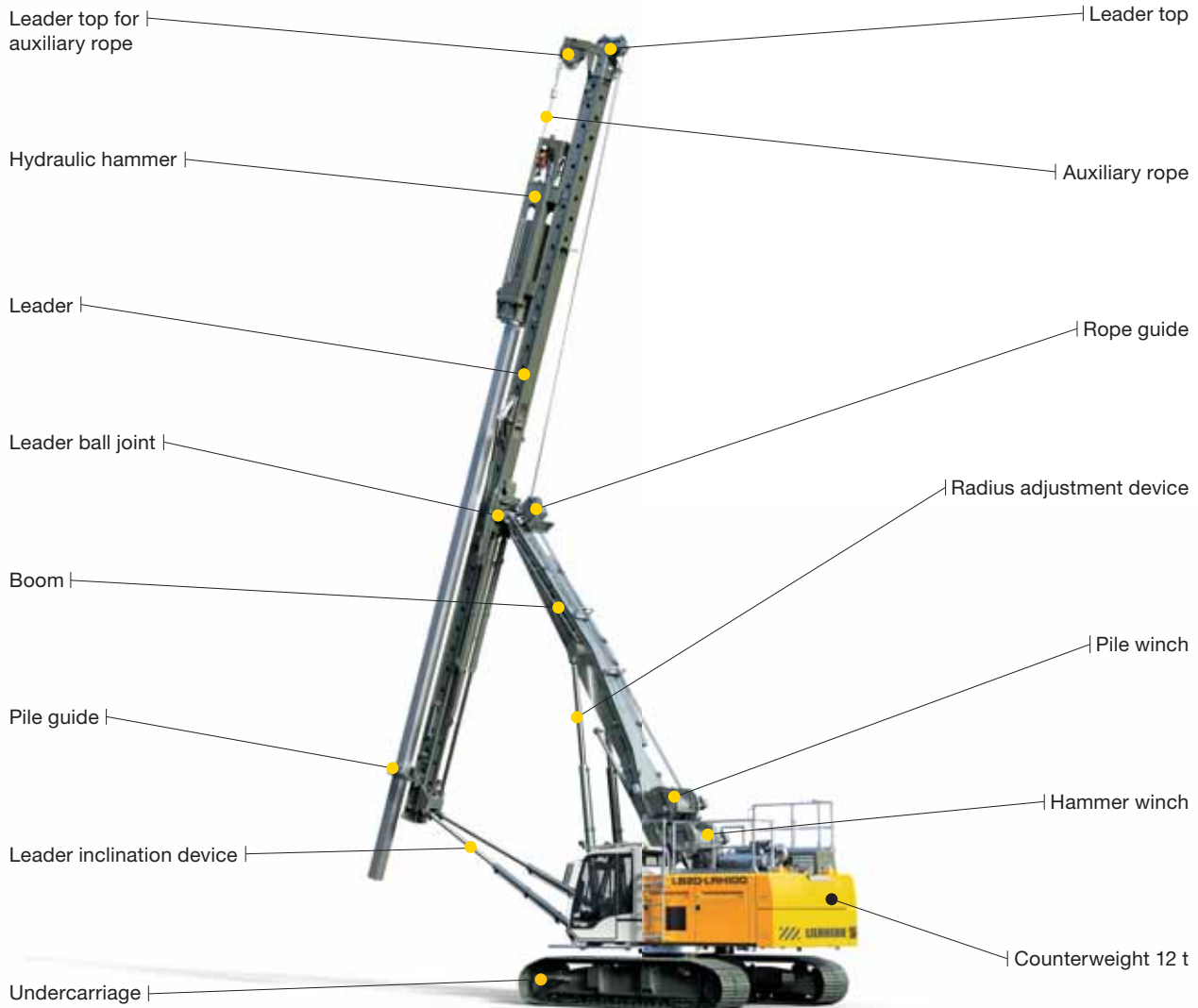

- The LRH 100 is based on the well-proven LB 20 basic machine
- Thanks to the special leader kinematics a radius of 8.75 m as well as a continuous inclination adjustment of 1:3 in all directions is achieved
- The flexible hammer design offers the possibility of mounting drop weights between 2.5 t and 7 t. This guarantees optimum adaptation to the required pile type
- A new joystick design allows for leader movements to be carried out at all times and simultaneously to other machine movements
- Automatic vertical leader alignment at the push of a button
- Automatic parallel adjustment in both axes
- Automatic slack rope prevention
- Transport fully assembled with or without mounted hammer
- Completely self-rigging (no auxiliary machines required)
- Simultaneous control of several movements via Load-sensing multi-circuit hydraulics
- Small rear swing radius
- Equipment design according to latest European regulations and standards
- High manufacturing quality through quality control by PDE system
- Evaluation and visualisation using the new Liebherr process data report software (PDR)

Dimension and weights

LRH 100

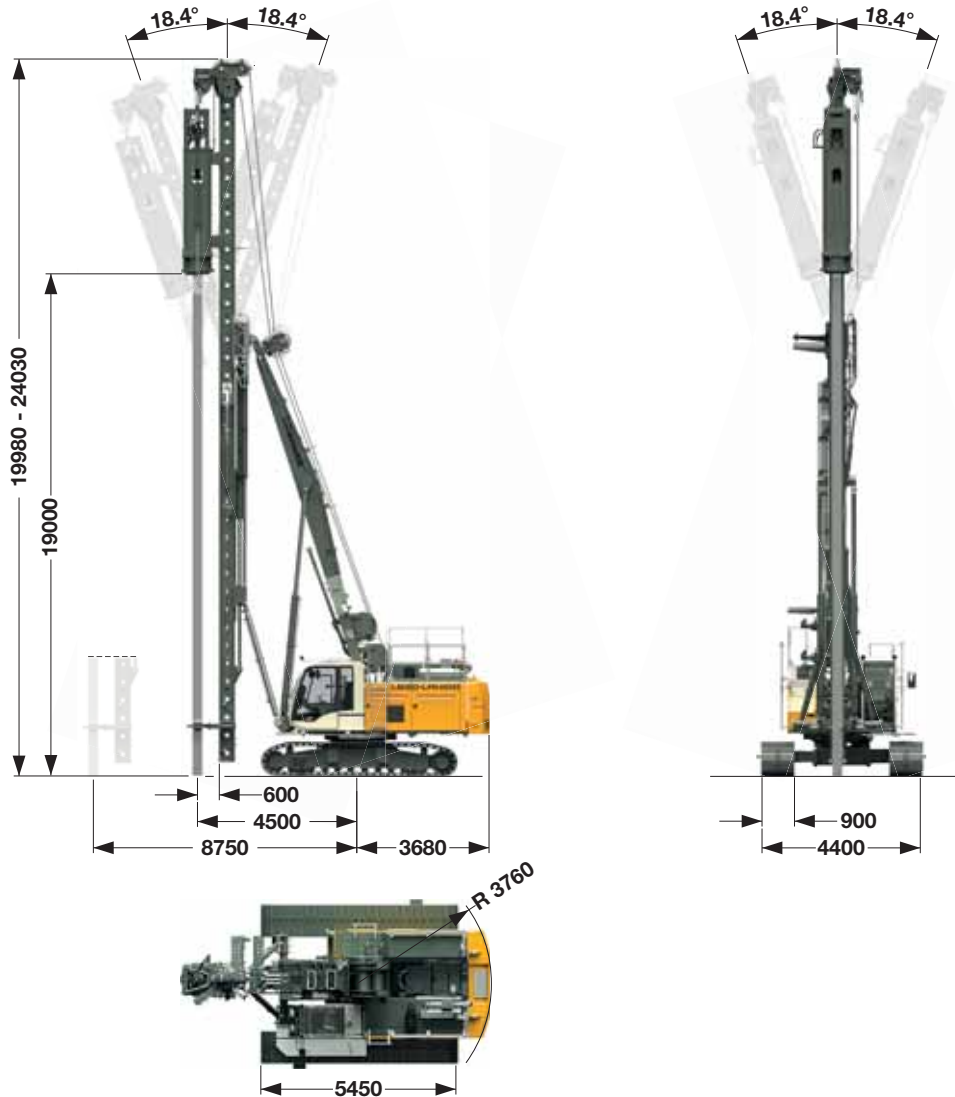

Technical data

Total height	19.98 - 24.03 m
Max. pile length	19.0 m
Drop weight*	2500 - 7000 kg
Hammer weight incl. drop weight*	5600 - 10400 kg
Leader inclination continuously variable	
Lateral inclination	± 18.4°
Forward inclination	18.4°
Backward inclination	18.4°

*) See table on page 6

Operating weight

Total weight with 900 mm 3-web grousers	65 t
Weight of hydraulic hammer H 40	see table on page 6
The operating weight includes the basic machine (hydraulic hammer H 40/2.5 with 5.6 t dead weight) and 12 t counterweight.	

Transport dimensions and weights

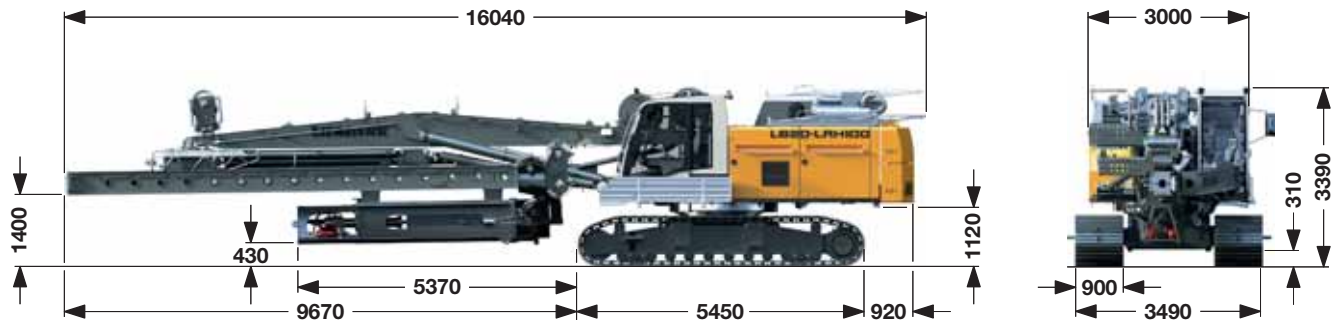

Transport - with hydraulic hammer

includes the basic machine (ready for operation) with leader, hydraulic hammer type H 40 and counterweight.

Weights

Weight complete with hydraulic hammer and counterweight — 65 t
 Weight of hydraulic hammer — see table on page 6
 The operating weight includes the basic machine (hydraulic hammer H 40/2.5 with 5.6 t dead weight) and 12 t counterweight.



Transport - standard

includes the basic machine (ready for operation) with leader without working tools and counterweight.

Weights

Weight complete without counterweight — 47.5 t

Weights can vary with the final configuration of the machine.

Transport dimensions and weights

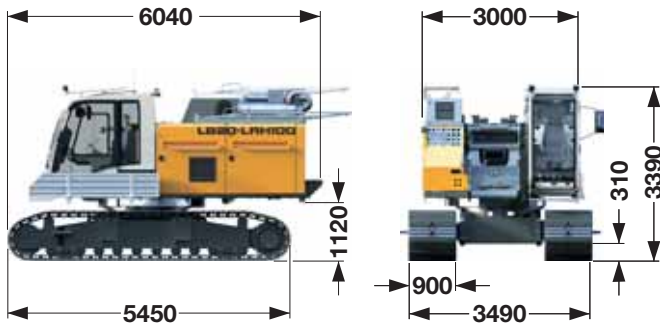

Transport basic machine

ready for operation, without counterweight.

Transport weight ————— 31.5 t

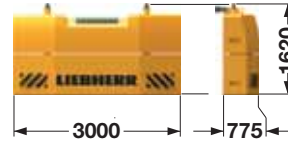

Counterweight

Counterweight ——— 6 t + 6 t

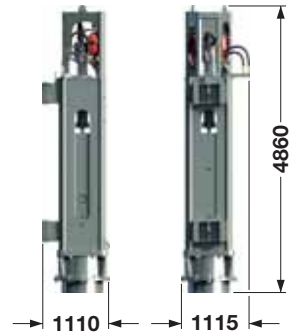

Hammer

Transport weight

H 40/2.5 ————— 5.6 t

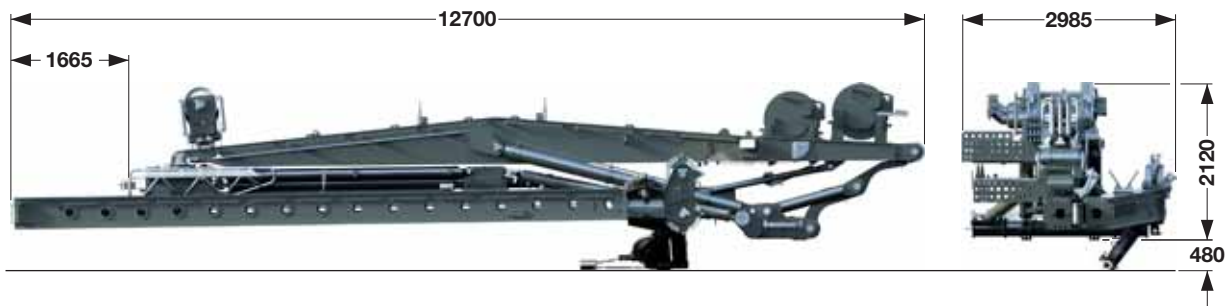

Transport leader

includes the leader without working tools (hydraulic hammer, pre-drill etc.).

Weights

Weight complete ————— 16 t

The figures include options which are not within the standard scope of supply of the rig.

Weights can vary with the final configuration of the machine.

Hydraulic hammer

H40

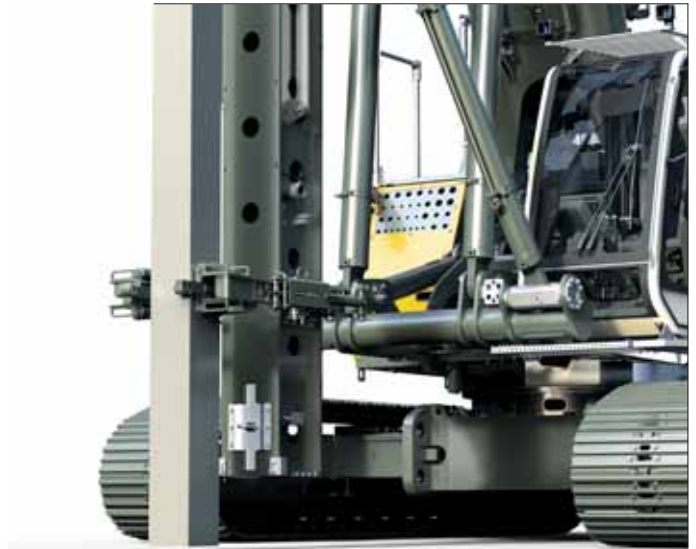

Pile with pile guide

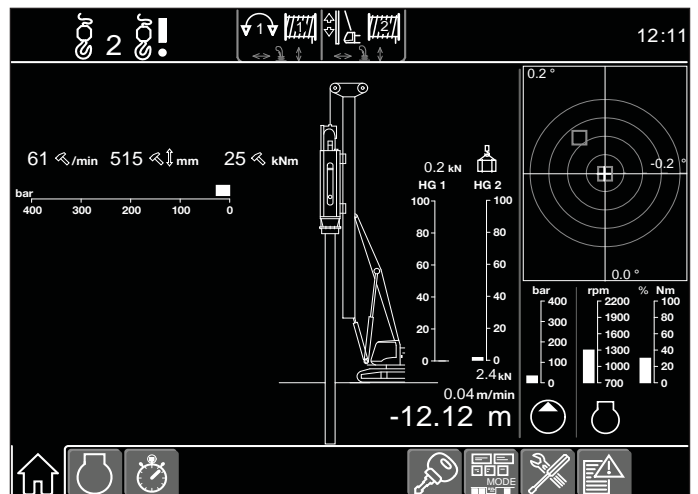

Display for hydraulic hammer

Technical data H40

Hammer type	H 40/2.5	H 40/4	H 40/5	H 40/7*
Drop weight	2500 kg	4000 kg	5000 kg	7000 kg
Max. rated energy	20 kNm	30 kNm	40 kNm	55 kNm
Blow rate - blows/min	55-80	50-80	50-80	40-80
Hammer weight incl. drop weight	5600 kg	7100 kg	8100 kg	10400 kg

*) Only in combination with extension hammer cage

Various drive cap sizes between 400 mm and 700 mm diameter available on request.

Pre-drill

BA 12



Auger with auger guide

Technical data

Rotary drive - torque	0 – 12 kNm
Rotary drive - speed	0 – 65 U/min
Max. drilling diameter	0 – 350 mm

Other drilling diameters available on request.

Technical data



Engine

Engine type ————— Liebherr D 936 A7-04
Power rating to ISO 9249 — 250 kW (335 hp) at 1700 rpm
Fuel tank ————— 700 l capacity with continuous level indicator and reserve warning

Engine complies with NRMM exhaust certification EPA/CARB Tier 4f and 97/68 EC Stage IV.



Hydraulic system

The main pumps are operated by a distributor gearbox. Axial piston displacement pumps work in open circuits supplying oil only when needed (flow control on demand). The hydraulic pressure peaks are absorbed by the integrated automatic pressure compensation, which relieves the pump and saves fuel.

Pumps for working tools ————— 2x 240 l/min
Separate pump for kinematics ————— 137 l/min
Hydraulic oil tank ————— 600 l
Max. working pressure ————— 350 bar

The cleaning of the hydraulic oils occurs via an electronically monitored pressure and return filter. Any clogging is shown on the monitor in the cab. The use of synthetic environmentally friendly oil is also possible.



Crawlers

Propulsion through axial piston motor, hydraulically released spring loaded multi-disc brake, maintenance-free crawler tracks, hydraulic chain tensioning device.

Drive speed of telescopic undercarriage ————— 0 – 1.8 km/h
Track force ————— 460 kN
Width of 3-web-grousers ————— 900 mm
Transport width ————— 3490 mm



Swing

Swing ring with triple row roller bearing, external teeth and one swing drive, fixed axial piston hydraulic motor, spring loaded and hydraulically released multi-disc holding brake, planetary gearbox and pinion. Selector for 3 speed ranges to increase swing precision.
Swing speed from 0 – 3.5 rpm is continuously variable.



Control

The control system - developed and manufactured by Liebherr - is designed to withstand extreme temperatures and the many heavy-duty construction tasks for which this machine has been designed. Complete machine operating data are displayed on a high resolution monitor. A GSM/GPRS/GPS-modem allows for remote inquiry of machine data and error indications. To ensure clarity of the information on display, different levels of data are shown in enlarged lettering and symbols. Control and monitoring of the sensors are also handled by this high technology system. Error indications are automatically displayed on the monitor in clear text. The machine is equipped with electro-hydraulic continuous proportional control for all movements, which can be carried out simultaneously. Two joysticks are required for operation. Pedal control can be changed to hand control.

Options:

PDE® – process data recording
GSM/GPRS/GPS-modem



Hammer winch with free fall

Line pull (effektiv) ————— 104 kN
Rope diameter ————— 24 mm
Rope speed ————— 0-55 m/min

The winches are noted for compact, easily mounted design. Propulsion is via a maintenance-free planetary gearbox in oil bath. Load support by the hydraulic system; additional safety factor by a spring-loaded, multi-disc holding brake.



Pile winch with free fall

Line pull (effective) ————— 80 kN
Rope diameter ————— 20 mm
Rope speed ————— 0-55 m/min

The winches are noted for compact, easily mounted design. Propulsion is via a maintenance-free planetary gearbox in oil bath. Load support by the hydraulic system; additional safety factor by a spring-loaded, multi-disc holding brake.



Noise emission

Noise emissions correspond with 2000/14/EC directive.

Guaranteed sound pressure level L_{PA} in the cabin ————— ≤ 75.4 dB(A)
Guaranteed sound power level L_{WA} ————— ≤ 111 dB(A)
Vibration transmitted to the hand-arm system of the machine operator ————— < 2.5 m/s²
Vibration transmitted to the whole body of the machine operator ————— < 0.5 m/s²

Process data recording system - PDE® (additional equipment)

The Liebherr process data recording system PDE® constantly records the relevant process data during the working process.

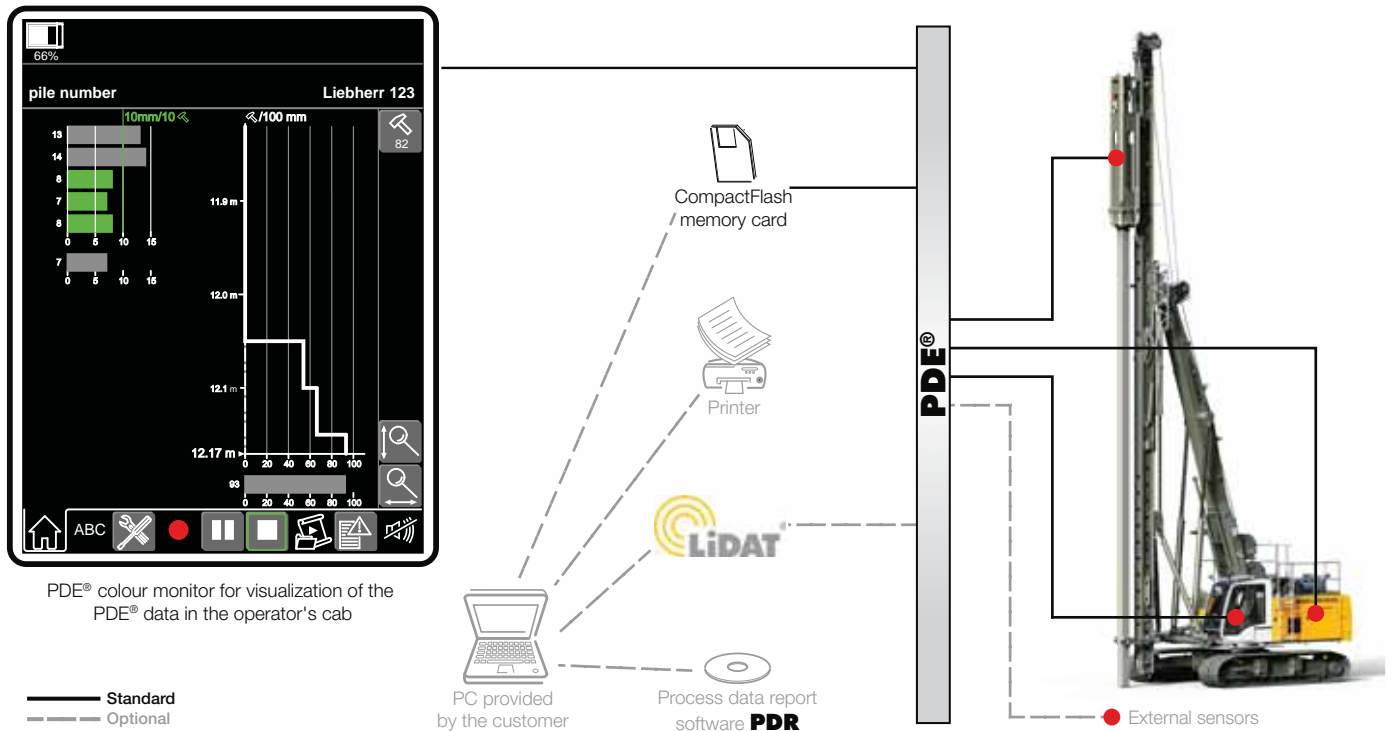

Depending on the application the recorded and processed data are displayed on the PDE® touchscreen in the operator's cab, e.g. in the form of an online cast-in-place pile.

At the same time the PDE® is operated using this touchscreen. The operator can enter various details (e.g. jobsite name, pile number, etc.) and start and stop recordings. A recording of every start-stop cycle carried out in the PDE® is established on a CompactFlash memory card.

The PDE® can be configured in a number of ways, e.g. for the connection of external sensors, for the generation of a simple protocol as graphic file and/or for a printout directly in the operator's cab.

Process data reporting - PDR (additional equipment)

Comprehensive data evaluation and generation of reports on a PC is possible using the software PDR.

Recordings management - The recordings generated by the PDE® system can be imported and managed in PDR. The data can be imported directly from the CompactFlash card or via the Liebherr telematics system LiDAT. Certain recordings, e.g. for a particular day or jobsite, can be found using filter functions.

Viewing data - The data in each record is displayed tabularly. Combining several recordings provides results, for example, regarding the total concrete consumption or the average depth. Furthermore, a diagram editor is available for quick analysis.

Generating reports - A vital element of PDR is the report generator, which allows for the generation of individual reports. These can be printed out directly or stored as pdf files. In the process the size, colour, line thickness or even the desired logo can be configured. Moreover, the reports can be displayed in different languages, e.g. in English and in the national language.

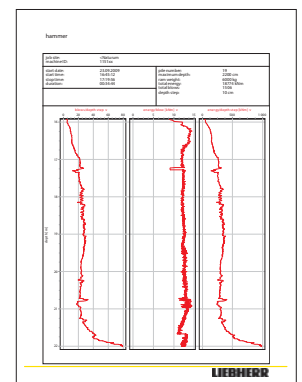

LRH 100 at work



LRH 100 at work



Liebherr-Werk Nenzing GmbH

Dr. Hans Liebherr Str. 1, 6710 Nenzing/Austria
Tel.: +43 50809 41-473, Fax: +43 50809 41-499
crawler.crane@liebherr.com, www.liebherr.com
facebook.com/LiebherrConstruction