CASES UPDATE A320 ATA 27

RTW 2023

LIEBHERR

Liebherr-Aerospace

Agenda

- Valve Block LVDT
- Rudder Servo Actuator Eye-end
- E-Rudder Servo Control

Valve Block LVDT

SCHEDULE AND COMMERCIAL

Liebherr SB: 787A-27-05 Since 24.03.2016.

MITIGATIONS

Low Temperature Test
High Temp Test

SOLUTIONS

LVDT PN: 9070A0008-03
since 24.03.2016.

IN-SERVICE OCCURRENCES

FLAP (SLAT) SYS 1 (2)
Fault with failure
message VALVE
BLOCK - VALVE SENSOR

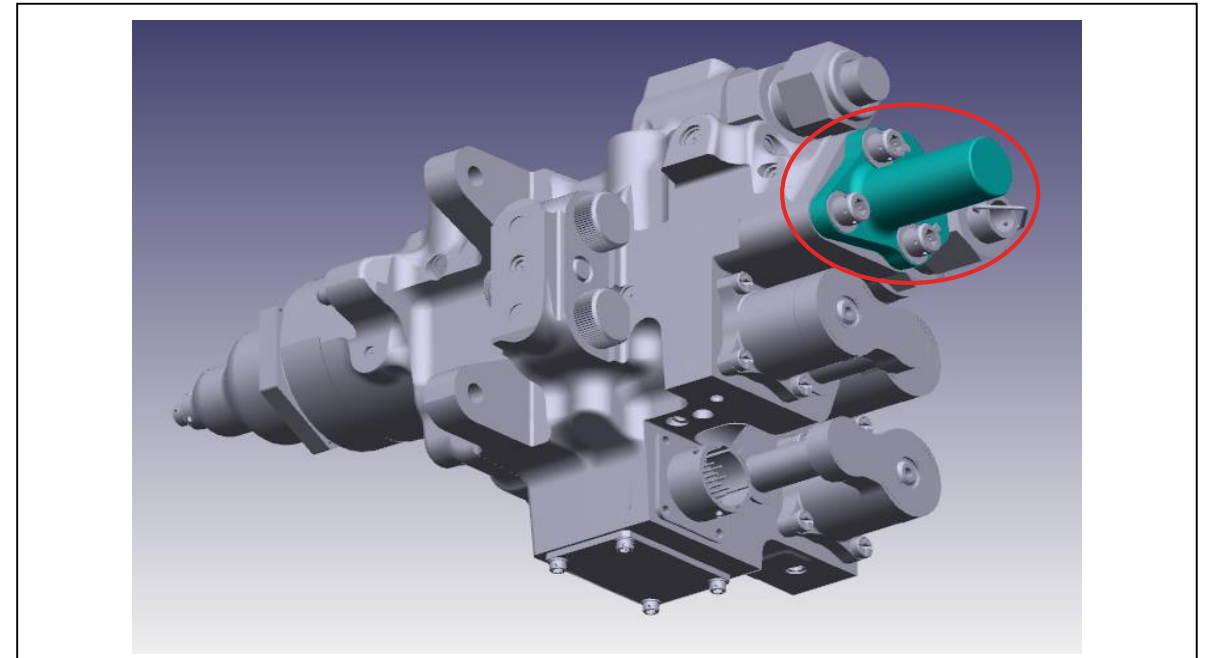

- New LVDT shows good reliability.
- No more removals of new LVDT 9070A0008-03

Rudder Servo Actuator Eye-end

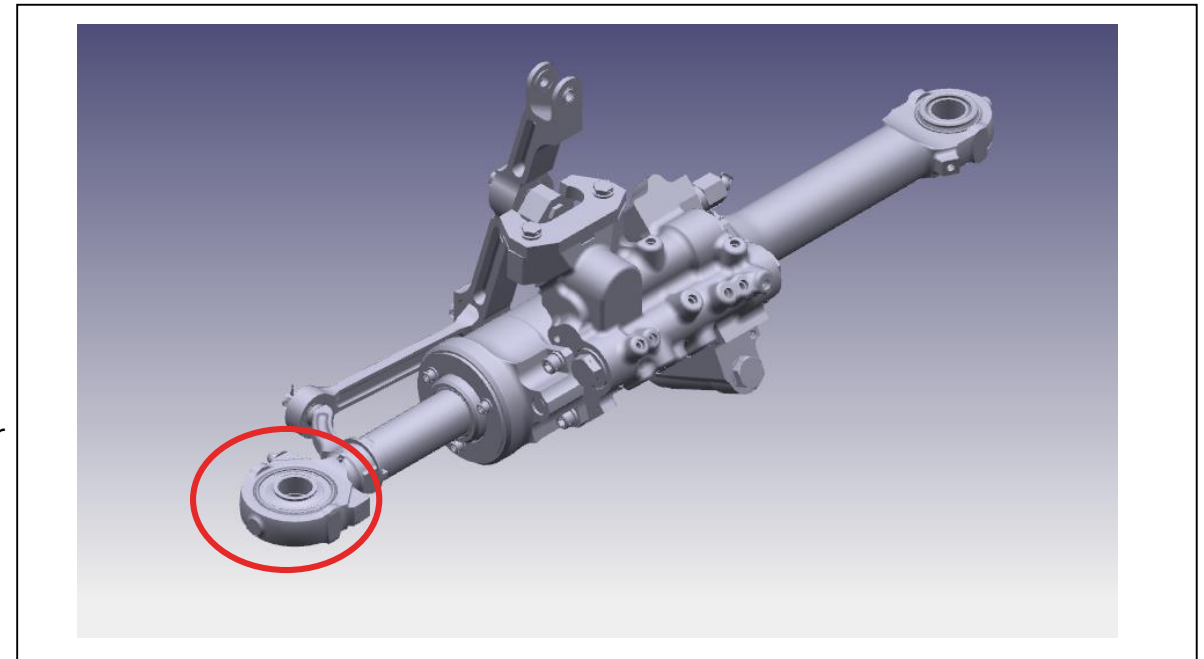
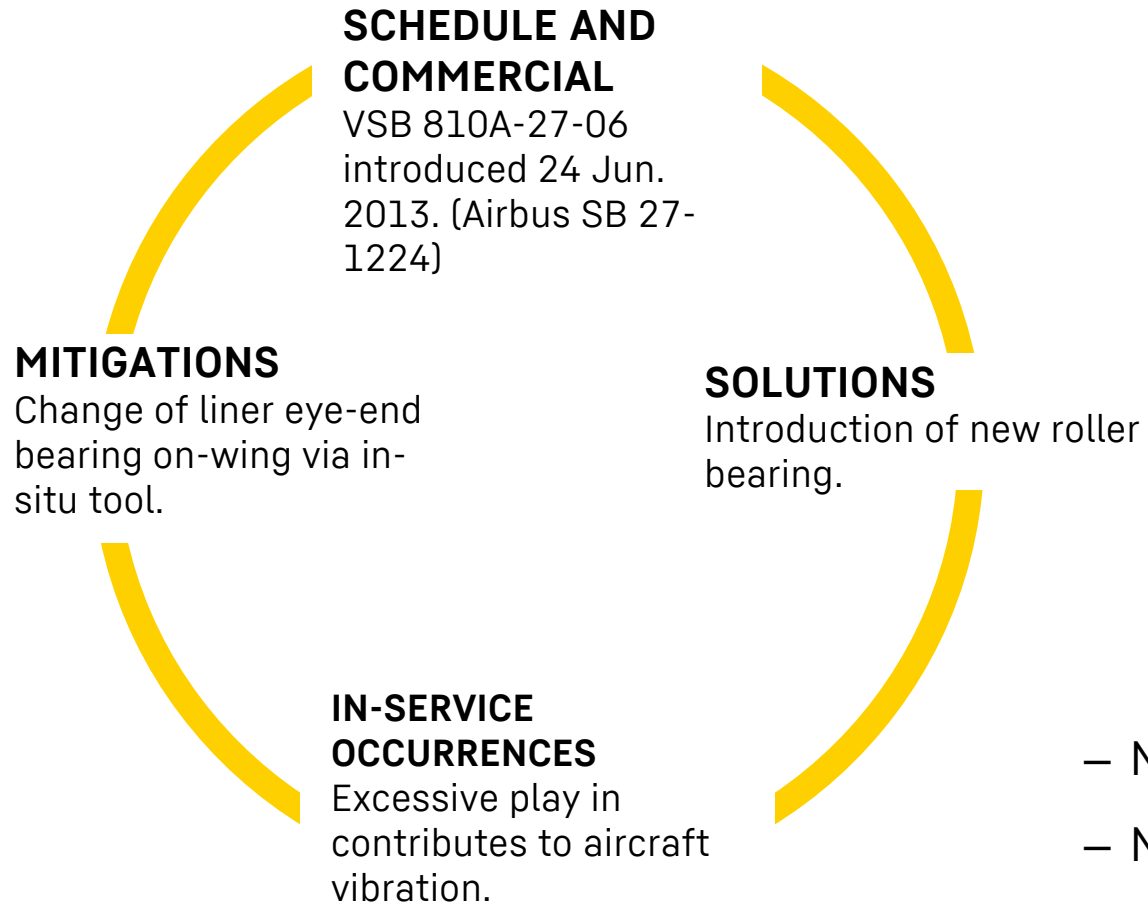

- New Eye-end shows good reliability
 - No new complaints
 - About 5,200 A/Cs flying with roller bearing as of end of 2021*
- *data from Airbus

E-Rudder Servo Control

E-Rudder Servo Control PN 812A0000-02 for future A320Neo E-Rudder system. Modification not possible from current build standard.

Component Name	Replacement Level
Rudder servo control	AMM level On AC
Rod End Assy	AMM level Off AC
EHSV	AMM level On AC
DPT	CMM level
Solenoid Valve	AMM level On AC
Bearing at Cylinder Housing Assy	CMM level
Jack Mounting point	CMM level
Filter	AMM level On AC

