

# Multiple Processing: Triple Lane Motor Control/Brake Electronic



## Key Characteristics/Function:

- Two dissimilar and independent lanes providing control and monitoring functions
- Supporting functions of ATA 27 (flight controls – high lift system)
- Supporting single controller dispatch (with one of two controllers inoperative)
- Use for safety critical functions
- Provides system control by electrical motor control and wing tip brake control
- Providing panel skew detection and actuator disconnect detection
- Providing system failure isolation
- High efficiency by PWM control of E-motor and brake power output
- Developed according to RTCA/DO-178C and RTCA/DO-254 (DAL A/C)
- Fully qualified according to RTCA/DO-160G
- Providing information via multiple discrete outputs to other systems
- Providing information via ARINC 429 buses to consuming systems
- Evaluating cockpit controls
- Evaluating multiple input information by other systems
- Automatic health check of system
- Supporting maintenance functions according to ARINC 604
- Supporting field loadable software according to ARINC 615
- Redundant control electronics power supply by 28 VDC and 115 VAC
- Power electronics power supply by 115 VAC

# Multiple Processing: Triple Lane Motor Control/Brake Electronic

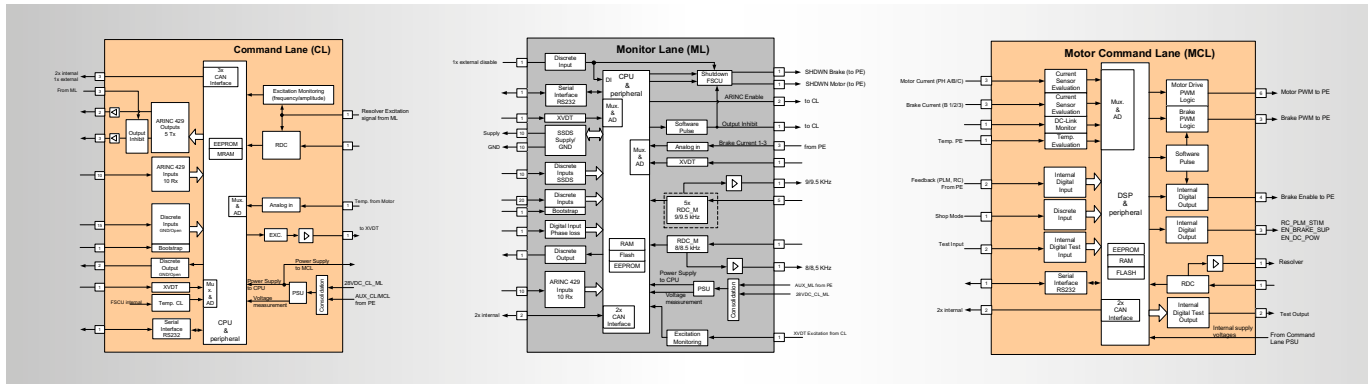

## Electrical Characteristics:

Dissimilar control/monitor architecture incl. motor power lane

- Processors
  - Motor power lane: digital signal processor
  - Control lane: micro-controller
  - Monitor lane: micro-controller
- Memory
  - RAM, Flash EPROM
  - EEPROM
- Data bus interface
  - ARINC 429
  - CAN, RS232
- Analog inputs
  - Motor/brake current
  - Internal/motor temperatures
  - Supply input voltages
  - DC link voltage
  - PSU voltages
- Resolver interface
- LVDT/RVDT interface
- Digital inputs:
  - Skew detection
  - Shop mode
  - Pin coding
  - Bootstrap mode
- Digital outputs: discrete outputs
- Power outputs: 1 x E-motor supply
- Brake supply

## Hardware Key Data:

- Supply voltage: 115 VAC/28 VDC
- Power dissipation: 42 W (control electronic)
- Output power: 2.1 kVA
- Housing: ARINC 404A/4 MCU
- Weight: 4.35 kg
- Typical MTBF: > 30,000 FH