

Grúa de celosía sobre cadenas

# LR 1300.1 SX

ES

LR 1006.02.07



# LIEBHERR

# Concepto y características

Gancho con contrapeso adicional

Pluma principal

Tirantes

Caballete

Superestructura

Contrapeso trasero

Chasis inferior

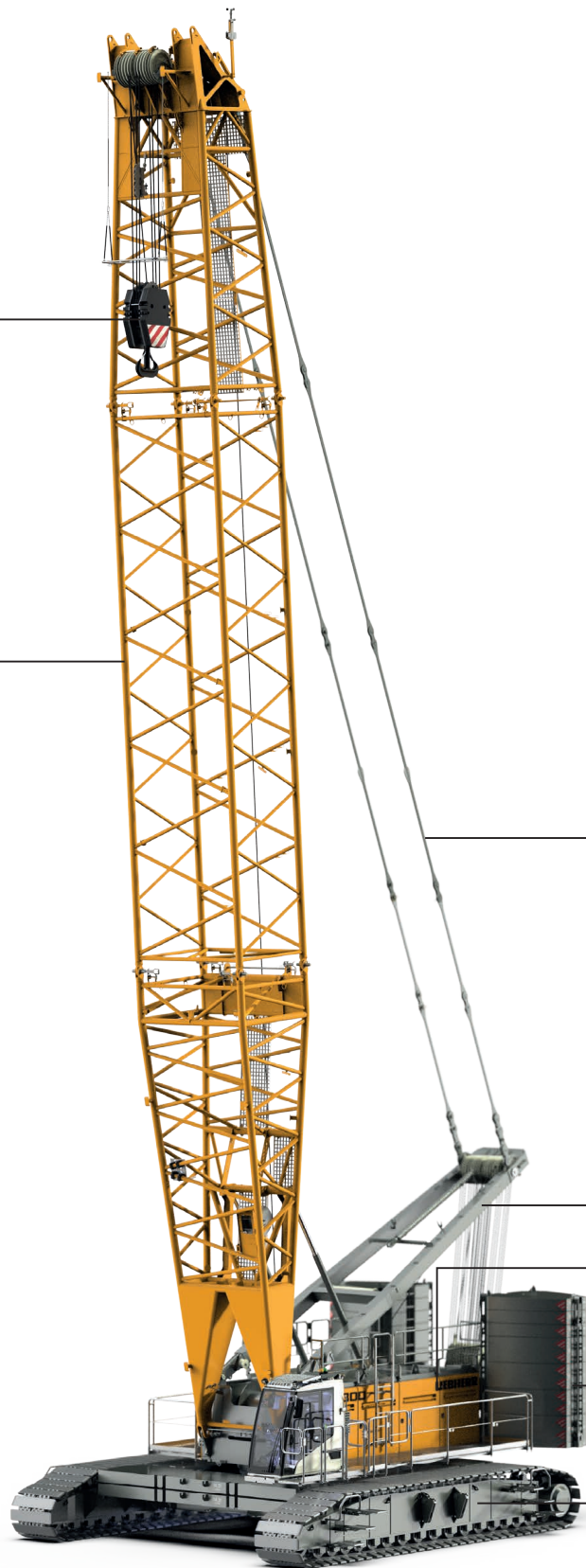

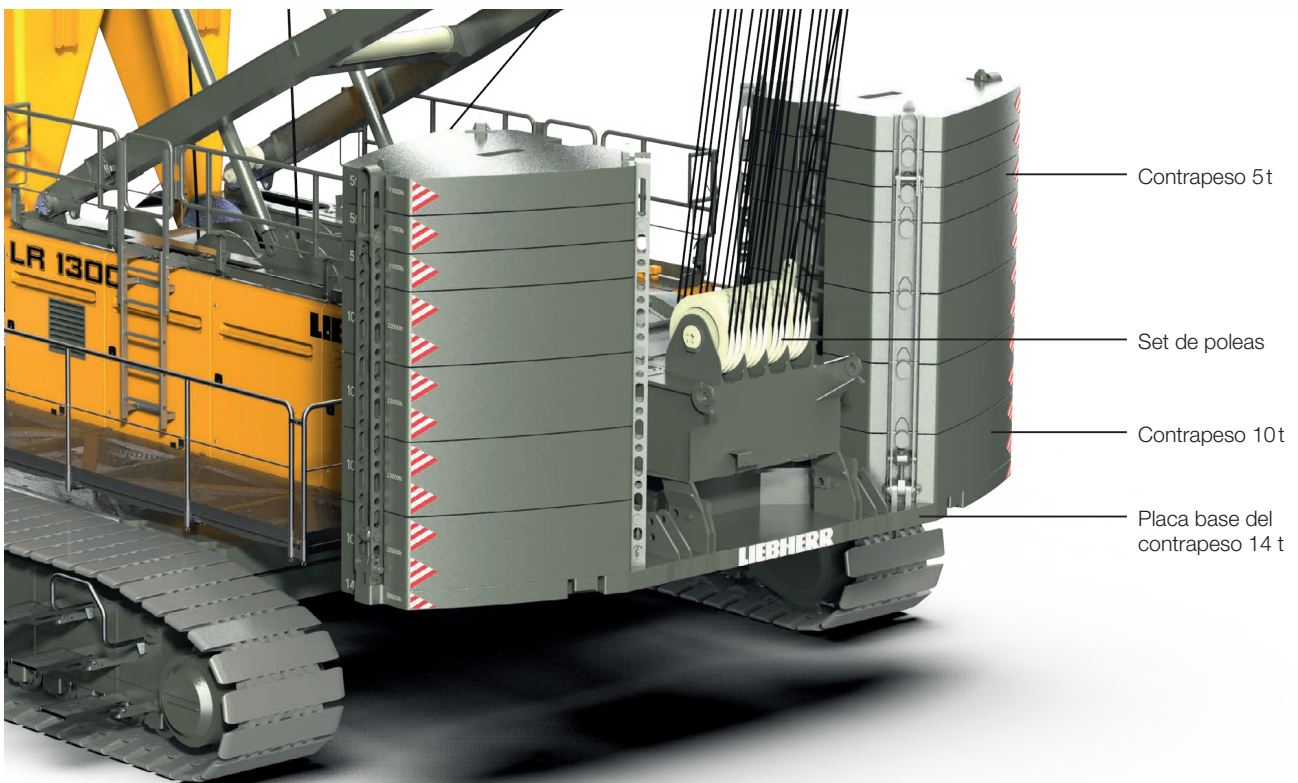
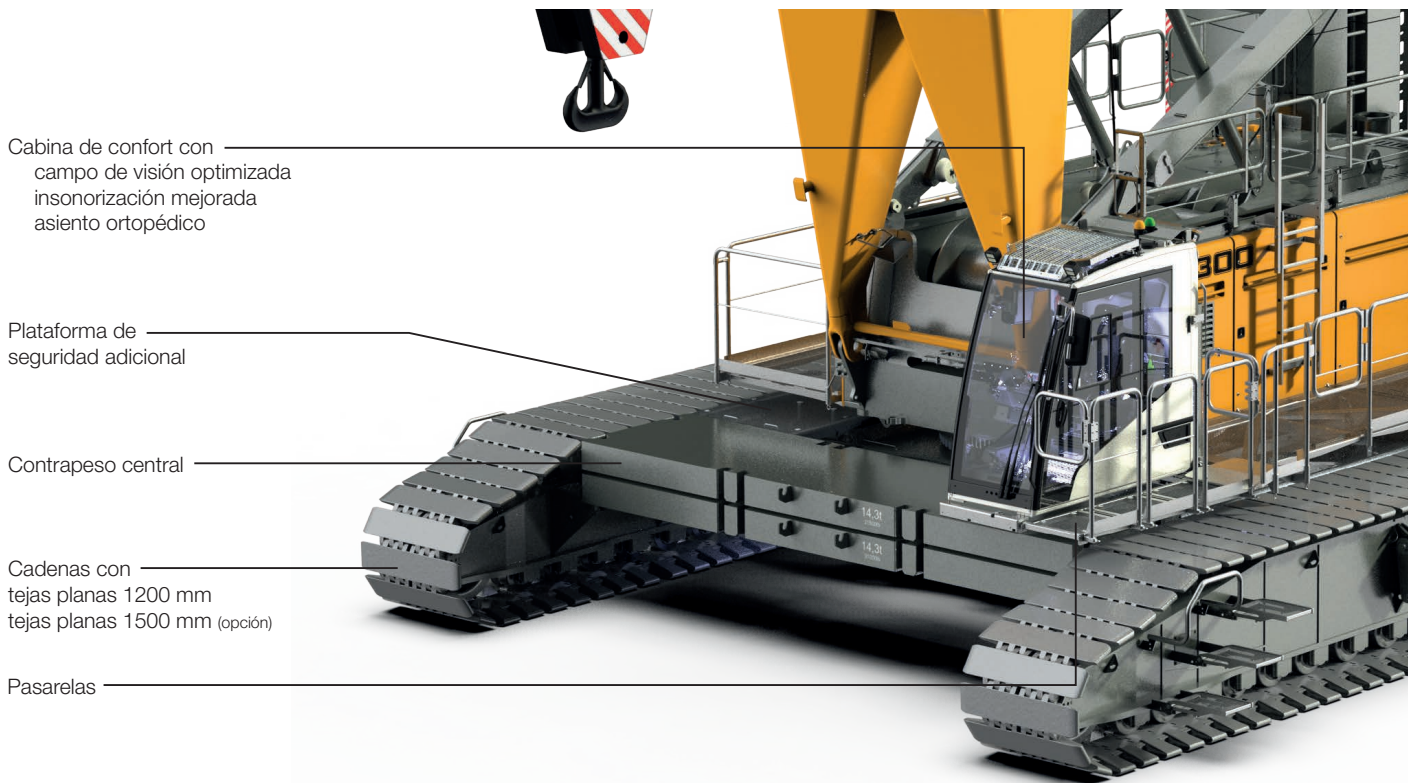

# Dimensiones

## Estándar

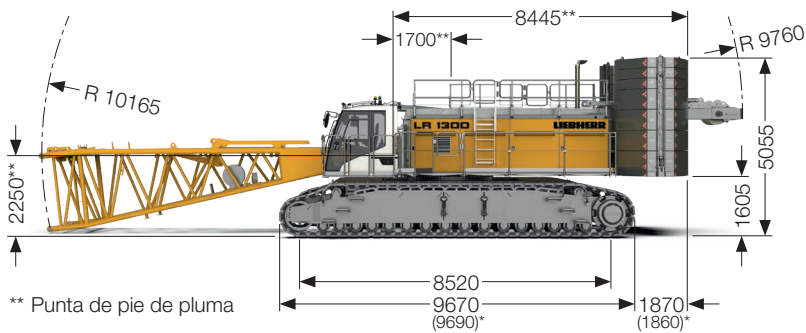

\*\* Punta de pie de pluma

\* Opción: Cadenas con tejas planas 1500 mm

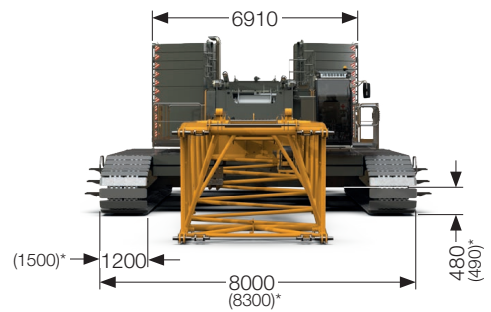
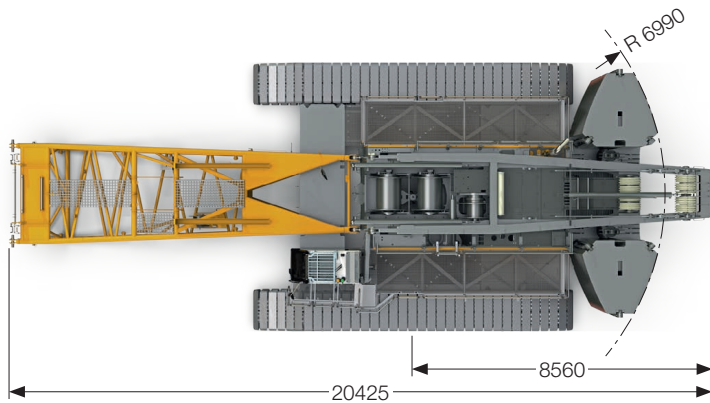

### Peso operacional

El peso operacional incluye la máquina base con cadenas, cabrestantes 1+2 (2x 150 kN) incluye 2 cables (2x 240 m) y una pluma principal de 20 m, que se compone de un caballete, pie de pluma (10 m), cabeza de pluma (7 m), tramo de pluma (3 m), contrapeso trasero de 124 t, contrapeso central de 57 t y un gancho de 300 t de capacidad.

Peso total aprox. 290 t

### Presión sobre el suelo

La presión de suelo actual se calcula acorde a la configuración y posición de la máquina en la cabina del operador. Usando la opción del software Crane Planner de Liebherr ya se puede calcular y visualizar la presión real del suelo en la fase de preparación.

### Equipo de trabajo

Pluma principal (No. 2821.xx)	20-92 m
Plumín fijo (No. 0906.21)	7 m
Plumín fijo (No. 1507.20)	8 m
Plumín fijo (No. 1008.xx)	11-26 m
Plumín fijo (No. 1713.xx)	14-35 m
Plumín abatible (No. 1916.xx)	20-95 m
Combinación máx. (pluma principal 65 m + plumín abatible 95 m)	160 m
Plumín abatible (No. 2316.xx)	20-113 m
Combinación máx. (pluma principal 56 m + plumín abatible 113 m)	169 m
Plumín auxiliar fijo para pluma principal (No. 2821.xx)	36 t
Plumín auxiliar fijo para plumín abatible (No. 1916.xx)	15 t
Plumín auxiliar fijo para plumín abatible (No. 2316.xx)	30/45 t

### Observaciones

- Las mencionadas capacidades de carga son válidas para trabajos de elevación (corresponden según clasificación de grúas ISO 4301-1, grupo de grúas A1).
- La grúa debe estar situada sobre un terreno horizontal y firme.
- Los pesos de los implementos de elevación (tales como cables de elevación, ganchos, cuñeros etc.) se tienen que deducir de de las tablas de carga.
- Equipos adicionales montados en la pluma (tales como pasarelas etc.) se tienen que deducir de los valores de carga.
- Se puede preseleccionar, en el software de LML, la velocidad máxima permitida del viento quedando así reflejada en la tabla de carga.
- El radio de trabajo se mide desde el centro de la corona.
- Las capacidades de carga están indicadas en toneladas y son válidas para 360 grados de giro.
- El cálculo de estabilidad bajo la carga está basado en ISO 4305 tabla 1+2+3, valor vuelco 4°.
- Las estructuras están calculadas según EN 13001-1; EN 13001-2.
- Los últimos dígitos de las dimensiones proporcionados están redondeados (0 y 5). Estos pueden diferir de las dimensiones reales.
- Los pesos pueden variar dependiendo de la configuración de la máquina, el llenado de los tanques y el espesor de acero usado en su construcción.
- Las cifras de este folleto pueden incluir opciones, que no están dentro del suministro estándar de entrega de la máquina.

Chasis inferior con ancho de vía ajustable – tejas planas 1200 mm (opción)

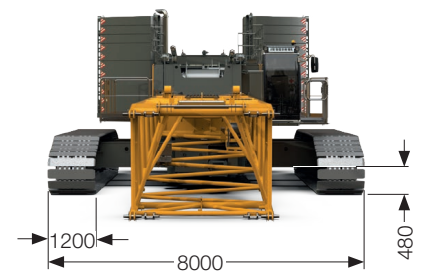
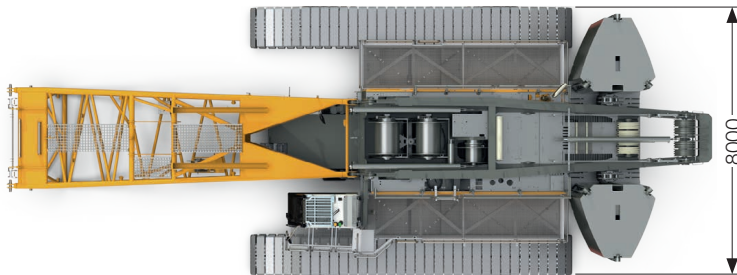
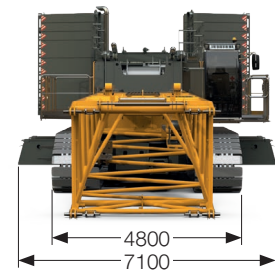
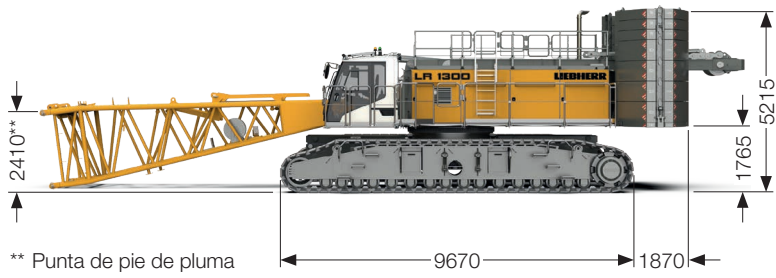

Chasis inferior con ancho de vía ajustable – tejas planas 1500 mm (opción)

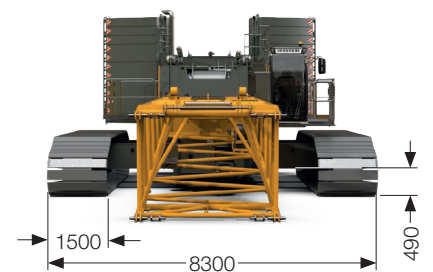
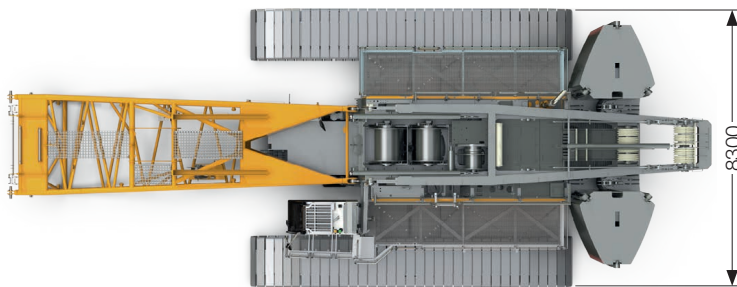
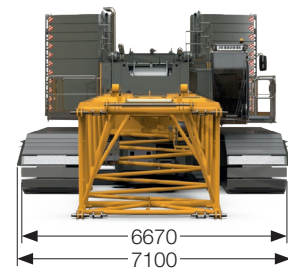
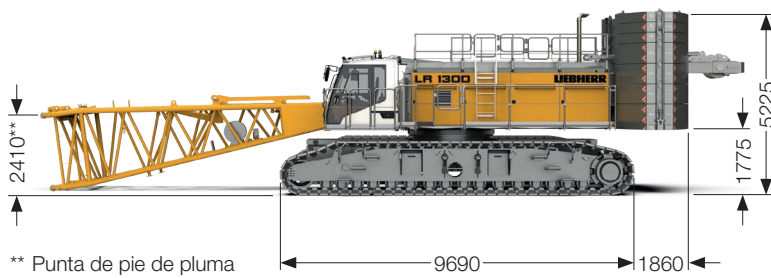

# Dimensiones y pesos de transporte

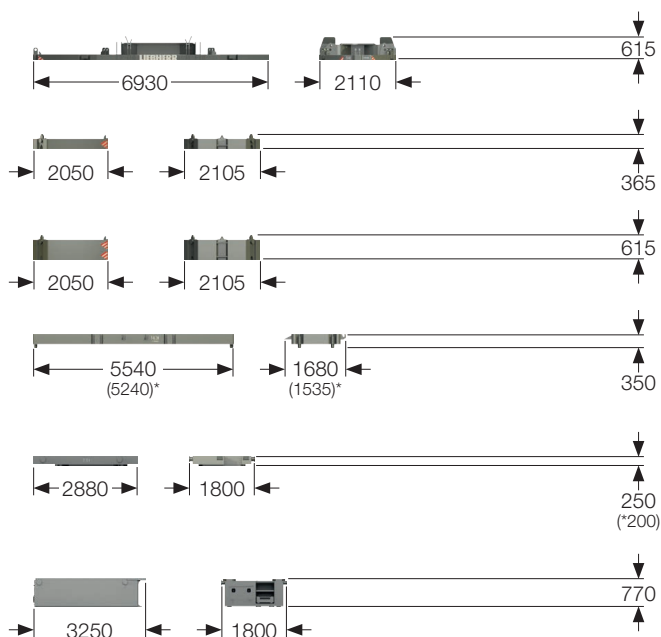
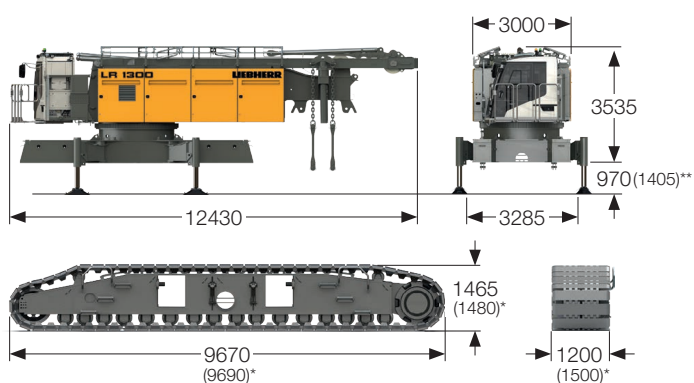
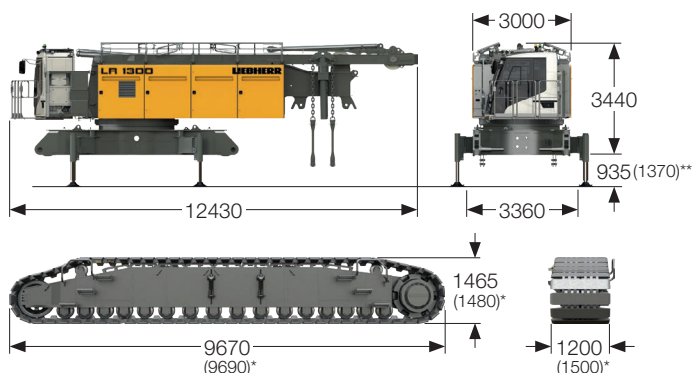

## Máquina base

### Máquina base

con caballete 1, cabrestantes 1+2 (2x 150 kN), sin pie de pluma, sin contrapeso trasero, sin contrapeso central y cadenas

Peso sin cables de elevación	46000 kg
Peso de los cables de elevación	4.2 kg/m

### Cadenas

	Estándar	Opción
Tejas planas	1200 mm	1500 mm
Peso	22350 kg	26200 kg

### Máquina base con ancho de vía ajustable (opción)

con caballete, cabrestantes 1+2 (2x 150 kN), sin pie de pluma, sin contrapeso trasero, sin contrapeso central y cadenas

Peso sin cables de elevación	46500 kg
Peso de los cables de elevación	4.2 kg/m

### Cadenas (opción ajuste vía estrecha)

	Estándar	Opción
Tejas planas	1200 mm	1500 mm
Peso	23000 kg	26850 kg

## Contrapeso

### Placa base del contrapeso sin sujeciones

Peso	14000 kg
------	----------

### Contrapeso

Peso	5000 kg
------	---------

### Contrapeso

Peso	10000 kg
------	----------

### Contrapeso central (para chasis inferior con ancho de vía fijo)

	Estándar	Opción*
Peso	14300 kg	13400 kg

### Contrapeso central (para chasis inferior con ancho de vía ajustable)

	Estándar	Opción*
Peso	7500 kg	5550 kg

### Contrapeso central (para chasis inferior con ancho de vía ajustable)

Peso	18800 kg
------	----------

\* Opción: Cadenas con tejas planas 1500 mm

\*\* Opción: Cilindros hidráulicos telescópicos

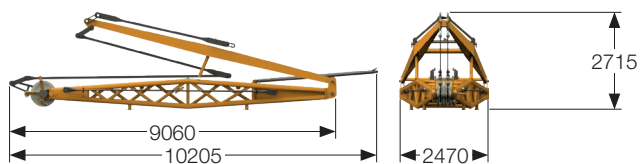
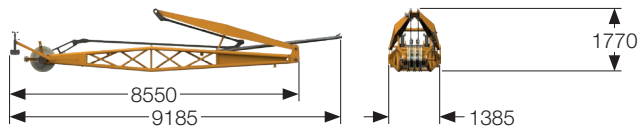
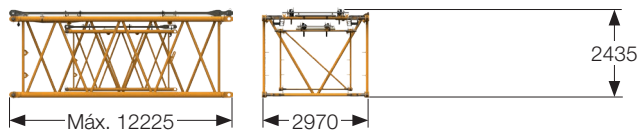
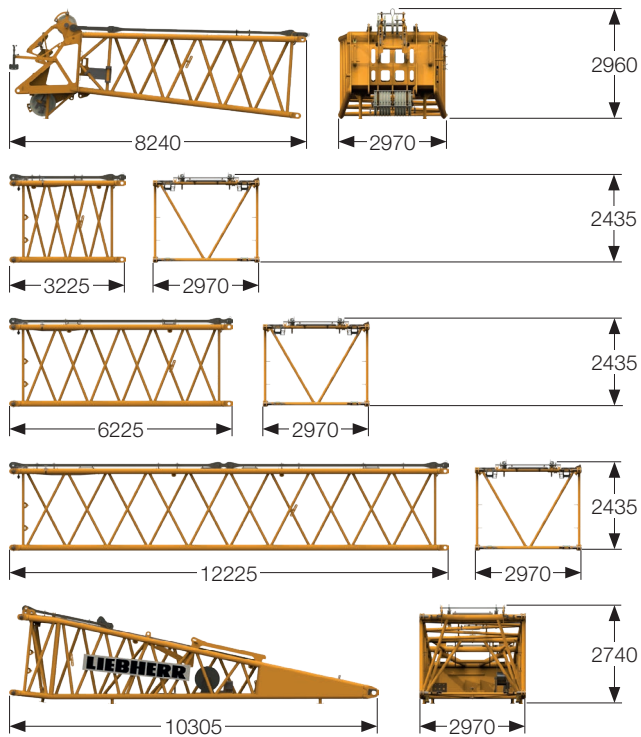

## Pluma principal (No. 2821.xx)

<b>Cabeza de pluma</b> (No. 2821.24)	<b>7 m</b>
Peso con HPT <sup>1)</sup>	5400 kg

<b>Tramo de pluma</b> (No. 2821.30)	<b>3 m</b>
Peso con HPT <sup>1)</sup>	1400 kg
Peso con HPT <sup>1)</sup> y NDL <sup>2)</sup>	1500 kg

<b>Tramo de pluma</b> (No. 2821.30)	<b>6 m</b>
Peso con HPT <sup>1)</sup>	2130 kg
Peso con HPT <sup>1)</sup> y NDL <sup>2)</sup>	2310 kg

<b>Tramo de pluma</b> (No. 2821.30)	<b>12 m</b>
Peso con HPT <sup>1)</sup>	3760 kg
Peso con HPT <sup>1)</sup> y NDL <sup>2)</sup>	4120 kg

<b>Pie de pluma</b> (No. 2821.30)	<b>10 m</b>
Peso con cabrestante incluye cables	7400 kg
Peso sin cabrestante	5700 kg

<sup>1)</sup> Tirantes de pluma

<sup>2)</sup> Tirantes de plumín

## Opción de transporte de pluma

<b>Opción de transporte</b> (No. 2821.xx/2316.xx)			
Tramos 3 m de pluma principal y de plumín			
Tramos 6 m de pluma principal y de plumín			
Tramos 12 m de pluma principal y de plumín			
	3/3 m	6/6 m	12/12 m
Peso incluye tirantes	2100 kg	3260 kg	5920 kg

## Plumín fijo (No. 0906.21)

<b>Plumín fijo</b> (No. 0906.21)	<b>7 m</b>
Peso incluye tirantes	2400 kg

## Plumín fijo (No. 1507.20)

<b>Plumín fijo</b> (No. 1507.20)	<b>8 m</b>
Peso incluye tirantes	3300 kg

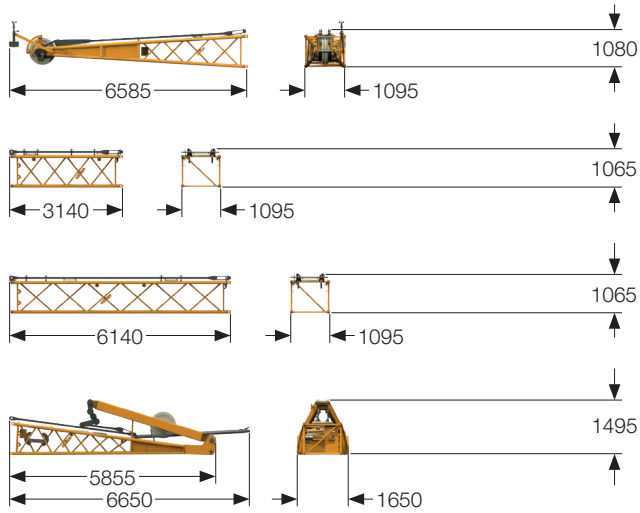

## Plumín fijo (No. 1008.xx)

**Cabeza de plumín fijo** (No. 1008.20) **5.5 m**

Peso incluye tirantes 920 kg

**Tramo de plumín** (No. 1008.17) **3 m**

Peso incluye tirantes 300 kg

**Tramo de plumín** (No. 1008.17) **6 m**

Peso incluye tirantes 630 kg

**Pie de plumín fijo con caballete** (No. 1008.20) **5.5 m**

Peso incluye tirantes 1950 kg

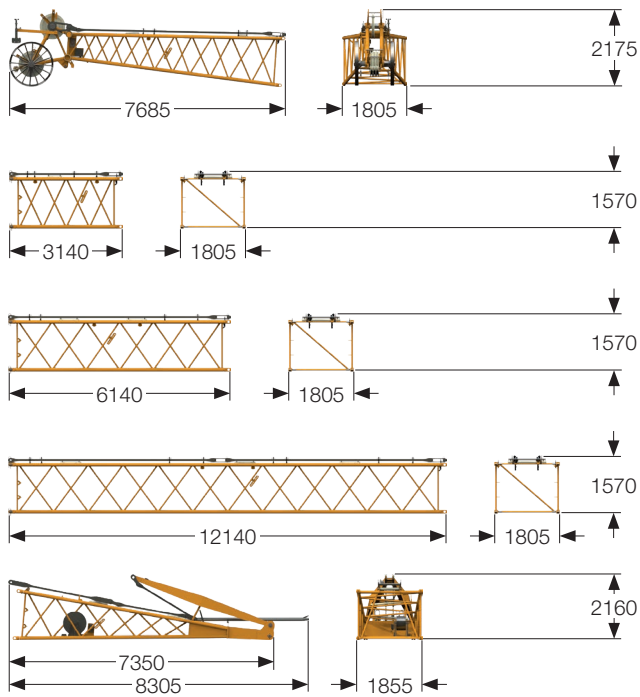

## Plumín fijo (No. 1713.xx)

**Cabeza de plumín fijo** (No. 1713.21) **7 m**

Peso incluye tirantes 1375 kg

**Tramo de plumín** (No. 1713.18) **3 m**

Peso incluye tirantes 420 kg

**Tramo de plumín** (No. 1713.18) **6 m**

Peso incluye tirantes 630 kg

**Tramo de plumín** (No. 1713.18) **12 m**

Peso incluye tirantes 1140 kg

**Pie de plumín fijo con caballete** (No. 1713.22) **7 m**

Peso incluye tirantes 4620 kg



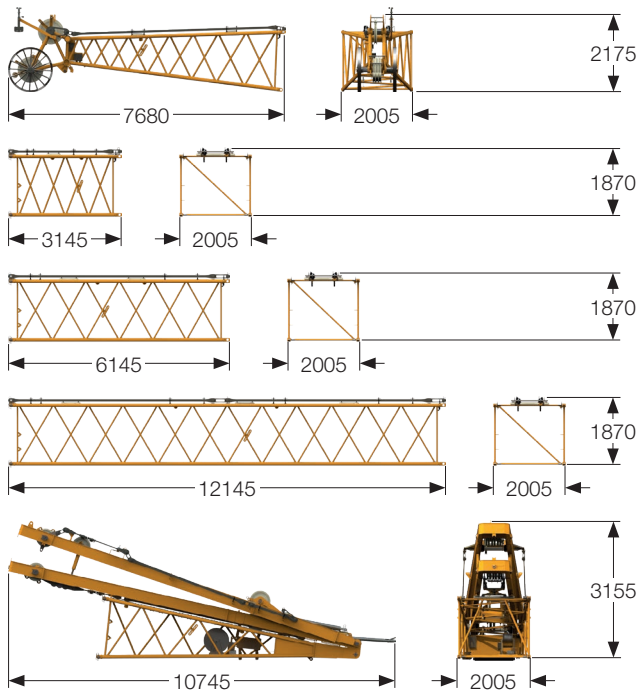

## Plumín abatible (No. 1916.xx)

**Cabeza de plumín abatible** (No. 1916.21) **7 m**

Peso incluye tirantes 1550 kg

**Tramo de plumín** (No. 1916.18) **3 m**

Peso incluye tirantes 475 kg

**Tramo de plumín** (No. 1916.18) **6 m**

Peso incluye tirantes 690 kg

**Tramo de plumín** (No. 1916.18) **12 m**

Peso incluye tirantes 1250 kg

**Pie de plumín abatible con caballetes 2 + 3** (No. 1916.22) **7 m**

Peso incluye tirantes 6300 kg

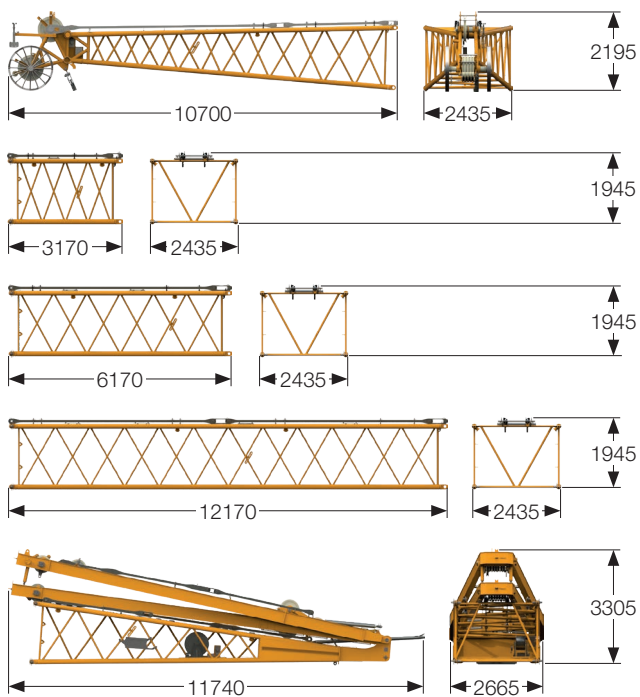

## Plumín abatible (No. 2316.xx)

**Cabeza de plumín abatible** (No. 2316.20) **10 m**

Peso incluye tirantes 2300 kg

**Tramo de plumín** (No. 2316.20) **3 m**

Peso incluye tirantes 600 kg

**Tramo de plumín** (No. 2316.20) **6 m**

Peso incluye tirantes 950 kg

**Tramo de plumín** (No. 2316.20) **12 m**

Peso incluye tirantes 1800 kg

**Pie de plumín abatible con caballetes 2 + 3** (No. 2316.22) **10 m**

Peso incluye tirantes 8060 kg

## Gancho con contrapeso adicional/ganchos simples

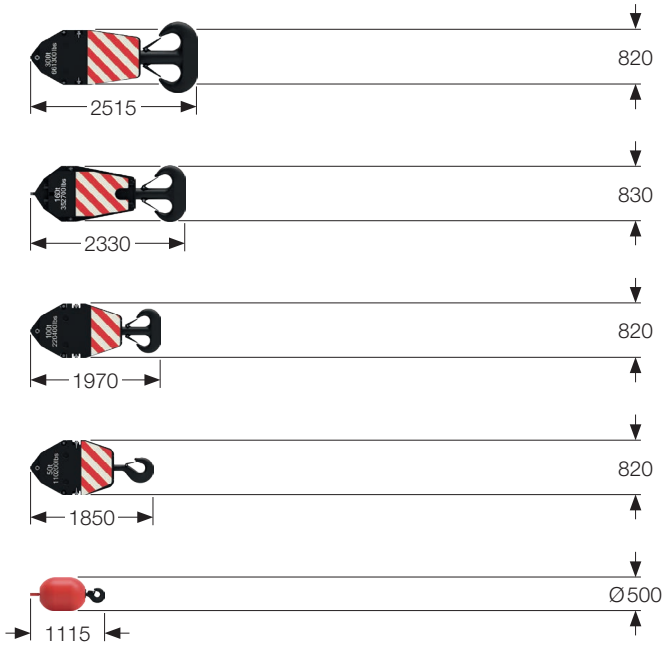

### Gancho 300 t – 11 poleas

Ancho	1220 mm
Peso	3200/5500 kg

### Gancho 160 t – 5 poleas

Ancho	925 mm
Peso	1600/2800/4000 kg

### Gancho 100 t – 3 poleas

Ancho	625 mm
Peso	1100/2050/3000 kg

### Gancho 50 t – 1 polea

Ancho	540 mm
Peso	800/1600/2400 kg

### Gancho simple 16 t

Peso	900 kg
------	--------

# Descripción técnica



## Motor diésel

Potencia controlada de acuerdo a la norma ISO 9249, 390 kW (530 caballos) a 1700 r.p.m.

Modelo ————— Liebherr D 946

Capacidad de tanque — 750 l capacidad con indicador continuo de nivel y de reserva

Variante 1: UE Stage V y US Tier 4f; variante 2: US Tier 4f; variante 3: UE Stage IIIA (Power Band H); variante 4: sin certificación



## Sistema hidráulico

Una bomba doble de desplazamiento axial se encarga de repartir aceite hidráulico a la pluma principal, el plumín abatible y las orugas, todo ello en circuito abierto. Los cabrestantes I y II y el reductor de giro funcionan en circuito cerrado. Todos los movimientos se pueden realizar de forma simultánea. Para evitar picos de presión hidráulica se incorpora una válvula de corte en la bomba. Todos los filtros están controlados electrónicamente. Existe la posibilidad de utilizar aceites sintéticos ecológicos, no perjudiciales para el medio ambiente. Además, se instala un modo de operación de emergencia.

Presión ————— máx. 350 bar

Tanque de hidráulico — 650 l



## Cabrestante de plumín abatible

Tiro del cable ————— máx. 138 kN

Diámetro del cable — 20 mm

Velocidad de 15° a 78° en 69 sec.



## Cabrestante de pluma

Tiro del cable ————— máx. 180 kN

Diámetro del cable — 24 mm

Velocidad de 15° a 86° en 127 sec.



## Mecanismo de traslación

Mecanismo de traslación con motor hidráulico de pistones axiales, frenos de discos múltiples accionados hidráulicamente, tensores hidráulicos de cadenas.

Tejas planas ————— 1200 mm (opción 1500 mm)

Velocidad de traslación - 0-1.23 km/h



## Mecanismo de giro

Corona de giro de rodamientos con dientes exteriores, accionado por un reductor con motor hidráulico de pistones axiales, frenos multi-disco accionados hidráulicamente, engranaje planetario y piñón. Dos posibilidades de modo de giro son posibles; tanto con control de velocidad giro, como giro libre. El freno de discos múltiples actúa automáticamente cuando no hay movimiento en la superestructura.

Velocidad de giro: 0 -1.8 r.p.m., regulable sin escalonamientos.



## Cabrestantes

Cabrestantes I y II estándares

Tiro (1a capa) ————— máx. 215 kN

Tiro (7a capa) ————— 150 kN

Diámetro del cable ————— 28 mm

Diámetro del tambor ————— 730 mm

Velocidad del cable ————— 0-113.5 m/min

Longitud de cable en 7 capas ————— 570 m

Los cabrestantes destacan por su diseño compacto y su facilidad de ensamblaje. Consisten de un engranaje planetario interno, bañado en aceite y de mantenimiento mínimo. La carga se sostiene por el sistema hidráulico, además de un factor de seguridad adicional, con un freno de discos múltiples (freno de parada). Para los cabrestantes se utiliza motores de control de alta presión y caudal variable. Este sistema dispone de sensores que automáticamente ajustan el caudal de aceite para alcanzar la máxima velocidad dependiendo de la carga suspendida.

Cabrestantes con caída libre (opción):

Tiro (1a capa) (modo grúa) ————— máx. 190 kN

Tiro (7a capa) (modo grúa) ————— 130 kN

Tiro (1a capa) (modo caída libre) ————— máx. 170 kN

Tiro (7a capa) (modo caída libre) ————— 118 kN

Diámetro del cable ————— 28 mm

Diámetro del tambor ————— 730 mm

Velocidad del cable ————— 0-130 m/min

Longitud de cable en 7 capas ————— 570 m

Los cabrestantes destacan por su diseño compacto y su facilidad de ensamblaje. En el cabrestante con caída libre se realiza la función de freno y de embrague solo con el freno de trabajo. Este freno es un freno de discos múltiples de diseño compacto, de bajo desgaste y sin necesidad de mantenimiento.



## Sistema de control electrónico

El núcleo de la grúa de celosía sobre cadenas es el sistema de control Litronic. Desarrollado y creado por Liebherr, este amplio sistema abarca todo el control y funciones de monitorización y esta diseñado para superar las condiciones ambientales más adversas y para trabajar en tareas de extrema dureza comunes en la construcción. Todos los datos relevantes de la operativa de la máquina, así como los mensajes de error y avisos, se visualizan en el idioma requerido en un monitor situado en la cabina. El control electro-hidráulico permite realizar varios movimientos de manera simultánea y precisa. Además, existe la posibilidad de configurar la velocidad del viento a través del LML resultando esto en una limitación de todos los movimientos de la máquina en función de esa pre-selección. Se incluye como estándar el modo elevación. Como opcional, se puede habilitar en el software, modos operacionales tales como cuchara, elevación de personal, cimentaciones según EN 16228 (p ej. vibrador y mástil) y pontona. Otra opción es la visualización de la presión sobre el suelo así como el centro de gravedad.



## Emisión de sonidos y vibración

Las emisiones de sonidos corresponden con la normativa 2000/14/EC.

Nivel de presión acústica de emisión  $L_{PA}$  en la cabina ————— 71.1 dB(A)

Nivel de potencia de sonido  $L_{WA}$  garantizado ————— 110 dB(A)

Vibración transmitida al tronco superior del operador ————— < 2.5 m/s<sup>2</sup>

Vibración transmitida a todo el cuerpo del operador ————— < 0.5 m/s<sup>2</sup>

# Configuraciones de pluma

Plumín fijo  
0906.21

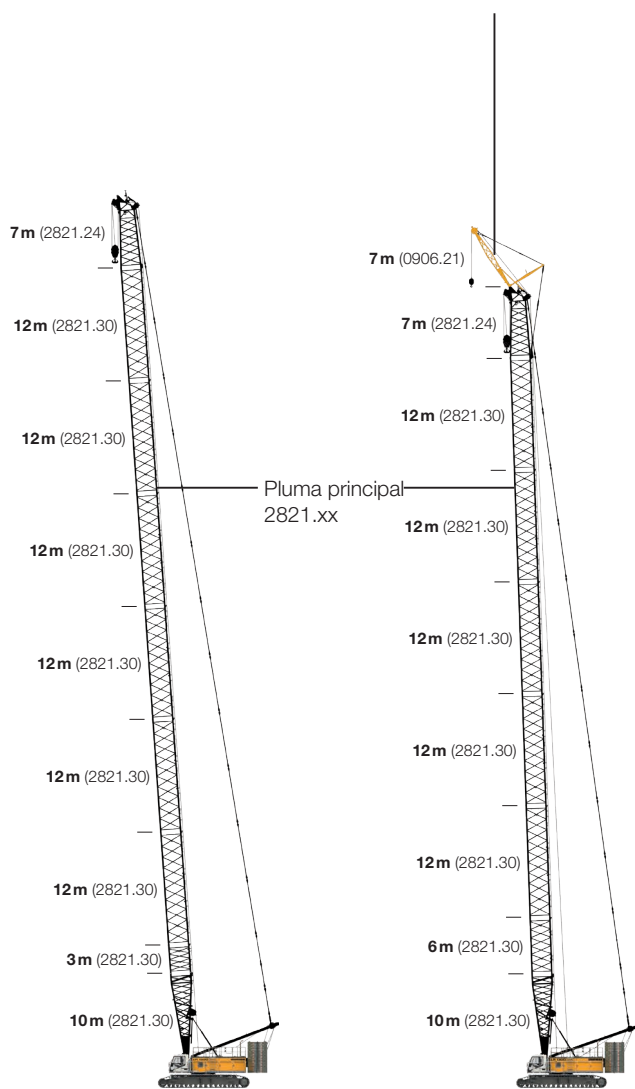

Pluma principal 92 m

Combinación máx.	90 m
Pluma principal	83 m
Plumín fijo	7 m

Plumín fijo  
1507.20

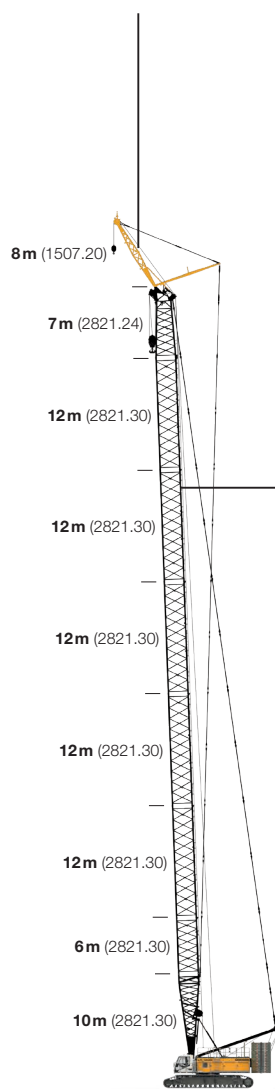

Combinación máx.	91 m
Pluma principal	83 m
Plumín fijo	8 m

Plumín fijo  
1008.xx

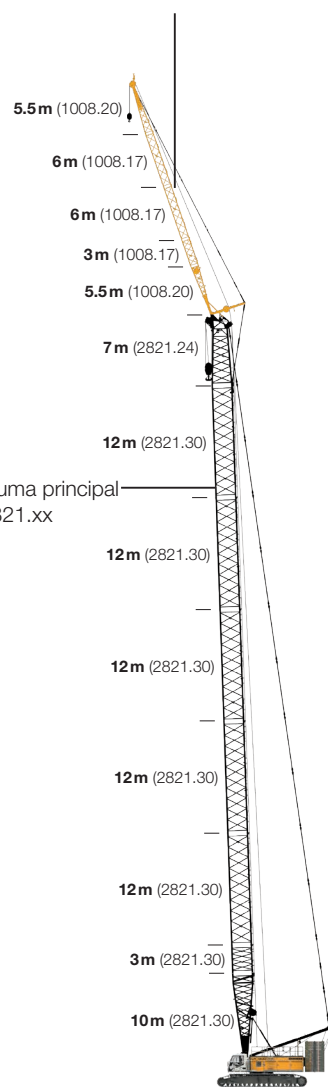

Combinación máx.	106 m
Pluma principal	80 m
Plumín fijo	26 m

Más información en la página 16.

Más información en la página 18.

Más información en la página 20.

Más información en la página 22.

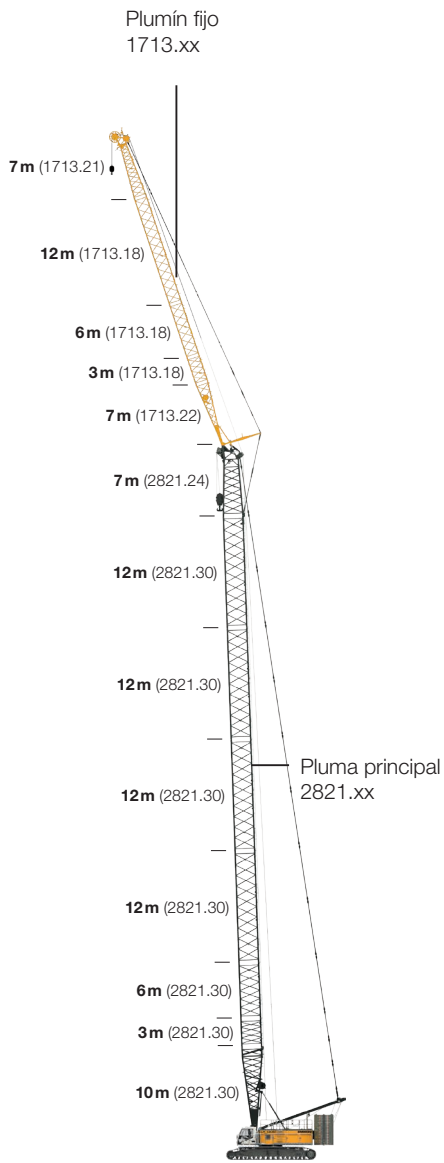

Combinación máx.	109 m
Pluma principal	74 m
Plumín fijo	35 m

Más información en la página 25.

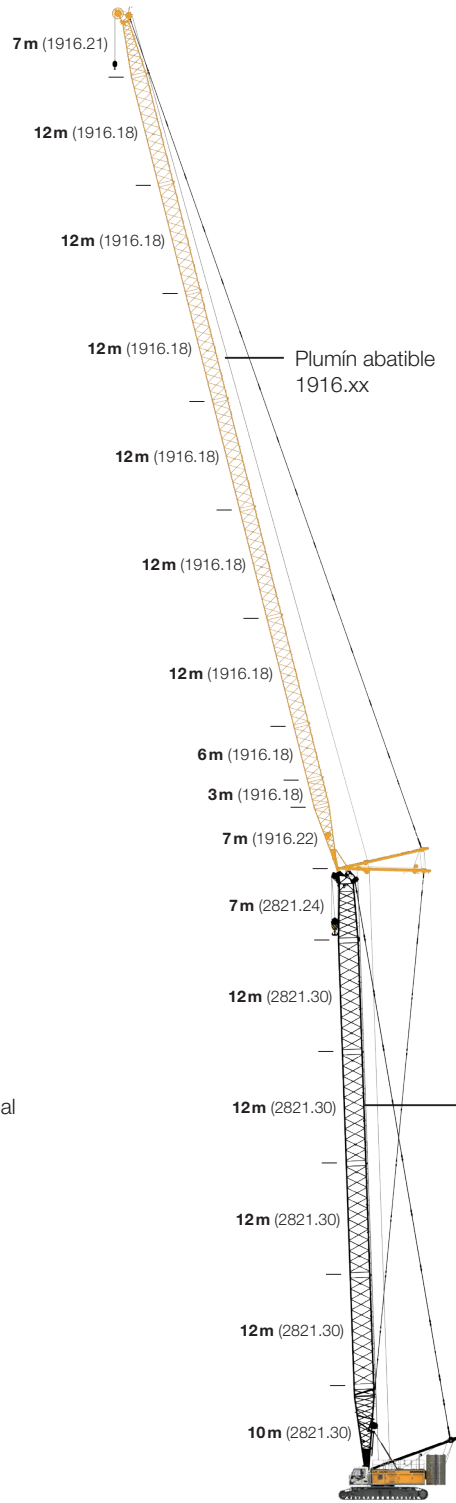

Combinación máx.	160 m
Pluma principal	65 m
Plumín abatible	95 m

Combinación máx.	115 m
Pluma principal	71 m
Plumín abatible	44 m

Más información en la página 28.

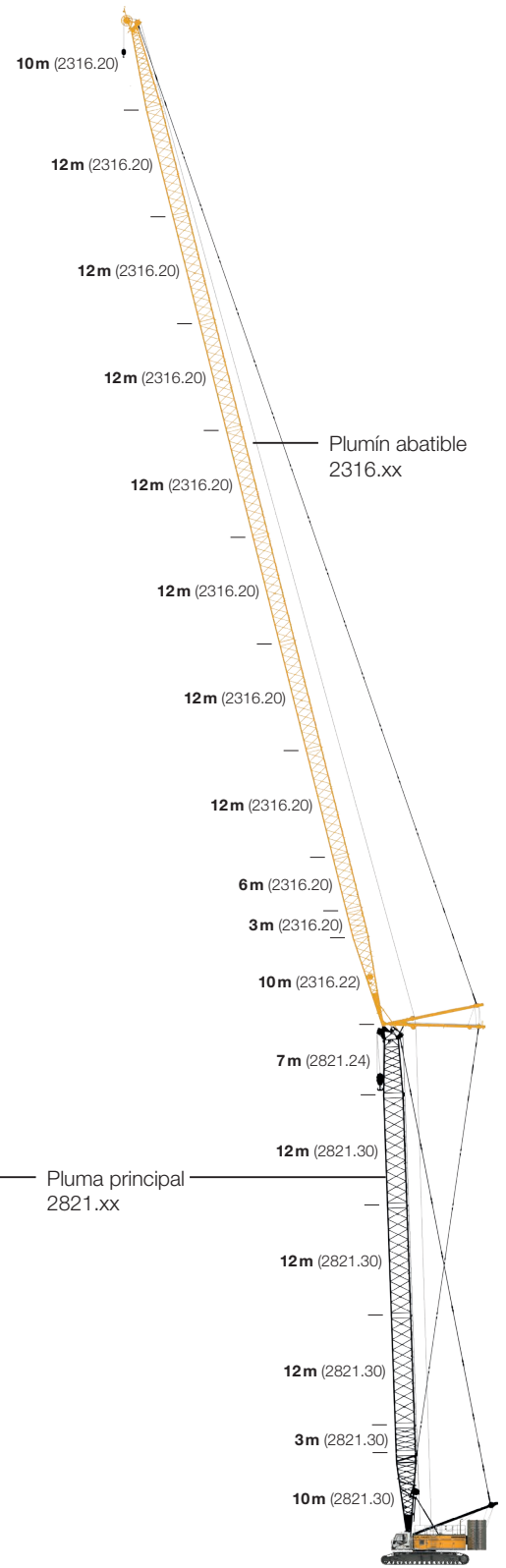

Combinación máx.	169 m
Pluma principal	56 m
Plumín abatible	113 m

Combinación máx.	106 m
Pluma principal	68 m
Plumín abatible	38 m

Más información en la página 32.

# Sistema de auto-montaje de la serie de grúas sobre cadenas

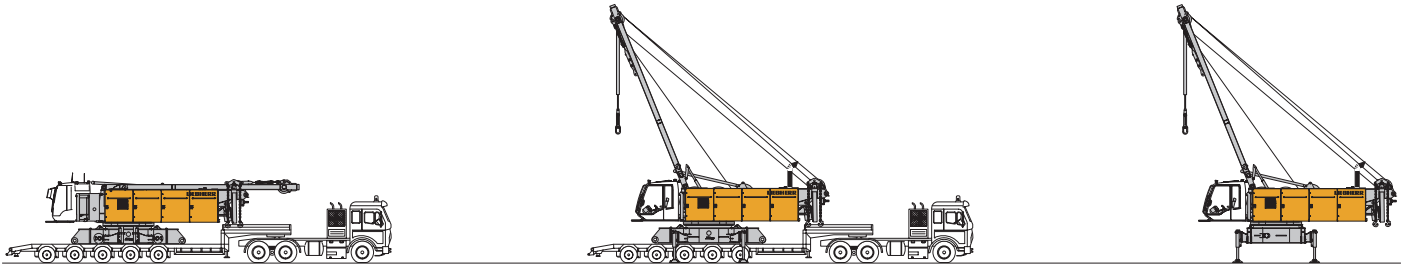

Descarga de la máquina base

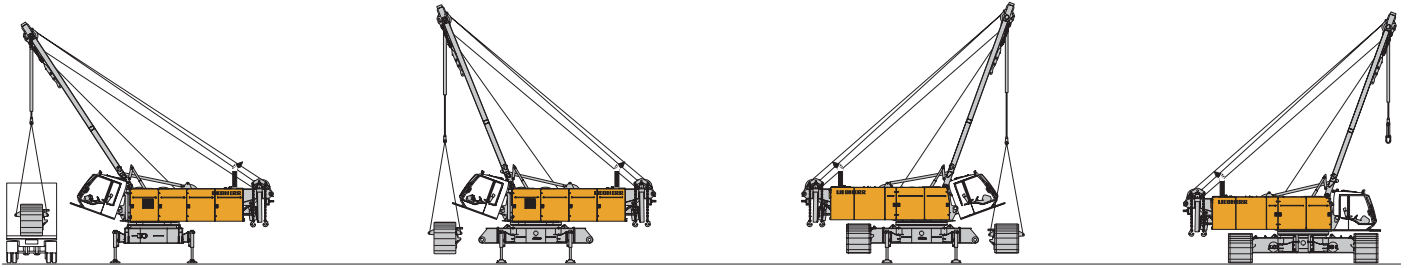

Descarga y montaje de las cadenas

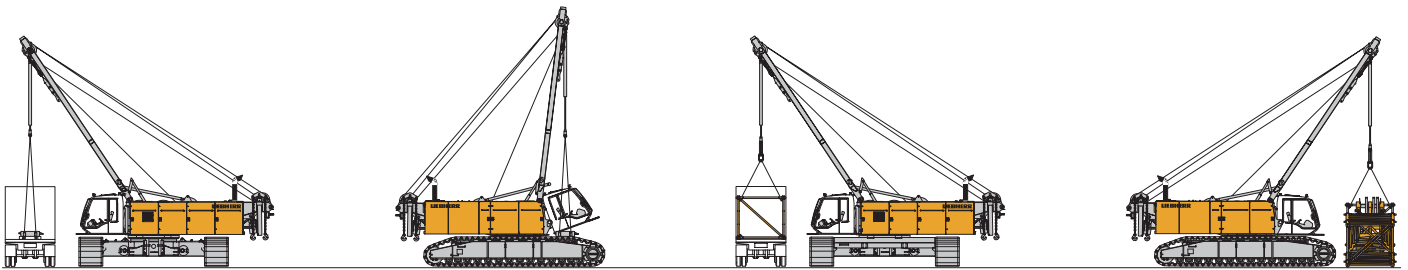

Descarga y montaje del contrapeso central

Descarga y montaje de la pluma

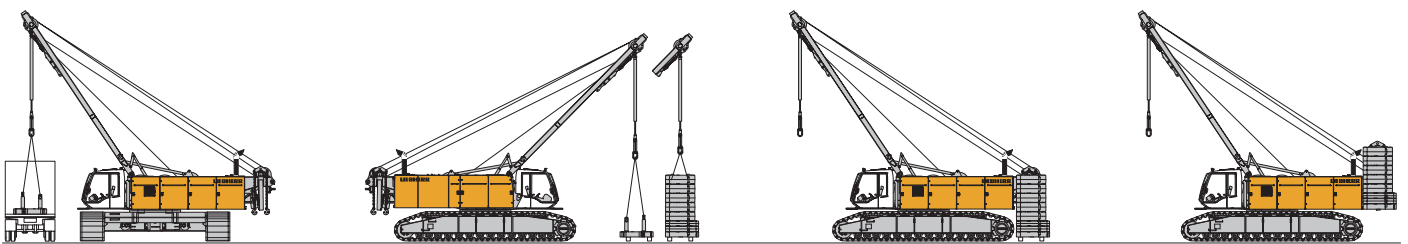

Descarga y montaje del contrapeso

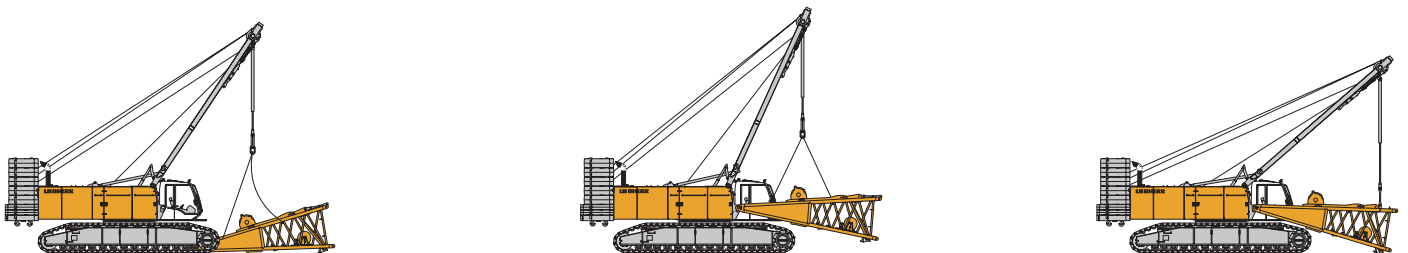

Descarga y montaje del pie de pluma

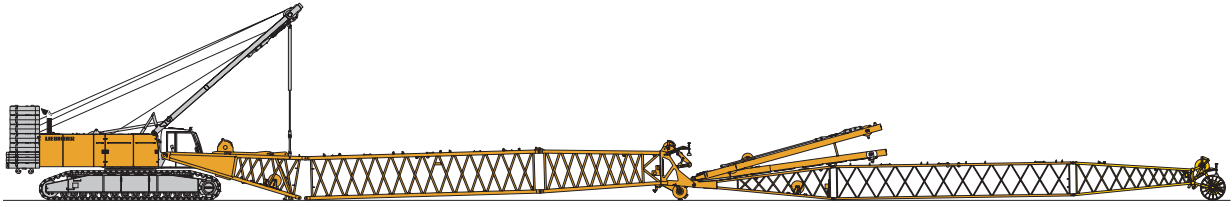

Montaje de la pluma

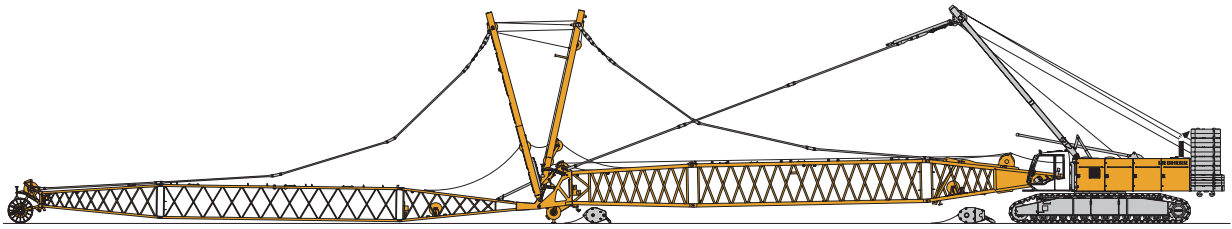

Montaje de los cables de elevación de la pluma principal y del plumín abatible

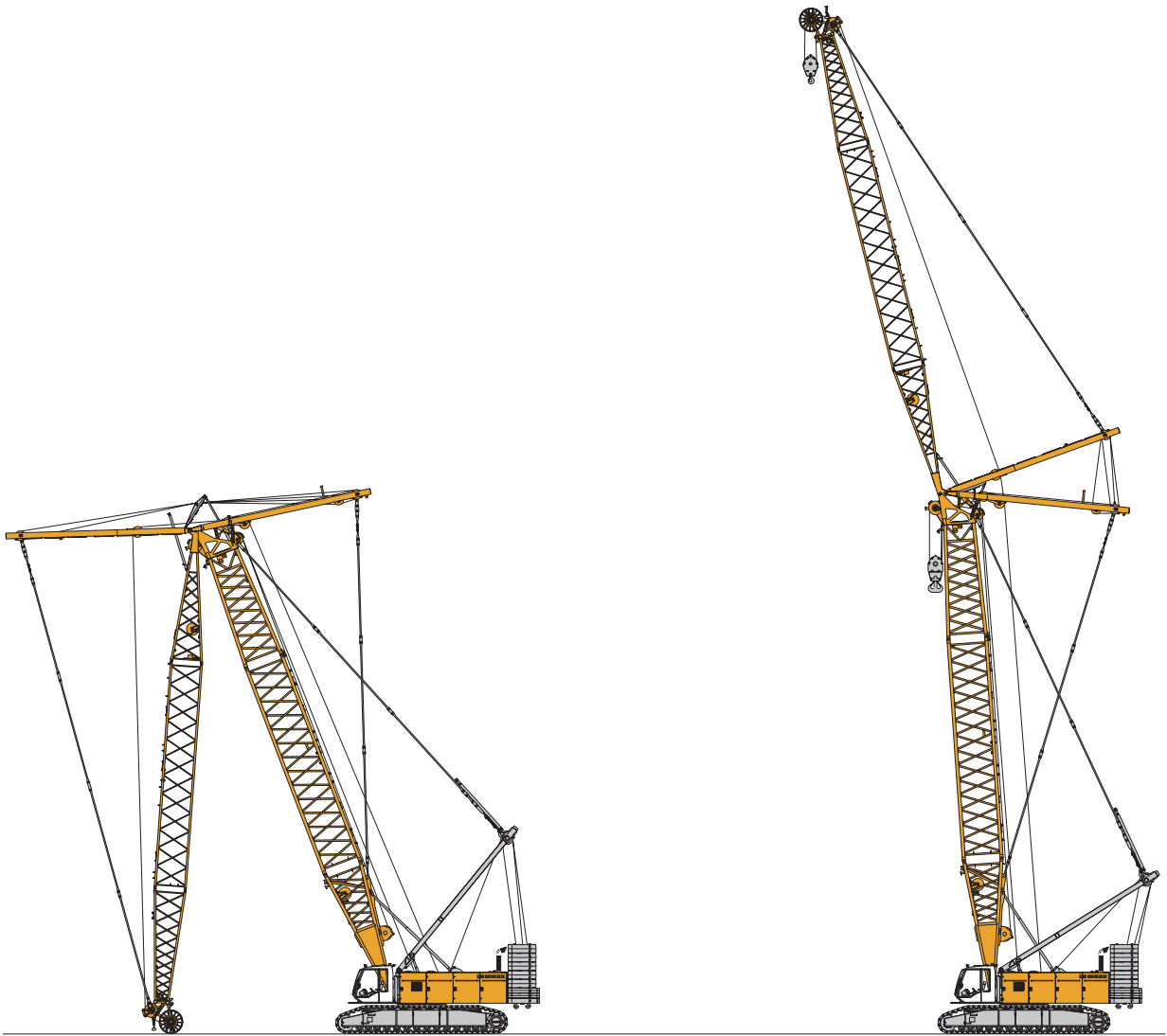

Elevación de la pluma principal y del plumín abatible

# Pluma principal (No. 2821.xx)

Pluma principal 86-15°, 20-92 m

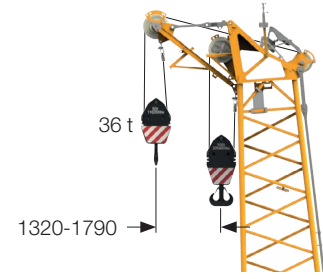
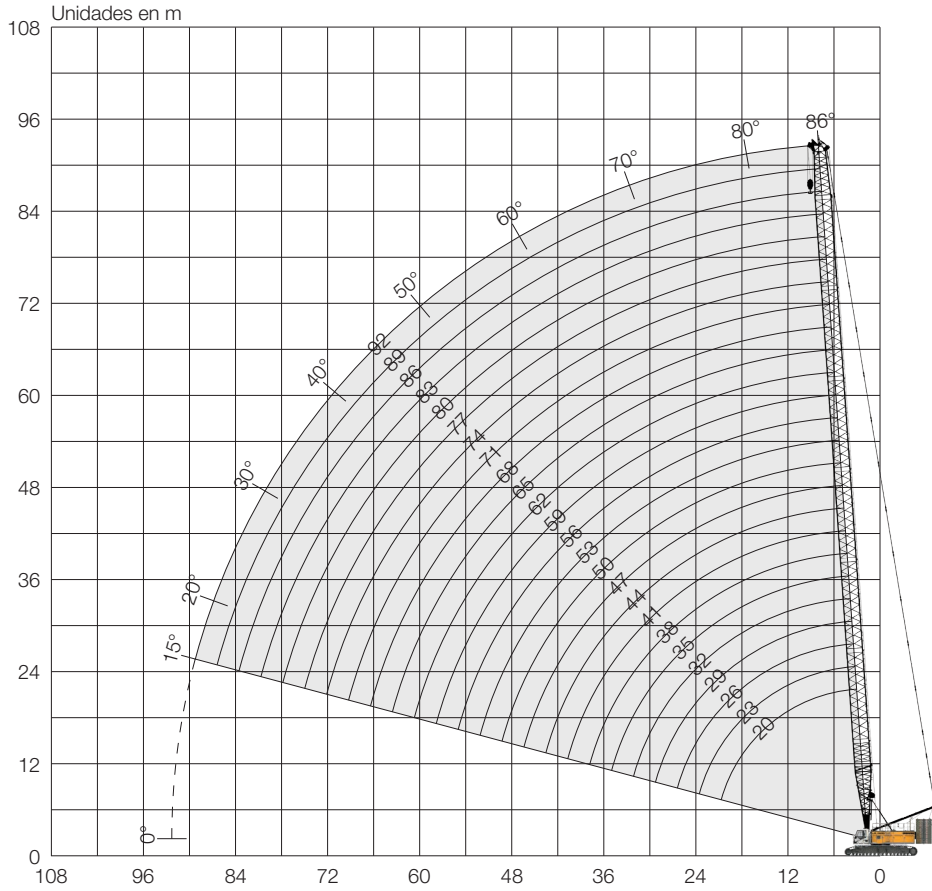

**Plumín auxiliar fijo 36 t** (opción)  
 La carga máx. del plumín auxiliar es de 36 t. Este plumín tiene su propia tabla de carga y requiere su correcta selección en el programa del limitador de carga en la cabina.

Pluma principal 92 m

## Configuración de pluma principal (No. 2821.xx)

	Longitud		Número de tramos de pluma principal																							
	20	23	26	29	32	35	38	41	44	47	50	53	56	59	62	65	68	71	74	77	80	83	86	89	92	
Pie de pluma	10 m	1	1	1	1	1	1	1	1	1	1	1	1	1	1	1	1	1	1	1	1	1	1	1	1	1
Tramo pluma	3 m	1		1		1		1		1		1		1		1		1		1		1		1		1
Tramo pluma	6 m		1	1		1	1		1	1		1	1		1	1		1	1		1	1		1	1	
Tramo pluma	12 m				1	1	1	1	2	2	2	2	3	3	3	3	4	4	4	4	5	5	5	5	6	6
Cabeza de pluma	7 m	1	1	1	1	1	1	1	1	1	1	1	1	1	1	1	1	1	1	1	1	1	1	1	1	1
<b>Longitud de pluma (m)</b>		<b>20</b>	<b>23</b>	<b>26</b>	<b>29</b>	<b>32</b>	<b>35</b>	<b>38</b>	<b>41</b>	<b>44</b>	<b>47</b>	<b>50</b>	<b>53</b>	<b>56</b>	<b>59</b>	<b>62</b>	<b>65</b>	<b>68</b>	<b>71</b>	<b>74</b>	<b>77</b>	<b>80</b>	<b>83</b>	<b>86</b>	<b>89</b>	<b>92</b>
Plumín auxiliar fijo aplicable		✓	✓	✓	✓	✓	✓	✓	✓	✓	✓	✓	✓	✓	✓	✓	✓	✓	✓	✓	✓	✓	✓	✓	✓	✓



Tabla de cargas para pluma principal (No. 2821.xx)

**Tabla de cargas con contrapeso trasero 104 t y contrapeso central 57 t**

Radio	Longitud de pluma (m)														Radio
	20	23	26	32	38	44	50	56	62	68	74	80	83	86	
[m]	[t]	[t]	[t]	[t]	[t]	[t]	[t]	[t]	[t]	[t]	[t]	[t]	[t]	[t]	[m]
4.3	300.5														4.3
5	300.5	296.3	299.6												5
6	262.9	260.0	256.1	245.5	236.5	213.4									6
7	225.5	225.3	222.0	215.8	206.9	198.3	189.3	169.3							7
8	195.9	195.7	195.2	191.1	184.6	178.4	168.6	161.3	151.1	135.3					8
9	172.9	172.8	172.2	171.8	166.0	160.2	152.7	145.0	137.8	131.1	118.7	103.1	95.6	88.9	9
12	126.8	126.7	126.2	125.8	122.6	117.3	112.1	107.4	102.8	98.5	94.4	90.5	87.5	83.3	12
14	107.0	106.9	106.5	106.1	102.8	98.7	94.7	91.0	87.3	83.9	80.5	77.4	75.8	74.3	14
16	89.2	89.3	89.2	89.1	88.1	84.8	81.5	78.5	75.5	72.6	69.8	67.1	65.8	64.5	16
20	65.2	65.5	65.4	65.3	64.8	64.5	63.1	60.8	58.5	56.4	54.2	52.2	51.1	50.1	20
24		50.8	50.8	50.8	50.3	49.9	49.3	48.8	47.1	45.3	43.5	41.8	40.9	40.0	24
26			45.3	45.4	44.9	44.5	43.9	43.4	42.6	41.0	39.3	37.7	36.9	36.0	26
32				33.7	33.4	33.0	32.4	31.8	31.2	30.6	29.5	28.2	27.5	26.7	32
38					25.7	25.4	24.8	24.3	23.6	23.0	22.3	21.4	20.8	20.1	38
42						21.6	21.0	20.5	19.8	19.2	18.5	17.9	17.4	16.7	42
50							15.3	15.0	14.3	13.7	13.0	12.4	12.0	11.6	50
55								12.3	11.7	11.1	10.4	9.7	9.4	9.0	55
60									9.4	8.9	8.2	7.5	7.2	6.8	60
65										7.0	6.3	5.7	5.4	5.0	65
70											4.7	4.1	3.7	3.2	70
75												2.5	2.1		75

**Tabla de cargas con contrapeso trasero 124 t y contrapeso central 57 t**

Radio	Longitud de pluma (m)															Radio	
	20	23	26	32	38	44	50	56	62	68	74	80	83	86	89		92
[m]	[t]	[t]	[t]	[t]	[t]	[t]	[t]	[t]	[t]	[t]	[t]	[t]	[t]	[t]	[t]	[t]	[m]
6.4							189.3										6.4
7							189.3	169.3									7
8					184.6	178.4	168.6	161.3	151.1	135.3							8
9					166.0	160.2	154.1	146.1	138.5	131.7	118.7	103.1	95.6	88.9			9
10			161.2	156.5	152.3	145.7	139.9	134.5	127.6	120.2	111.8	101.7	95.6	88.9	83.5	78.3	10
12	136.7	136.7	134.7	132.8	127.3	124.0	119.6	113.5	108.4	103.5	97.8	91.8	87.5	83.3	79.3	75.4	12
14	115.5	115.5	115.0	112.8	110.3	106.2	102.8	99.0	94.1	89.0	84.1	81.3	79.4	77.1	75.0	71.7	14
16	99.5	99.5	99.1	98.2	95.6	93.5	89.6	86.2	82.8	78.9	73.9	71.3	69.5	67.5	65.9	63.9	16
20	74.2	74.5	74.4	74.3	73.8	73.2	71.3	68.8	65.4	61.8	59.1	57.4	56.3	54.5	53.3	51.4	20
24		58.0	58.0	58.0	57.5	57.1	56.5	56.0	54.0	51.0	48.6	46.8	45.8	44.4	43.4	42.2	24
26			51.9	52.0	51.5	51.1	50.5	50.0	49.3	46.6	44.8	43.0	41.8	40.6	39.5	38.4	26
32				38.9	38.6	38.2	37.6	37.0	36.4	35.8	35.0	33.5	32.8	31.9	31.0	30.1	32
38					30.0	29.7	29.1	28.6	27.9	27.3	26.6	25.9	25.3	24.6	24.0	23.3	38
44						23.6	23.1	22.6	21.9	21.3	20.5	19.9	19.6	19.2	18.6	18.0	44
50							18.5	18.1	17.4	16.8	16.1	15.4	15.1	14.7	14.4	14.0	50
55								15.1	14.5	13.9	13.1	12.6	12.2	11.7	11.5	11.0	55
60									12.1	11.5	10.8	10.2	9.8	9.3	8.9	8.3	60
65										9.4	8.7	7.9	7.5	6.9	6.6	6.1	65
70											6.7	5.9	5.5	4.9	4.6	4.1	70
75												4.1	3.7	3.2	2.9	2.3	75
80													2.1				80

TLT 11959002. Estas tablas de cargas sirven únicamente como información.  
Para trabajos de elevación consultar las tablas de cargas de la cabina o el manual.

# Plumín fijo (No. 0906.21)

Pluma principal 88-30°, 20-83 m | Plumín fijo 30°, 7 m

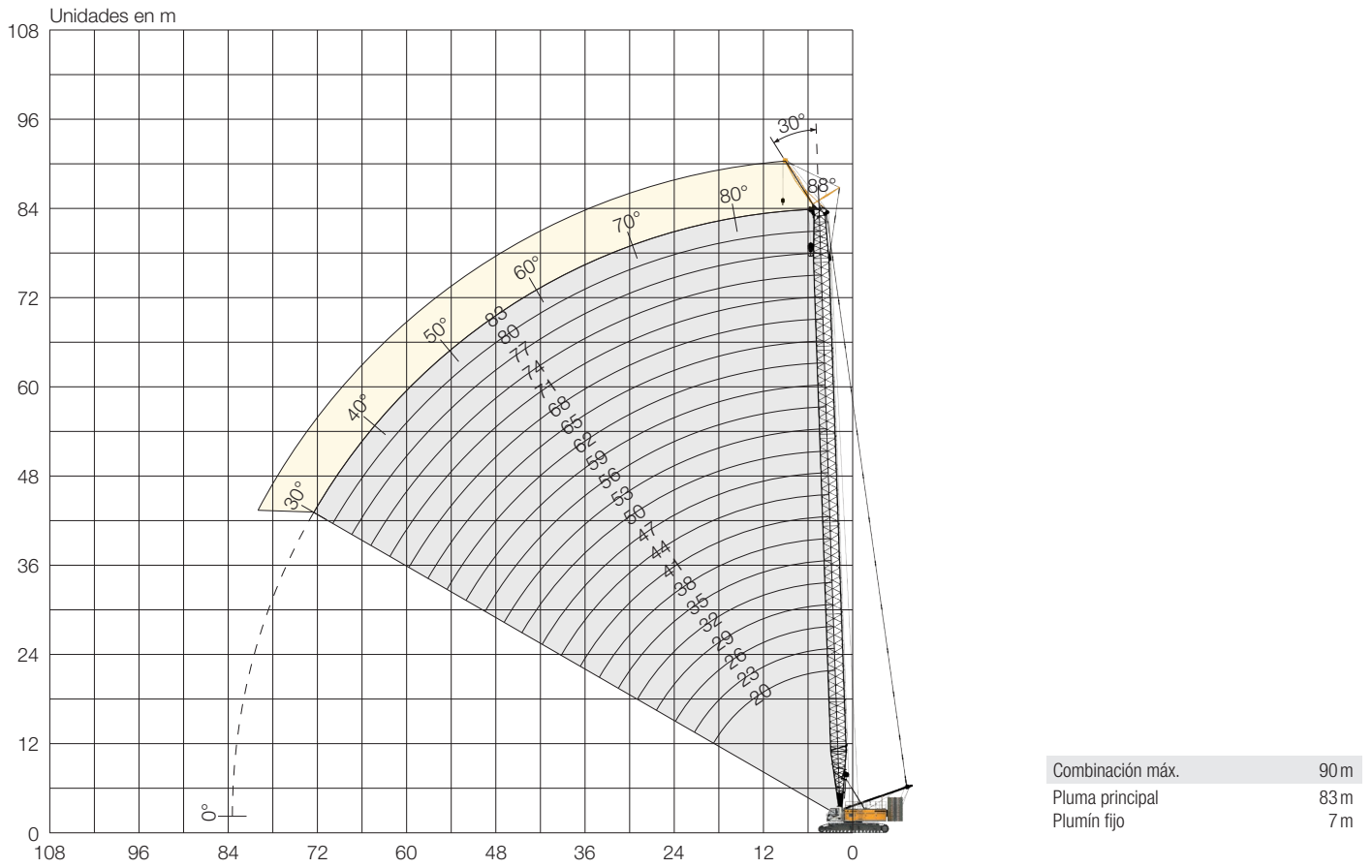

## Configuración de pluma principal (No. 2821.xx)

	Longitud	Número de tramos de pluma principal																					
		20	23	26	29	32	35	38	41	44	47	50	53	56	59	62	65	68	71	74	77	80	83
Pie de pluma	10 m	1	1	1	1	1	1	1	1	1	1	1	1	1	1	1	1	1	1	1	1	1	1
Tramo pluma	3 m	1		1		1		1		1		1		1		1		1		1		1	
Tramo pluma	6 m		1	1			1	1			1	1			1	1			1	1			1
Tramo pluma	12 m				1	1	1	1	2	2	2	2	3	3	3	3	4	4	4	4	5	5	5
Cabeza de pluma	7 m	1	1	1	1	1	1	1	1	1	1	1	1	1	1	1	1	1	1	1	1	1	1
<b>Longitud de pluma (m)</b>		<b>20</b>	<b>23</b>	<b>26</b>	<b>29</b>	<b>32</b>	<b>35</b>	<b>38</b>	<b>41</b>	<b>44</b>	<b>47</b>	<b>50</b>	<b>53</b>	<b>56</b>	<b>59</b>	<b>62</b>	<b>65</b>	<b>68</b>	<b>71</b>	<b>74</b>	<b>77</b>	<b>80</b>	<b>83</b>

Tablas de cargas - plumín fijo 30° (No. 0906.21) | Contrapeso trasero 124t y contrapeso central 57t

**Pluma principal 20m**

Radio [m]	[t]
14	61.6
15	59.6
16	57.4
17	55.5
18	54.2
19	52.9
20	51.6
22	49.2
24	47.8
26	46.9

**Pluma principal 26m**

Radio [m]	[t]
13	67.6
14	65.0
15	62.9
16	61.1
17	59.5
18	57.8
19	56.2
20	54.9
22	52.9
24	50.8
26	49.0
28	47.5
30	43.7
32	39.8

**Pluma principal 32m**

Radio [m]	[t]
11	74.5
12	71.6
14	67.9
16	63.9
18	60.8
20	58.0
22	55.5
24	53.6
26	51.3
28	47.8
30	43.5
32	39.7
34	36.4
36	33.5

**Pluma principal 38m**

Radio [m]	[t]
10	78.1
12	73.7
14	69.5
16	66.5
18	63.1
20	60.5
22	58.0
24	55.4
26	52.4
28	47.3
30	42.9
34	35.9
38	30.4
42	26.1

**Pluma principal 44m**

Radio [m]	[t]
9	81.4
10	79.2
12	74.9
14	71.2
16	68.1
18	65.3
20	62.5
24	57.1
28	46.9
32	38.7
36	32.6
40	27.8
44	23.9
48	20.6

**Pluma principal 50m**

Radio [m]	[t]
9	81.9
10	79.8
12	75.8
14	72.9
16	69.5
20	62.9
24	55.9
28	46.3
32	38.1
36	32.0
40	27.2
44	23.3
48	20.1
50	18.6

**Pluma principal 56m**

Radio [m]	[t]
8.3	82.6
10	80.2
12	76.6
14	73.7
16	70.8
20	65.7
24	54.9
28	45.8
32	37.6
36	31.4
40	26.7
44	22.8
48	19.6
55	15.1

**Pluma principal 62m**

Radio [m]	[t]
8.5	82.1
10	80.6
12	77.3
14	74.2
16	71.7
20	65.2
28	44.6
32	37.0
36	30.8
40	26.0
44	22.1
48	18.9
55	14.4
60	11.9

**Pluma principal 68m**

Radio [m]	[t]
8.7	81.5
10	80.9
12	78.1
14	74.8
16	72.8
20	62.4
28	43.0
32	36.1
36	30.2
40	25.5
44	21.5
48	18.3
55	13.9
65	9.1

**Pluma principal 74m**

Radio [m]	[t]
8.9	80.9
10	80.9
12	77.8
14	75.1
16	72.8
20	62.1
28	41.4
36	29.3
40	24.7
44	20.9
48	17.6
55	13.2
65	8.2
70	6.1

**Pluma principal 80m**

Radio [m]	[t]
9.1	79.4
10	79.4
12	77.3
14	74.8
16	71.7
20	60.0
28	39.9
36	28.2
40	23.9
44	20.3
48	17.0
55	12.5
65	7.4
75	3.5

**Pluma principal 83m**

Radio [m]	[t]
9.2	77.7
10	77.7
12	75.2
14	72.0
16	68.4
20	58.9
28	39.1
36	27.4
40	23.2
44	19.7
48	16.7
55	12.2
65	7.0
75	3.1

TLT 11959002. Estas tablas de cargas sirven únicamente como información. Para trabajos de elevación consultar las tablas de cargas de la cabina o el manual.

# Plumín fijo (No. 1507.20)

Pluma principal 88-30°, 50-83 m | Plumín fijo 30°, 8 m

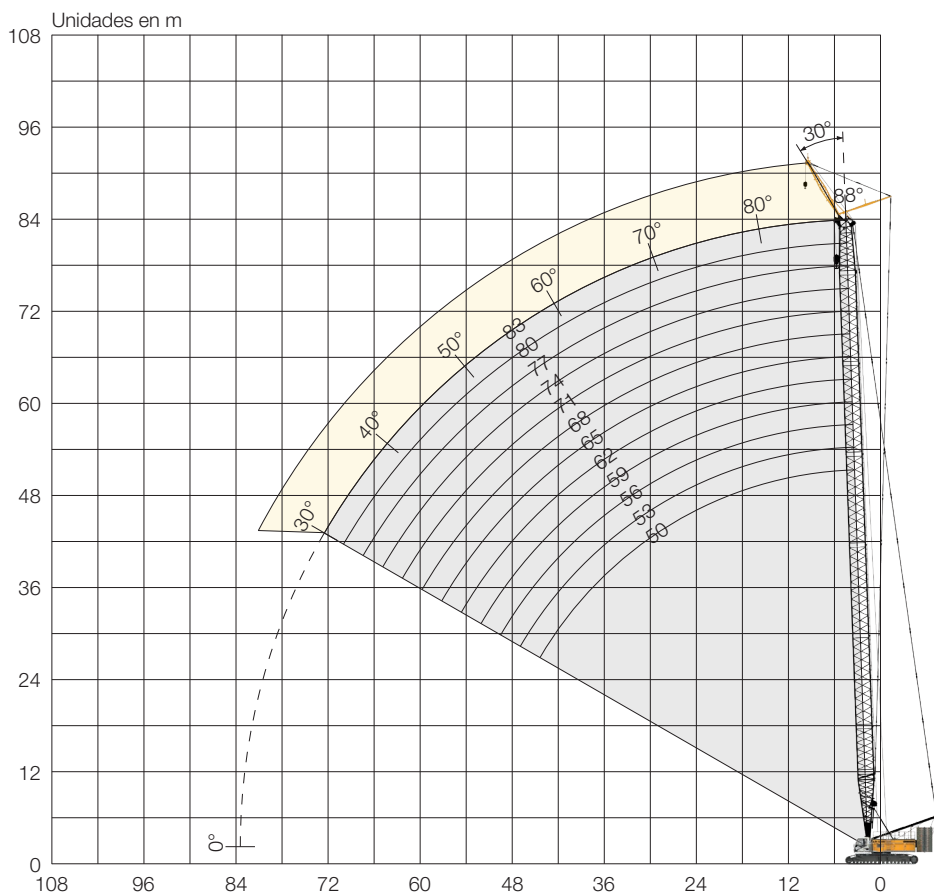

Combinación máx.	91 m
Pluma principal	83 m
Plumín fijo	8 m

## Configuración de pluma principal (No. 2821.xx)

	Longitud	Número de tramos de pluma principal											
		1	1	1	1	1	1	1	1	1	1	1	1
Pie de pluma	10 m	1	1	1	1	1	1	1	1	1	1	1	1
Tramo pluma	3 m	1		1		1		1		1		1	
Tramo pluma	6 m	1			1	1			1	1			1
Tramo pluma	12 m	2	3	3	3	3	4	4	4	4	5	5	5
Cabeza de pluma	7 m	1	1	1	1	1	1	1	1	1	1	1	1
<b>Longitud de pluma (m)</b>		<b>50</b>	<b>53</b>	<b>56</b>	<b>59</b>	<b>62</b>	<b>65</b>	<b>68</b>	<b>71</b>	<b>74</b>	<b>77</b>	<b>80</b>	<b>83</b>

Tablas de cargas - plumín fijo 30° (No. 1507.20) | Contrapeso trasero 124t y contrapeso central 57t

**Pluma principal 50 m**

Radio [m]	[t]
8	117.0
10	117.0
12	110.9
14	103.6
16	89.1
20	70.4
24	56.9
28	45.9
32	37.7
36	31.5
40	26.8
44	22.9
48	19.6
50	18.2

**Pluma principal 53 m**

Radio [m]	[t]
8.1	117.0
10	117.0
12	110.2
14	102.5
16	88.8
20	69.3
24	56.0
28	45.7
32	37.5
36	31.3
40	26.6
44	22.7
48	19.4
55	15.0

**Pluma principal 56 m**

Radio [m]	[t]
8.2	117.0
10	117.0
12	110.6
14	99.9
16	87.2
20	68.1
24	55.0
28	45.4
32	37.2
36	31.0
40	26.2
44	22.3
48	19.1
55	14.6

**Pluma principal 59 m**

Radio [m]	[t]
8.3	117.0
10	117.0
12	111.9
14	97.5
16	85.7
20	66.9
28	44.7
32	36.9
36	30.7
40	25.9
44	22.0
48	18.8
55	14.3
60	11.8

**Pluma principal 62 m**

Radio [m]	[t]
8.5	117.0
10	115.2
12	108.2
14	95.2
16	84.2
20	65.7
28	43.8
32	36.5
36	30.3
40	25.6
44	21.6
48	18.4
55	13.9
60	11.4

**Pluma principal 65 m**

Radio [m]	[t]
8.6	110.3
10	109.3
12	103.7
14	92.0
16	82.7
20	64.7
28	43.1
32	36.2
36	30.1
40	25.3
44	21.4
48	18.2
55	13.7
65	8.9

**Pluma principal 68 m**

Radio [m]	[t]
8.7	103.7
10	103.3
12	97.8
14	88.8
16	81.3
20	63.5
28	42.3
32	35.4
36	29.7
40	24.9
44	21.0
48	17.8
55	13.3
65	8.4

**Pluma principal 71 m**

Radio [m]	[t]
8.8	97.8
10	97.8
12	92.4
14	85.4
16	79.1
20	62.4
28	41.5
36	29.3
40	24.5
44	20.7
48	17.5
55	13.0
65	8.0
70	5.8

**Pluma principal 74 m**

Radio [m]	[t]
8.9	91.8
10	91.8
12	87.0
14	81.5
16	75.9
20	61.3
28	40.7
36	28.6
40	24.2
44	20.3
48	17.1
55	12.6
65	7.4
75	3.5

**Pluma principal 77 m**

Radio [m]	[t]
9	86.8
10	86.8
12	82.7
14	78.4
16	73.8
20	60.3
28	39.9
36	28.1
40	23.8
44	20.1
48	16.8
55	12.3
65	7.1
75	3.2

**Pluma principal 80 m**

Radio [m]	[t]
9.2	81.9
10	81.9
12	78.5
14	74.8
16	70.8
20	59.2
28	39.1
36	27.4
40	23.2
44	19.6
48	16.4
55	11.9
65	6.6
75	2.7

**Pluma principal 83 m**

Radio [m]	[t]
9.3	76.9
10	76.9
12	74.3
14	71.1
16	67.5
20	58.2
28	38.4
36	26.7
40	22.5
44	19.0
48	16.1
55	11.5
65	6.2
75	2.3

TLT 11962213. Estas tablas de cargas sirven únicamente como información. Para trabajos de elevación consultar las tablas de cargas de la cabina o el manual.

# Plumín fijo (No. 1008.xx)

Pluma principal 88-30°, 20-83 m | Plumín fijo 15° y 30°, 11-26 m

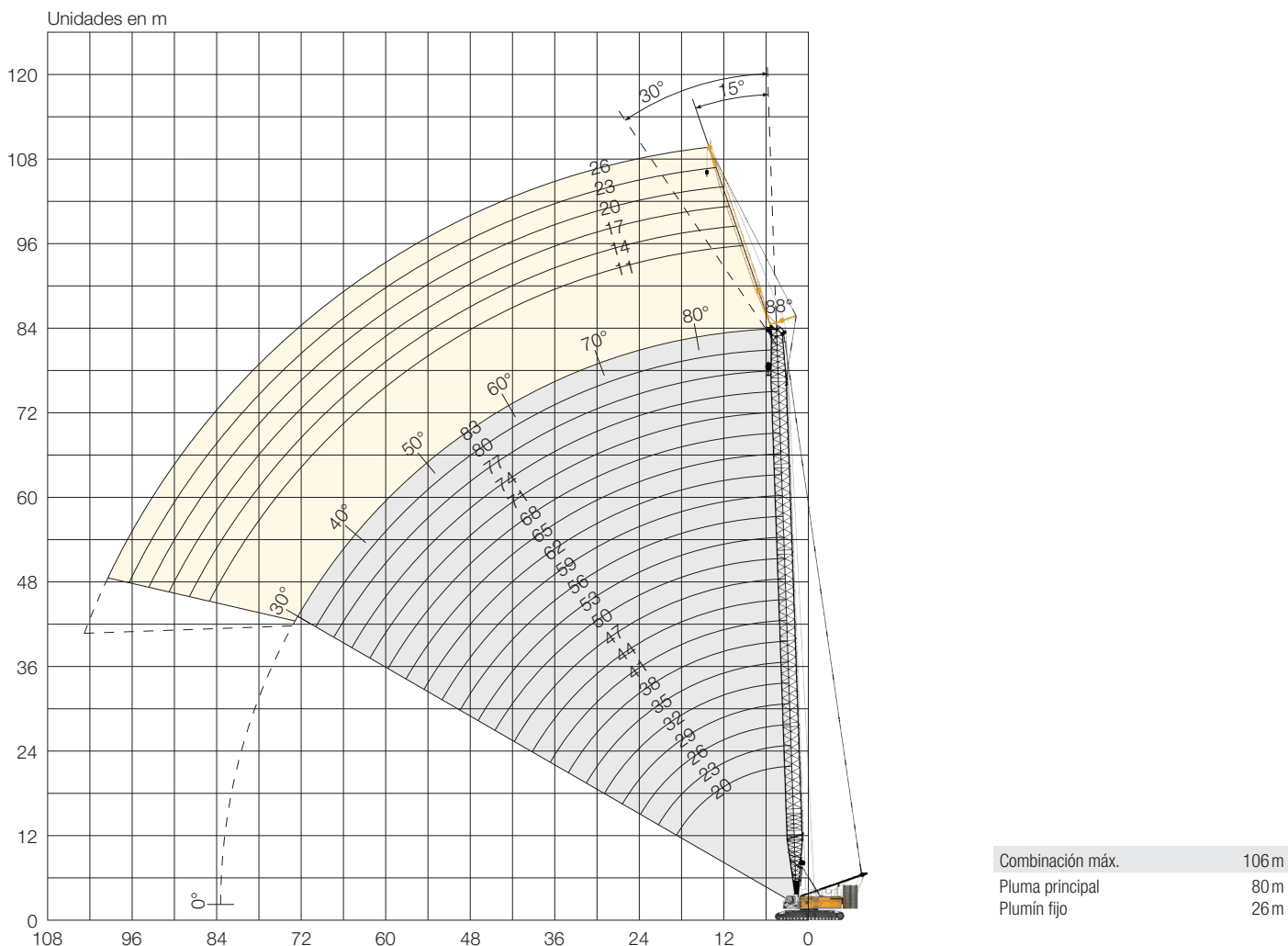

## Configuración de plumín fijo (No. 1008.xx)

	Longitud	Número de tramos de plumín fijo					
		1	1	1	1	1	1
Pie de plumín	5.5 m	1	1	1	1	1	1
Tramo plumín	3 m		1		1		1
Tramo plumín	6 m			1	1	2	2
Cabeza de plumín	5.5 m	1	1	1	1	1	1
<b>Longitud de plumín (m)</b>		<b>11</b>	<b>14</b>	<b>17</b>	<b>20</b>	<b>23</b>	<b>26</b>

Tablas de cargas - plumín fijo 15° (No. 1008.xx) | Contrapeso trasero 124t y contrapeso central 57t

**Pluma principal 20 m**

Radio [m]	Longitud de plumín [m]		
	11 [t]	17 [t]	26 [t]
13	44.2		
14	43.9		
16	40.7	27.4	
18	36.1	24.9	16.3
20	32.8	22.8	15.3
24	28.6	19.1	13.6
28	24.7	16.6	11.9
32		15.1	10.6
36		13.6	9.5
40			8.7
44			8.0

**Pluma principal 29 m**

Radio [m]	Longitud de plumín [m]		
	11 [t]	17 [t]	26 [t]
11	45.0		
12	45.0		
14	44.6	31.5	
16	43.8	29.5	17.8
18	43.2	27.2	16.7
20	39.1	25.2	15.8
24	33.2	22.0	14.4
28	30.1	19.2	13.3
32	26.7	17.2	11.8
36	24.0	15.6	10.7
40		14.7	9.8
44		13.5	9.0
48			8.5

**Pluma principal 41 m**

Radio [m]	Longitud de plumín [m]		
	11 [t]	17 [t]	26 [t]
10	45.0	36.6	
12	45.0	34.3	
14	45.0	32.5	19.1
16	44.8	30.6	18.0
18	43.3	29.1	17.2
20	42.1	27.6	16.3
24	38.6	24.6	14.9
28	34.4	22.3	13.9
32	31.2	19.9	13.2
36	29.3	18.2	12.0
40	26.7	16.1	11.0
44	24.4	15.6	10.3
48	21.3	15.0	50.8
55			8.7
60			8.1

**Pluma principal 59 m**

Radio [m]	Longitud de plumín [m]		
	11 [t]	17 [t]	26 [t]
7.2	45.0		
8	45.0		
10	45.0	36.1	
12	45.0	34.3	
14	44.8	32.5	19.1
16	43.2	31.1	18.2
18	41.9	29.8	16.6
20	40.9	27.5	16.0
24	38.3	26.6	15.4
28	36.5	24.6	14.6
32	33.5	23.4	13.9
36	30.9	21.5	13.4
40	26.3	19.7	12.7
44	22.4	18.6	11.8
48	19.3	17.4	11.1
55	14.9	15.7	10.0
60	12.4	13.3	9.4
65		11.1	8.9
70		9.3	8.5
75			8.1

**Pluma principal 77 m**

Radio [m]	Longitud de plumín [m]		
	11 [t]	17 [t]	26 [t]
8	45.0		
10	45.0		
12	44.5	33.2	
14	42.7	32.0	18.4
16	41.4	30.5	17.8
18	39.5	29.4	17.2
20	37.5	28.4	16.5
24	34.7	26.7	15.5
28	32.7	25.5	14.7
32	31.1	24.2	14.2
36	28.1	23.2	13.7
40	23.9	22.3	13.2
44	20.4	20.0	12.9
48	17.2	18.2	12.2
55	12.8	13.8	11.1
60	10.2	11.3	10.5
65	7.9	8.8	9.6
70	5.4	6.8	8.0
75	4.0	4.9	6.1
80	2.4	3.3	4.5
85			3.0

**Pluma principal 83 m**

Radio [m]	Longitud de plumín [m]	
	11 [t]	14 [t]
8.1	45.0	
10	44.6	42.1
12	44.0	40.0
14	41.7	38.2
16	39.8	36.5
18	38.1	35.2
20	35.9	33.8
24	32.6	31.1
28	30.3	29.3
32	28.5	27.3
36	26.7	25.7
40	22.6	23.0
44	19.2	19.6
48	16.3	16.7
55	12.0	12.6
60	9.3	9.8
65	4.8	7.4
70	3.1	5.3
75		3.5

TLT 11959002. Estas tablas de cargas sirven únicamente como información.  
Para trabajos de elevación consultar las tablas de cargas de la cabina o el manual.

Tablas de cargas - plumín fijo 30° (No. 1008.xx) | Contrapeso trasero 124 t y contrapeso central 57 t

**Pluma principal 20 m**

Radio	Longitud de plumín [m]		
	11	17	26
[m]	[t]	[t]	[t]
18	17.2	17.2	
20	15.9	15.9	
24	14.5	14.5	9.9
28	12.9	12.9	8.9
32	11.8	11.8	8.0
36	11.3	11.3	7.4
40			6.9
44			6.6

**Pluma principal 29 m**

Radio	Longitud de plumín [m]		
	11	17	26
[m]	[t]	[t]	[t]
13	33.3		
14	31.8		
16	30.1	19.3	
18	29.9	18.0	
20	27.1	17.1	11.5
24	23.9	15.3	10.3
28	21.7	14.2	9.4
32	20.0	13.0	8.6
36	19.0	12.1	8.0
40		11.6	7.5
44		11.3	7.0
48			6.7

**Pluma principal 41 m**

Radio	Longitud de plumín [m]		
	11	17	26
[m]	[t]	[t]	[t]
11	37.9		
12	36.4		
14	34.1	21.2	
16	31.8	19.9	
18	30.1	18.9	
20	29.7	17.9	11.7
24	26.8	16.4	10.7
28	24.4	15.2	9.8
32	22.6	14.4	9.1
36	21.1	13.3	8.6
40	19.9	12.6	8.0
44	19.2	12.0	7.6
48	18.6	11.6	7.3
55		11.2	6.8
60			6.6

**Pluma principal 59 m**

Radio	Longitud de plumín [m]		
	11	17	26
[m]	[t]	[t]	[t]
9.9	45.0		
10	45.0		
12	37.8		
14	35.8	21.4	
16	34.2	20.5	
18	32.4	19.6	
20	30.9	18.2	11.9
24	29.9	17.5	11.1
28	27.6	16.5	10.4
32	25.9	15.5	9.7
36	24.1	15.1	9.2
40	22.7	14.1	8.7
44	21.2	13.3	8.4
48	19.7	12.8	8.0
55	15.2	12.0	7.4
60	12.6	11.6	7.1
65	10.4	11.2	6.9
70		9.4	6.7
75			6.6
80			6.4

**Pluma principal 77 m**

Radio	Longitud de plumín [m]		
	11	17	26
[m]	[t]	[t]	[t]
12	38.0		
14	36.6		
16	35.0	20.7	
18	33.7	20.0	
20	32.5	19.3	11.9
24	30.3	18.2	11.3
28	29.4	17.2	10.7
32	27.8	16.4	10.1
36	26.5	15.5	9.6
40	24.1	15.1	9.2
44	21.0	14.6	8.8
48	17.8	13.8	8.5
55	13.3	13.0	7.9
60	10.7	11.7	7.6
65	8.2	9.4	7.3
70	6.1	7.2	7.0
75	4.2	5.3	6.7
80	2.6	3.6	5.0
85		2.0	3.4

**Pluma principal 83 m**

Radio	Longitud de plumín [m]	
	11	14
[m]	[t]	[t]
10.7	37.5	
12	37.3	
14	35.7	28.0
16	34.2	26.9
18	32.8	25.9
20	31.8	24.9
24	29.4	23.4
28	27.8	22.0
32	26.3	20.8
36	25.2	19.7
40	23.5	18.9
44	19.9	17.7
48	17.0	16.3
55	12.6	13.2
60	9.8	10.4
65	7.3	7.9
70	5.2	5.8
75	3.3	3.9
80		2.2

TLT 11959002. Estas tablas de cargas sirven únicamente como información.  
Para trabajos de elevación consultar las tablas de cargas de la cabina o el manual.



# Plumín fijo (No. 1713.xx)

Pluma principal 88-30°, 20-80m | Plumín fijo 15° y 30°, 14-35m

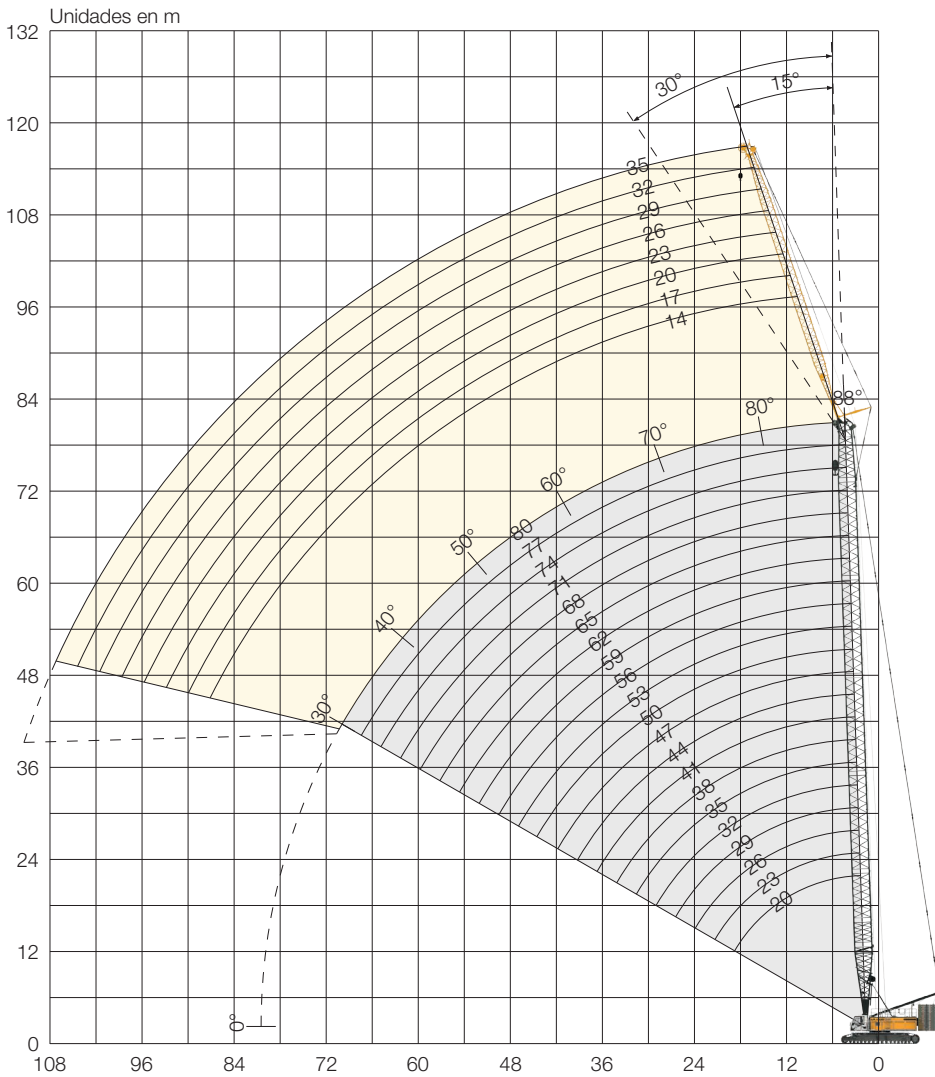

## Configuración de plumín fijo (No. 1713.xx)

	Longitud		Número de tramos de plumín fijo							
	7 m	3 m	1	1	1	1	1	1	1	
Pie de plumín	7 m	3 m	1	1	1	1	1	1	1	
Tramo plumín	3 m	6 m		1	1		1	1	1	
Tramo plumín	6 m	12 m			1	1	1	1	1	
Tramo plumín	12 m					1	1	1	1	
Cabeza de plumín	7 m		1	1	1	1	1	1	1	
<b>Longitud de plumín (m)</b>			<b>14</b>	<b>17</b>	<b>20</b>	<b>23</b>	<b>26</b>	<b>29</b>	<b>32</b>	<b>35</b>

Tablas de cargas - plumín fijo 15° (No. 1713.xx) | Contrapeso trasero 124 t y contrapeso central 57 t

**Pluma principal 20 m**

Radio	Longitud de plumín [m]		
	14	23	35
[m]	[t]	[t]	[t]
13	46.0		
14	43.8	30.0	
16	38.8	26.5	19.4
18	35.1	24.2	17.5
20	31.7	22.0	16.1
24	27.4	18.9	13.8
28	24.0	16.5	11.9
32	21.7	14.7	10.6
36		13.3	9.4
40		12.2	8.5
44			7.7
48			7.1
52			6.6

**Pluma principal 32 m**

Radio	Longitud de plumín [m]		
	14	23	35
[m]	[t]	[t]	[t]
10	58.3		
12	54.6	35.0	
14	48.6	31.6	
16	45.0	29.5	19.7
18	41.1	26.7	18.2
20	37.9	24.9	16.9
24	32.7	21.7	14.7
28	29.6	19.4	13.1
32	26.3	17.3	11.7
36	24.0	15.9	10.6
40	22.3	14.5	9.6
44	15.1	13.5	8.9
48		12.7	8.2
52		12.0	7.6
60			6.8

**Pluma principal 47 m**

Radio	Longitud de plumín [m]		
	14	23	35
[m]	[t]	[t]	[t]
10	60.0		
12	56.9	35.3	
14	53.9	32.7	
16	49.2	30.1	19.9
18	45.7	28.7	18.7
20	43.7	26.5	17.5
24	38.2	23.8	15.7
28	34.4	21.3	14.1
32	31.0	19.6	12.9
36	29.0	17.9	11.7
40	26.7	16.5	10.9
44	23.7	15.3	10.0
48	20.5	14.5	9.3
55	16.1	13.1	8.3
60		12.4	7.7
65			7.2
70			6.8

**Pluma principal 62 m**

Radio	Longitud de plumín [m]		
	14	23	35
[m]	[t]	[t]	[t]
9	60.0		
10	60.0		
12	59.6	35.3	
14	55.6	33.6	
16	52.9	31.6	
18	49.2	30.1	18.9
20	46.2	28.7	18.1
24	42.4	25.5	16.3
28	38.2	23.5	14.9
32	35.2	21.5	13.7
36	30.7	20.1	12.7
40	25.9	18.7	11.7
44	22.0	17.5	11.0
48	18.8	16.5	10.3
55	14.5	14.7	9.2
60	12.0	12.8	8.7
65	9.8	10.7	8.1
70	7.7	8.7	7.7
75		6.8	7.3
80			6.2
90			3.4

**Pluma principal 80 m**

Radio	Longitud de plumín [m]	
	14	17
[m]	[t]	[t]
10	58.4	
12	56.7	49.0
14	54.8	46.0
16	52.4	44.3
18	50.7	41.8
20	48.8	40.0
24	44.4	36.2
28	38.7	33.4
32	32.3	30.2
36	27.2	27.2
40	23.1	23.3
44	19.6	19.8
48	16.7	16.9
55	12.4	12.7
60	9.6	10.0
65	6.8	7.6
70	5.2	5.5
75	3.4	3.7
80		2.0

TLT 11959002. Estas tablas de cargas sirven únicamente como información.  
Para trabajos de elevación consultar las tablas de cargas de la cabina o el manual.

Tablas de cargas - plumín fijo 30° (No. 1713.xx) | Contrapeso trasero 124 t y contrapeso central 57 t

**Pluma principal 20 m**

Radio [m]	Longitud de plumín [m]		
	14 [t]	23 [t]	35 [t]
15	46.0		
16	30.4		
18	28.1	19.3	
20	26.5	18.0	
24	23.7	15.9	11.3
28	21.7	14.4	10.0
32	20.5	13.1	9.1
36		12.2	8.2
40		11.6	7.6
44			7.0
48			6.6
52			6.3

**Pluma principal 32 m**

Radio [m]	Longitud de plumín [m]		
	14 [t]	23 [t]	35 [t]
13	35.6		
14	34.4		
16	32.3		
18	30.6	20.2	
20	29.0	19.1	
24	26.5	17.3	11.5
28	24.3	15.8	10.5
32	22.8	14.7	9.6
36	21.5	13.6	8.8
40	20.7	12.9	8.2
44	20.1	12.2	7.7
48		11.8	7.2
52		11.7	6.8
60			6.4
65			6.3

**Pluma principal 47 m**

Radio [m]	Longitud de plumín [m]		
	14 [t]	23 [t]	35 [t]
12	37.5		
14	35.6		
16	33.9		
18	32.4	20.1	
20	31.0	19.3	
24	28.6	17.8	11.6
28	26.7	16.6	10.7
32	25.1	15.5	10.0
36	23.7	14.7	9.3
40	22.7	13.8	8.5
44	21.8	13.2	8.3
48	20.9	12.6	7.9
55	16.2	11.9	7.2
60		11.6	6.9
65			6.6
70			6.4

**Pluma principal 62 m**

Radio [m]	Longitud de plumín [m]		
	14 [t]	23 [t]	35 [t]
12	37.2		
14	36.0		
16	34.6		
18	33.4	20.7	
20	32.2	19.9	
24	30.1	18.6	
28	28.4	17.5	10.9
32	26.9	16.6	10.3
36	25.6	15.7	9.7
40	24.3	15.0	9.2
44	22.7	14.3	8.7
48	19.4	13.7	8.3
55	14.9	12.9	7.7
60	12.3	12.3	7.3
65	10.0	11.1	7.0
70	7.9	9.1	6.8
75		7.1	6.5
80			6.3
90			3.6

**Pluma principal 80 m**

Radio [m]	Longitud de plumín [m]	
	14 [t]	17 [t]
13	36.5	
14	36.4	
16	35.2	28.7
18	34.1	17.8
20	33.1	26.9
24	31.3	25.5
28	29.7	24.1
32	28.1	23.2
36	36.4	22.2
40	24.2	21.3
44	20.6	20.6
48	17.5	17.9
55	13.1	13.4
60	10.2	10.7
65	7.7	8.2
70	5.6	6.0
75	3.7	4.1
80		2.4

TLT 11959002. Estas tablas de cargas sirven únicamente como información.  
Para trabajos de elevación consultar las tablas de cargas de la cabina o el manual.

# Plumín abatible (No. 1916.xx)

Pluma principal 88-45°, 29-71 m | Plumín abatible 78-15°, 20-95 m

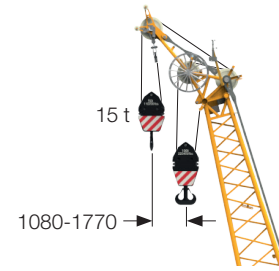
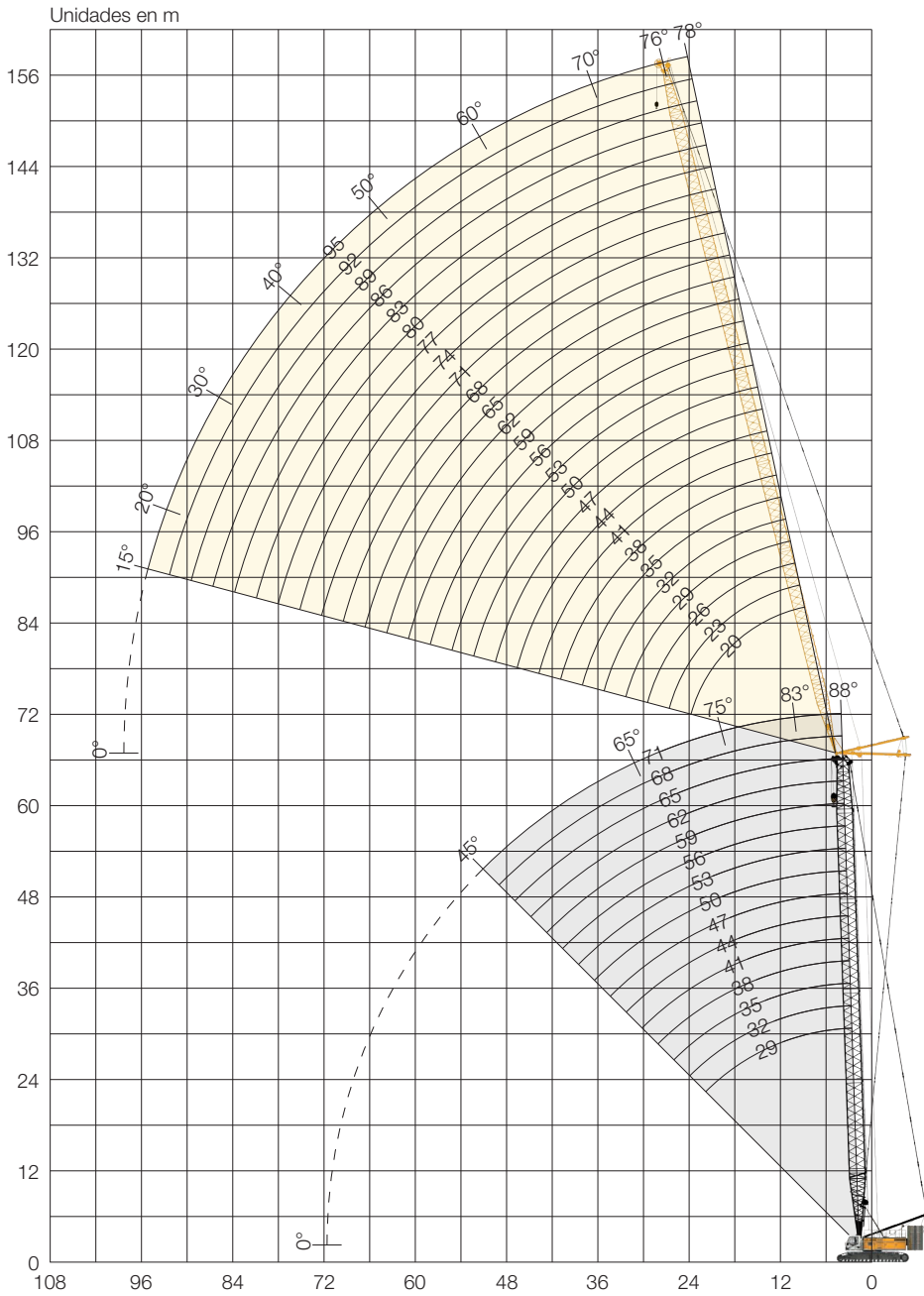

**Plumín auxiliar fijo 15 t** (opción)  
 La carga máx. del plumín auxiliar es de 15 t. Este plumín tiene su propia tabla de carga y requiere su correcta selección en el programa del limitador de carga en la cabina.

Combinación máx.	160 m
Pluma principal	65 m
Plumín abatible	95 m
Combinación máx.	115 m
Pluma principal	71 m
Plumín abatible	44 m

## Configuración de plumín abatible (No. 1916.xx)

	Longitud	Número de tramos de plumín abatible																									
		20	23	26	29	32	35	38	41	44	47	50	53	56	59	62	65	68	71	74	77	80	83	86	89	92	95
Pie de plumín	7 m	1	1	1	1	1	1	1	1	1	1	1	1	1	1	1	1	1	1	1	1	1	1	1	1	1	1
Tramo plumín	3 m				1				1				1				1				1				1		
Tramo plumín	6 m	1	1				1	1				1	1				1	1			1	1			1	1	
Tramo plumín	12 m			1	1	1	1	2	2	2	3	3	3	3	4	4	4	4	5	5	5	5	6	6	6	6	6
Cabeza de plumín	7 m	1	1	1	1	1	1	1	1	1	1	1	1	1	1	1	1	1	1	1	1	1	1	1	1	1	1
<b>Longitud de plumín (m)</b>		<b>20</b>	<b>23</b>	<b>26</b>	<b>29</b>	<b>32</b>	<b>35</b>	<b>38</b>	<b>41</b>	<b>44</b>	<b>47</b>	<b>50</b>	<b>53</b>	<b>56</b>	<b>59</b>	<b>62</b>	<b>65</b>	<b>68</b>	<b>71</b>	<b>74</b>	<b>77</b>	<b>80</b>	<b>83</b>	<b>86</b>	<b>89</b>	<b>92</b>	<b>95</b>
Plumín auxiliar fijo aplicable		✓	✓	✓	✓	✓	✓	✓	✓	✓	✓	✓	✓	✓	✓	✓	✓	✓	✓	✓	✓	✓	✓	✓	✓	✓	✓

**Pluma principal 29 m | 88°**

Radio	Longitud de plumín [m]				
	20	41	65	83	95
[m]	[t]	[t]	[t]	[t]	[t]
14		39.1			
16	61.5	36.0			
18	54.8	33.3	17.5		
20	48.3	30.8	16.8		
22	38.8	28.6	16.1	9.6	
24		26.9	15.5	9.2	6.2
28		23.8	14.5	8.6	5.8
36		19.3	13.2	7.7	5.2
42		15.9	12.3	7.2	4.9
50			11.2	6.6	4.6
60			9.4	6.0	3.5
65			7.7	5.6	3.2
75				4.9	2.5
80				4.4	2.3

**Pluma principal 50 m | 88°**

Radio	Longitud de plumín [m]				
	20	41	65	83	95
[m]	[t]	[t]	[t]	[t]	[t]
9.1	78.7				
10	75.8				
14	67.1	37.3			
18	49.8	32.5			
22	41.1	28.4	15.4		
24		26.9	14.8	8.9	
28		24.1	14.0	8.4	5.6
36		19.8	12.8	7.6	4.9
42		16.9	12.0	7.0	4.5
50			11.1	6.4	4.1
60			9.7	5.9	3.4
65			8.3	5.6	3.2
75				5.1	2.5
80				4.6	2.2
85				3.7	

**Pluma principal 71 m | 88°**

Radio	Longitud de plumín [m]	
	32	44
[m]	[t]	[t]
12.3	42.5	
14	41.8	
18	37.8	27.2
22	3.5	24.3
24	31.6	22.9
28	28.6	20.9
36	21.7	17.6
42		15.4

TLT 11959002. Estas tablas de cargas sirven únicamente como información. Para trabajos de elevación consultar las tablas de cargas de la cabina o el manual.

Tablas de cargas - plumín abatible (No. 1916.xx) | Contrapeso trasero 124 t y contrapeso central 57 t

**Pluma principal 29 m | 83°**

Radio	Longitud de plumín [m]				
	20	41	65	83	95
[m]	[t]	[t]	[t]	[t]	[t]
12.6	80.0				
14	77.1				
18	62.0				
20	56.5	33.5			
22	50.8	28.6			
24	43.3	26.9			
28		23.8	15.0		
36		19.3	13.6	8.0	5.4
42		15.9	12.6	7.4	4.9
50			11.6	6.8	4.4
60			10.3	6.2	3.7
65			7.7	5.8	3.4
75				5.3	2.7
80				4.8	2.5
85				4.4	2.2

**Pluma principal 50 m | 83°**

Radio	Longitud de plumín [m]				
	20	41	65	83	95
[m]	[t]	[t]	[t]	[t]	[t]
15.1	70.4				
18	59.9				
22	49.6	31.9			
24	45.8	29.9			
28	37.1	27.1			
36		22.6	13.4	7.8	
42		19.5	12.7	7.3	4.8
50			11.8	6.7	4.3
60			10.7	6.0	3.7
65			9.8	5.8	3.4
75				5.3	2.8
80				5.0	2.5
85				4.7	2.3
90					2.1

**Pluma principal 71 m | 83°**

Radio	Longitud de plumín [m]	
	32	44
[m]	[t]	[t]
21.2	37.7	
22	37.6	
24	36.2	
28	33.4	24.0
36	27.1	20.3
42	22.7	17.9
50		15.2

TLT 11959002. Estas tablas de cargas sirven únicamente como información. Para trabajos de elevación consultar las tablas de cargas de la cabina o el manual.

Tablas de cargas - plumín abatible (No. 1916.xx) | Contrapeso trasero 124 t y contrapeso central 57 t

**Pluma principal 29 m | 75°**

Radio	Longitud de plumín [m]				
	20	41	65	83	95
[m]	[t]	[t]	[t]	[t]	[t]
20	66.7				
22	59.7				
24	54.6				
28	45.0	27.2			
36		23.7			
42		20.2	13.2		
50		16.2	12.2	7.0	
60			11.0	6.3	4.0
65			10.3	6.1	3.6
75				5.6	3.0
80				5.3	2.7
85				5.0	2.4
90				4.7	2.2

**Pluma principal 50 m | 75°**

Radio	Longitud de plumín [m]				
	20	41	65	83	95
[m]	[t]	[t]	[t]	[t]	[t]
25	49.7				
28	44.5				
34	37.2	27.5			
42		23.5			
50		19.4	12.5		
55		17.1	11.9	6.8	
60			11.5	6.5	4.1
65			11.1	6.2	3.8
75			9.5	5.7	3.2
80				5.5	3.0
85				5.3	2.7
90				5.1	2.4
95				4.1	2.2

**Pluma principal 71 m | 75°**

Radio	Longitud de plumín [m]	
	32	44
[m]	[t]	[t]
36	26.3	
42	22.8	20.3
50	19.4	17.2
55		15.6
60		14.4

TLT 11959002. Estas tablas de cargas sirven únicamente como información. Para trabajos de elevación consultar las tablas de cargas de la cabina o el manual.

# Plumín abatible (No. 2316.xx)

Pluma principal 88-45°, 20-68 m | Plumín abatible 78-15°, 20-113 m

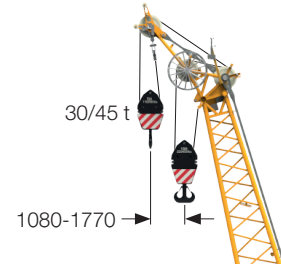
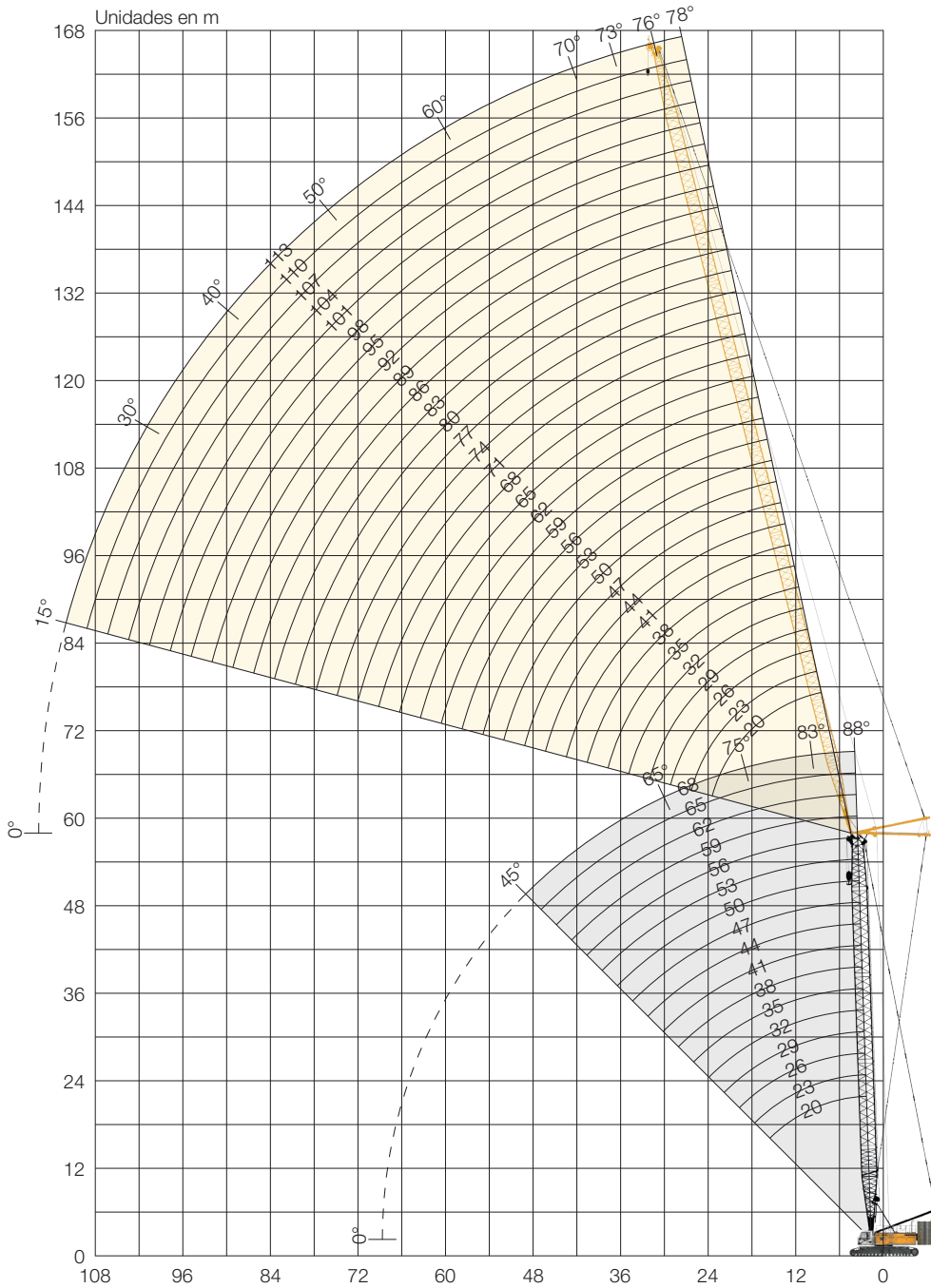

**Plumín auxiliar fijo 30/45 t** (opción)  
 La carga máx. del plumín auxiliar es de 30/45 t. Este plumín tiene su propia tabla de carga y requiere su correcta selección en el programa del limitador de carga en la cabina.

Combinación máx.	169 m
Pluma principal	56 m
Plumín abatible	113 m
Combinación máx.	106 m
Pluma principal	68 m
Plumín abatible	38 m

## Configuración de plumín abatible (No. 2316.xx)

	Longitud		Número de tramos de plumín abatible																																	
	20	23	26	29	32	35	38	41	44	47	50	53	56	59	62	65	68	71	74	77	80	83	86	89	92	95	98	101	104	107	110	113				
Pie de plumín	10 m	1	1	1	1	1	1	1	1	1	1	1	1	1	1	1	1	1	1	1	1	1	1	1	1	1	1	1	1	1	1	1	1	1	1	
Tramo plumín	3 m		1		1		1		1		1		1		1		1		1		1		1		1		1		1		1		1		1	
Tramo plumín	6 m			1	1		1	1		1	1		1	1		1	1		1	1		1	1		1	1		1	1		1	1		1	1	
Tramo plumín	12 m					1	1	1	1	2	2	2	2	3	3	3	3	4	4	4	4	5	5	5	5	6	6	6	6	7	7	7	7	7	7	
Cabeza de plumín	10 m	1	1	1	1	1	1	1	1	1	1	1	1	1	1	1	1	1	1	1	1	1	1	1	1	1	1	1	1	1	1	1	1	1	1	
<b>Longitud de plumín (m)</b>		<b>20</b>	<b>23</b>	<b>26</b>	<b>29</b>	<b>32</b>	<b>35</b>	<b>38</b>	<b>41</b>	<b>44</b>	<b>47</b>	<b>50</b>	<b>53</b>	<b>56</b>	<b>59</b>	<b>62</b>	<b>65</b>	<b>68</b>	<b>71</b>	<b>74</b>	<b>77</b>	<b>80</b>	<b>83</b>	<b>86</b>	<b>89</b>	<b>92</b>	<b>95</b>	<b>98</b>	<b>101</b>	<b>104</b>	<b>107</b>	<b>110</b>	<b>113</b>			
Plumín auxiliar fijo aplicable		✓	✓	✓	✓	✓	✓	✓	✓	✓	✓	✓	✓	✓	✓	✓	✓	✓	✓	✓	✓	✓	✓	✓	✓	✓	✓	✓	✓	✓	✓	✓	✓	✓	✓	✓



Tablas de cargas - plumín abatible (No. 2316.xx) | Contrapeso trasero 124t y contrapeso central 57t

**Pluma principal 20 m | 88°**

Radio [m]	Longitud de plumín [m]							
	20 [t]	41 [t]	53 [t]	65 [t]	77 [t]	89 [t]	101 [t]	110 [t]
12.4		80.5						
15		65.0	57.6					
17	59.1	52.8	52.3					
18	53.7	48.9	47.3	40.4				
20	45.1	41.9	40.4	37.6	28.6			
22	39.4	35.5	34.3	33.7	28.1			
24		31.4	30.1	29.4	26.3	19.1		
26		28.4	27.0	25.8	24.5	18.4	13.7	
28		25.9	24.2	23.1	21.9	17.9	13.4	10.5
36		18.8	17.6	16.1	15.0	14.0	11.4	9.2
42		15.4	14.2	12.7	11.8	10.3	9.4	8.4
50			11.0	9.8	8.5	7.3	6.2	5.5
60				7.2	6.0	4.7	3.7	2.9
65				6.1	5.1	3.8	2.7	
75					3.5	2.3		

**Pluma principal 32m | 88°**

Radio [m]	Longitud de plumín [m]							
	20 [t]	41 [t]	56 [t]	65 [t]	77 [t]	89 [t]	101 [t]	113 [t]
11	117.0							
13	110.6	76.0						
16	82.8	71.2	49.9					
18	68.6	63.2	48.8	37.2				
22	49.0	46.4	42.3	34.9	26.8			
24		40.4	39.0	33.2	25.8	18.3		
26		36.1	35.1	31.7	25.1	17.8	13.0	
28		32.5	31.5	30.3	24.4	17.3	12.8	9.3
36		23.5	22.3	21.6	20.2	15.9	11.6	8.5
42		19.4	18.2	17.2	16.6	13.8	10.9	7.8
55			12.3	11.3	10.6	9.2	8.6	6.8
65				8.5	7.5	6.3	5.4	4.5
75					5.4	4.2	3.2	2.3
80						3.4	2.3	
85						2.6		

**Pluma principal 41 m | 88°**

Radio [m]	Longitud de plumín [m]							
	20 [t]	41 [t]	53 [t]	65 [t]	77 [t]	89 [t]	101 [t]	113 [t]
8.8	117.0							
14	96.2	69.4						
16	78.4	67.1	50.5					
19	60.3	57.0	48.1	35.5				
22	47.6	45.0	41.7	33.6	25.4			
24		39.3	38.1	32.1	24.5	17.6		
26		35.2	33.8	30.5	23.8	17.2	12.6	
28		31.8	30.3	29.4	23.2	16.8	12.5	
38		21.7	20.3	19.4	18.0	14.9	11.1	8.0
44		15.1	16.6	15.7	14.7	12.7	10.2	7.4
55			12.1	11.1	10.2	8.9	8.1	6.3
65				8.3	7.3	6.2	5.2	4.3
75					5.3	4.1	3.1	2.2
80						3.3	2.3	
85						2.6		

**Pluma principal 56 m | 88°**

Radio [m]	Longitud de plumín [m]							
	20 [t]	41 [t]	53 [t]	65 [t]	77 [t]	92 [t]	101 [t]	113 [t]
9.3	101.3							
14	83.1	57.6						
17	65.5	55.4	43.1					
19	56.1	49.4	42.0	31.5				
22	45.2	40.6	37.3	30.4	22.6			
24	39.3	35.6	34.0	29.3	22.2			
26		32.1	30.6	27.5	21.6	14.5		
28		29.2	27.7	26.2	21.1	14.2	11.5	
38		20.1	18.8	17.9	16.5	12.9	10.3	7.4
44		16.8	15.5	14.5	13.5	11.0	9.4	6.9
55			11.4	10.3	9.4	7.9	7.2	5.4
65				7.8	6.7	5.4	4.6	3.8
70					5.8	4.4	3.6	2.7
75					4.9	3.5	2.8	
85						2.1		

**Pluma principal 59 m | 88°**

Radio [m]	Longitud de plumín [m]							
	20 [t]	41 [t]	53 [t]	65 [t]	77 [t]	89 [t]	101 [t]	104 [t]
9.4	94.8							
14	79.3	55.6						
17	63.1	53.7	41.8					
19	54.1	48.3	40.7	30.6				
22	43.5	40.2	36.4	29.7	22.2			
24	38.0	35.4	33.3	28.7	21.8	15.5		
28		29.0	27.3	25.6	20.7	15.1	11.2	10.4
32		24.8	23.2	21.9	19.7	14.6	10.9	10.2
36		21.4	19.9	18.9	17.5	14.0	10.5	9.9
40		19.0	17.5	16.4	15.1	12.8	10.0	9.4
44		16.8	15.3	14.3	13.3	11.2	9.3	8.9
55			11.3	10.2	9.3	7.8	7.0	6.7
65				7.8	6.6	5.4	4.4	4.2
75					4.8	3.6	2.7	2.5
85						2.2		

**Pluma principal 65 m | 88°**

Radio [m]	Longitud de plumín [m]		
	20 [t]	41 [t]	53 [t]
9.6	84.8		
14	73.6	50.7	
17	60.7	48.7	37.8
19	52.8	44.7	36.8
20	49.0	43.3	36.2
22	43.0	38.0	33.6
24	37.9	33.5	31.0
26		30.3	28.3
34		21.9	20.2
38		19.2	17.5
40		18.1	16.5
42		17.1	15.4
44		16.1	14.5
55			10.6
65			

**Pluma principal 68 m | 88°**

Radio [m]	Longitud de plumín [m]
	38 [t]
13.4	52.0
14	52.0
16	49.7
18	46.5
20	42.6
22	36.8
24	32.8
26	29.7
28	27.1
32	23.4
34	21.7
36	20.2
38	19.1
40	18.0
42	15.1

TLT 11959002. Estas tablas de cargas sirven únicamente como información. Para trabajos de elevación consultar las tablas de cargas de la cabina o el manual.

Tablas de cargas - plumín abatible (No. 2316.xx) | Contrapeso trasero 124t y contrapeso central 57t

**Pluma principal 20m | 83°**

Radio [m]	Longitud de plumín [m]							
	20	41	53	65	77	89	101	110
11.5	117.0							
18	64.7	61.6						
22	45.3	44.3	45.0					
24	39.6	37.5	37.9					
26		32.9	32.8	33.7				
30		26.5	26.1	36.5	25.1			
32		24.4	23.7	23.4	23.4	17.2		
36		20.9	19.7	19.3	19.2	16.5	12.2	
38		19.5	18.3	17.7	17.3	15.9	12.1	9.1
44		15.8	14.8	13.7	13.2	12.2	11.3	8.6
55			10.4	9.5	8.5	7.3	6.7	5.9
65				6.9	5.9	4.8	3.8	3.3
70					5.0	3.8	2.8	2.1
75					4.1	3.0	2.1	
80						2.3		

**Pluma principal 32m | 83°**

Radio [m]	Longitud de plumín [m]							
	20	41	53	65	77	89	101	113
13	109.2							
20	73.0	64.8						
24	55.5	54.0	47.3					
26	47.2	50.0	45.3					
28		45.6	43.1	32.9				
30		41.1	40.3	32.1	24.6			
34		34.4	35.2	30.2	23.8	16.7		
38		28.5	29.5	28.4	22.7	16.1	11.8	
46		20.8	21.4	21.7	20.1	14.7	10.8	7.7
55			15.5	15.7	16.0	13.0	10.0	7.0
65				11.1	11.1	10.9	8.9	6.2
80					6.2	5.7	5.4	4.4
85						4.6	4.0	3.0
90						3.4	2.9	
95							2.2	

**Pluma principal 41m | 83°**

Radio [m]	Longitud de plumín [m]							
	20	41	53	65	77	89	101	113
14	93.9							
22	61.7	56.5						
24	55.9	51.8	44.8					
26	49.9	47.2	43.3					
28		44.0	40.9	31.9				
32		37.5	35.5	30.7	23.3			
36		32.1	31.0	28.2	22.5	16.1		
38		29.4	28.8	27.1	22.0	15.8	11.4	
46		21.8	21.6	21.5	19.7	14.5	10.7	7.5
55			15.8	16.0	15.9	12.9	9.7	6.8
70				9.6	9.4	9.1	8.2	5.5
80					6.6	5.9	5.6	4.6
85						4.8	4.2	3.2
90						3.7	3.2	
95							2.4	

**Pluma principal 56m | 83°**

Radio [m]	Longitud de plumín [m]							
	20	41	53	65	77	89	101	113
15.9	75.6							
22	56.8	47.9						
26	48.4	42.4	38.1					
28	44.4	38.9	36.3					
30		36.4	33.8	28.8				
34		31.8	29.6	27.0	20.9			
38		27.9	26.4	24.2	20.3	14.8		
40		25.9	24.9	23.0	19.8	14.6	10.5	
44		22.9	22.5	20.8	18.3	14.0	10.2	7.2
48		19.9	19.5	18.7	17.1	13.2	9.9	7.0
60			13.1	13.1	12.8	10.8	8.6	6.1
70				9.7	9.1	8.4	7.3	5.2
80					6.6	5.7	5.3	4.2
90						3.7	3.1	2.2
95						2.8	2.4	

**Pluma principal 59m | 83°**

Radio [m]	Longitud de plumín [m]							
	20	41	53	65	77	89	101	104
16.2	71.7							
24	50.9	44.7						
26	47.0	41.5	36.7					
28	43.4	38.2	35.5					
30		35.7	33.0	28.2				
34		31.2	28.9	26.4	20.6			
38		27.6	25.8	23.6	20.0	14.3		
40		25.8	24.3	22.4	19.5	14.2	10.3	
42		24.1	23.1	21.4	18.7	14.0	10.3	9.6
46		21.3	20.6	19.2	17.2	13.3	10.0	9.4
48		19.8	19.3	18.3	16.6	12.9	9.8	9.2
60			13.2	12.9	12.5	10.4	8.5	8.0
70				9.6	9.1	8.2	7.0	6.6
80					6.6	5.6	5.1	5.1
95						2.7	2.3	2.2

**Pluma principal 65m | 83°**

Radio [m]	Longitud de plumín [m]		
	20	41	53
17	63.3		
24	48.0	41.7	
26	44.5	39.0	
28	41.7	36.2	33.0
30	38.7	33.7	31.0
32		31.6	29.0
34		29.5	27.1
36		27.8	25.6
38		26.3	24.2
40		24.7	22.8
42		23.2	21.6
46		20.7	19.5
48		19.3	18.3
50		18.0	17.1
60			12.7

**Pluma principal 68m | 83°**

Radio [m]	Longitud de plumín [m]
	38
22.6	42.5
24	41.6
26	38.6
28	35.7
30	33.6
32	31.2
34	29.2
36	27.6
38	26.0
40	24.5
42	23.3
44	21.9
46	20.4
48	15.1

TLT 11959002. Estas tablas de cargas sirven únicamente como información. Para trabajos de elevación consultar las tablas de cargas de la cabina o el manual.

Tablas de cargas - plumín abatible (No. 2316.xx) | Contrapeso trasero 124 t y contrapeso central 57 t

**Pluma principal 20 m | 75°**

Radio [m]	Longitud de plumín [m]							
	20	41	53	65	77	89	101	110
18	85.3							
26	43.8	44.9						
32		30.2	32.0					
36		25.1	25.3	24.9				
42		19.9	19.1	19.4	18.8			
44		18.5	17.8	17.7	18.0			
46		17.1	16.5	16.2	16.3	14.0		
48		15.1	15.4	14.9	15.1	13.9		
50			14.5	13.9	14.1	13.0		
55			12.3	11.6	11.1	11.2	9.8	7.5
60				9.8	9.2	8.6	8.4	7.2
70				6.8	6.4	5.4	4.8	4.7
75					5.3	4.2	3.6	3.2
80					4.2	3.2	2.5	2.1
85						2.5		

**Pluma principal 32 m | 75°**

Radio [m]	Longitud de plumín [m]							
	20	41	53	65	77	89	101	113
20	70.1							
30	45.6	43.0						
34		37.6	34.5					
40		31.0	30.0	27.3				
44		27.5	26.7	24.9	20.7			
50		23.4	22.7	21.6	19.9	14.7		
55			20.0	19.2	17.8	14.1	10.0	
60			17.7	17.0	16.0	13.3	9.8	6.7
70				13.5	12.8	11.4	9.0	6.2
80					10.0	9.0	7.9	5.5
85					8.8	7.8	6.8	5.0
90						6.8	5.8	3.4
95						5.8	4.9	
100							4.0	
105							3.3	

**Pluma principal 41 m | 75°**

Radio [m]	Longitud de plumín [m]							
	20	41	53	65	77	89	101	113
22.3	58.6							
32	40.9	37.4						
38		31.2	29.2					
40		29.8	27.6					
42		28.1	26.3	23.7				
48		23.7	22.7	21.0	18.7			
50		22.5	21.7	19.9	18.1			
55			19.1	17.9	16.2	13.7		
60			17.0	16.1	14.4	12.4	9.7	
65			14.8	14.4	13.1	11.2	9.3	6.4
75				11.4	10.4	9.2	7.7	5.8
85					8.0	7.0	5.9	4.7
90						6.0	4.9	3.9
95						5.1	4.1	2.5
105							2.6	

**Pluma principal 56 m | 75°**

Radio [m]	Longitud de plumín [m]							
	20	41	53	65	77	89	101	113
26.2	44.7							
36	32.4	28.7						
42		24.4	22.5					
44		23.5	21.5					
46		22.4	20.6	18.3				
50		20.4	18.6	16.8				
55		18.2	16.7	15.0	13.1			
60			15.1	13.5	11.7	9.9		
65			13.7	12.2	10.5	8.8	7.0	
70				11.0	9.5	7.8	6.1	4.4
80				8.5	7.5	6.3	4.7	3.1
85					6.4	5.3	4.1	2.5
90					5.5	4.4	3.3	2.1
95						3.7	2.6	
100						2.9		

**Pluma principal 59 m | 75°**

Radio [m]	Longitud de plumín [m]							
	20	41	53	65	77	89	101	104
28	40.7							
36	31.7	27.3						
42		23.6	21.6					
46		21.7	19.9	17.3				
48		20.7	18.9	17.1				
50		19.8	18.0	16.3				
55		17.9	16.2	14.6	12.8			
60			14.7	13.2	11.5	9.5		
65			13.2	11.9	10.3	8.4	7.1	6.6
70				10.6	9.3	7.5	6.3	6.0
75				9.3	8.2	6.8	5.5	5.2
80				8.1	7.1	6.0	4.8	4.5
90					5.2	4.1	3.0	2.8
95						3.3	2.3	2.1
100						2.6		

**Pluma principal 65 m | 75°**

Radio [m]	Longitud de plumín [m]		
	20	41	53
28.5	36.8		
30	35.4		
32	33.4		
34	31.6		
36	30.0		
38	28.6	24.3	
40		23.2	
42		22.0	
44		20.9	19.0
46		20.0	18.1
48		19.1	17.4
50		18.3	16.6
55		16.7	14.9
65			12.3
70			10.9

**Pluma principal 68 m | 75°**

Radio [m]	Longitud de plumín [m]
	38
28.5	24.4
38	24.2
40	22.8
42	21.6
44	20.6
46	19.7
48	18.9
50	18.1
55	16.5

TLT 11959002. Estas tablas de cargas sirven únicamente como información. Para trabajos de elevación consultar las tablas de cargas de la cabina o el manual.



Por favor contáctenos.



Descarguen la ficha técnica

**Liebherr-Werk Nenzing GmbH**

Dr. Hans Liebherr Str. 1, 6710 Nenzing/Austria  
Tel.: +43 50809 41-473, Fax: +43 50809 41-499  
crawler.crane@liebherr.com, www.liebherr.com  
facebook.com/LiebherrConstruction