

**Technical data**  
**Hydraulic lift crane**

**LR 1100**  
Litronic®



**LIEBHERR**

# Dimensions

## Basic machine with undercarriage

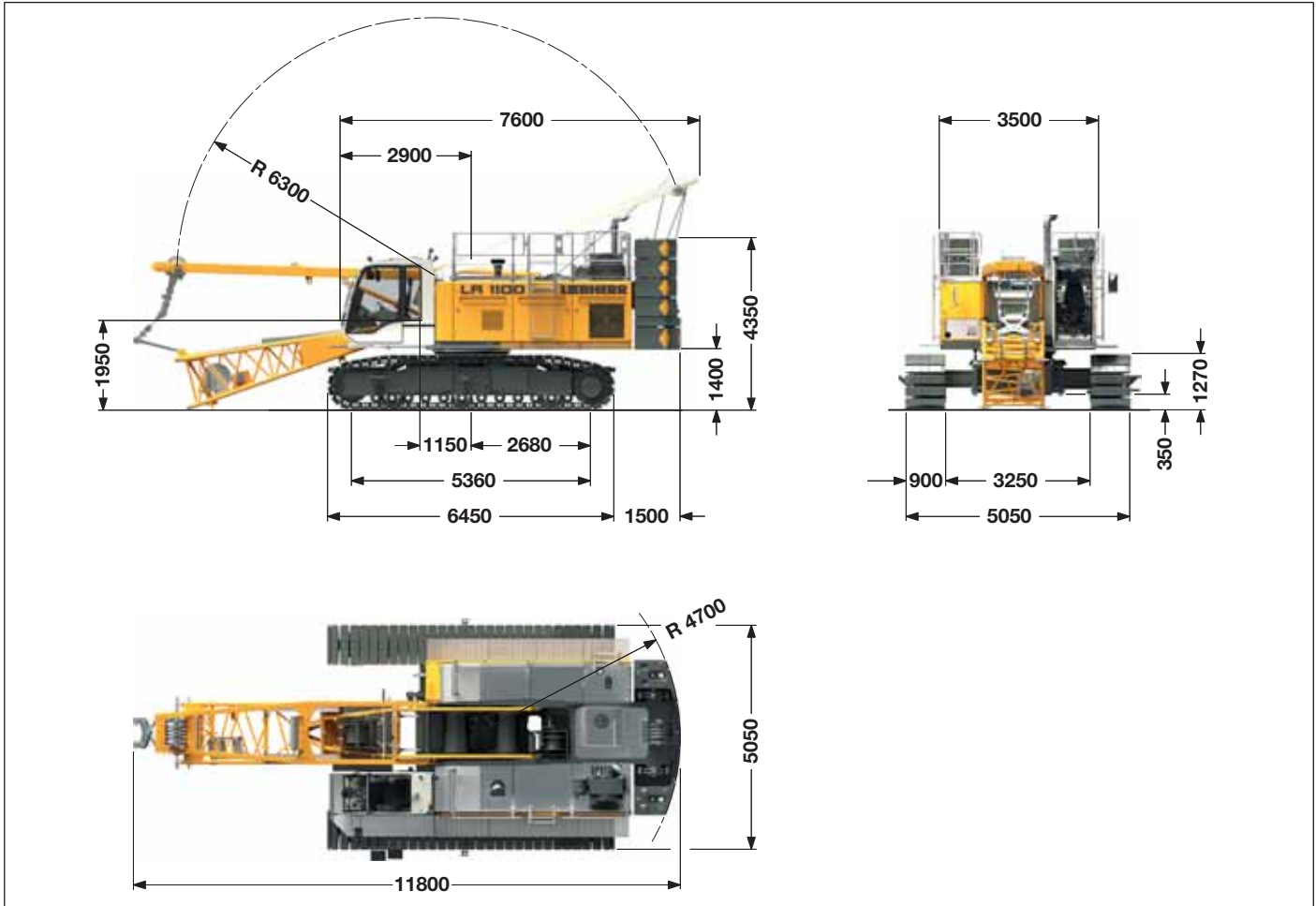

## Operating weight

The operating weight includes the basic machine with crawlers, 2 main winches 120 kN and 14 m main boom, consisting of A-frame, boom foot (5.5 m), boom head (8.5 m), 32.3 t basic counterweight, 15 t carbody counterweight and 100 t hook block.

Total weight \_\_\_\_\_ approx. 109.8 t

## Ground pressure

Ground bearing pressure \_\_\_\_\_ 1.14 kg/cm<sup>2</sup>

## Equipment

Main boom (No. 1311.xx) max. length \_\_\_\_\_ 68 m  
 High reach (No. 1311.xx and 1008.xx) max. length \_\_\_\_\_ 83 m  
 Luffing jib (No. 1008.xx) max. length \_\_\_\_\_ 62 m  
 Max. combination \_\_\_\_\_ main boom 38 m  
 \_\_\_\_\_ luffing jib 62 m  
 Fixed jib (No. 0806.xx) \_\_\_\_\_ 11 m - 32 m  
 Auxiliary jib 24 t lifting capacity (option 36 t)

## Remarks

1. The lifting capacities stated are valid for lifting operation only (corresponding with crane classification according to F.E.M. 1.001. crane group A1).
2. Crane standing on firm, horizontal ground.
3. The weight of the lifting device (hoisting ropes, hook block, shackle etc.) must be deducted from the gross lifting capacity to obtain a net lifting value.
4. Additional equipment on boom (e.g. boom walkways, auxiliary jib) must be deducted to get the net lifting capacity.
5. For max. wind speed please refer to lift chart in operator's cab or manual.
6. Working radii are measured from center of swing and under load.
7. The lifting capacities are valid for 360 degrees of swing.
8. Calculation of stability under load is based on DIN 15019 / part 2 / chart 1 and ISO 4305 Table 1 + 2, tipping angle 4°.
9. The structures are calculated according to F.E.M. 1.001 - 1998 (EN 13001-1; EN 13001-2).

# Transport dimensions and weights

## Basic machine and boom (No. 1311.xx)

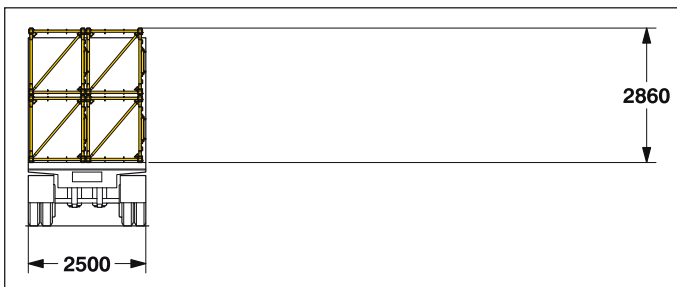
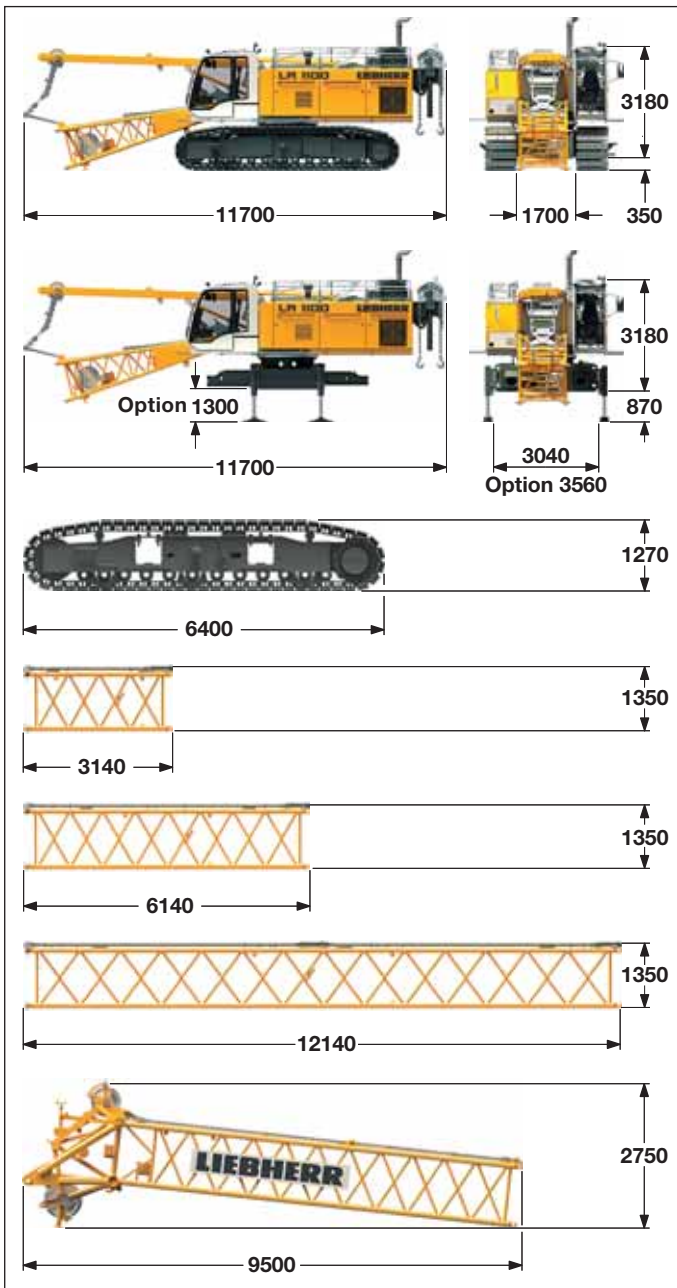

1) Pendant straps for main boom • 2) Pendant straps for jib

### Basic machine

with undercarriage, boom foot (No. 1311.22), A-frame, 2x 120 kN crane winches without wire ropes and basic counterweight	
Width	3500 mm
Weight	56200 kg
Weight of wire rope	3.42 kg/m

### Basic machine

with boom foot (No. 1311.22), A-frame, 2x 120 kN crane winches without wire ropes, basic counterweight and crawlers	
Width	3500 mm
Weight	35800 kg
Weight of wire rope	3.42 kg/m

### Crawler

**2x**

Track pads	900 mm
Width	915 mm
Weight	10200 kg

### Boom section (No. 1311.22)

**3 m**

Width	1400 mm
Weight with HPT <sup>1)</sup>	465 kg
Weight with HPT <sup>1)</sup> and NDL <sup>2)</sup>	530 kg

### Boom section (No. 1311.22)

**6 m**

Width	1400 mm
Weight with HPT <sup>1)</sup>	780 kg
Weight with HPT <sup>1)</sup> and NDL <sup>2)</sup>	890 kg

### Boom section (No. 1311.21)

**12 m**

Width	1400 mm
Weight with HPT <sup>1)</sup>	1320 kg
Weight with HPT <sup>1)</sup> and NDL <sup>2)</sup>	1550 kg

### Boom head (No. 1311.21)

Width	1650 mm
Weight with HPT <sup>1)</sup>	2300 kg

### Boom transport option (without pendant straps)

Length	12140 mm
Weight	6200 kg

# Transport dimensions and weights

## Luffing jib (No. 1008.xx)

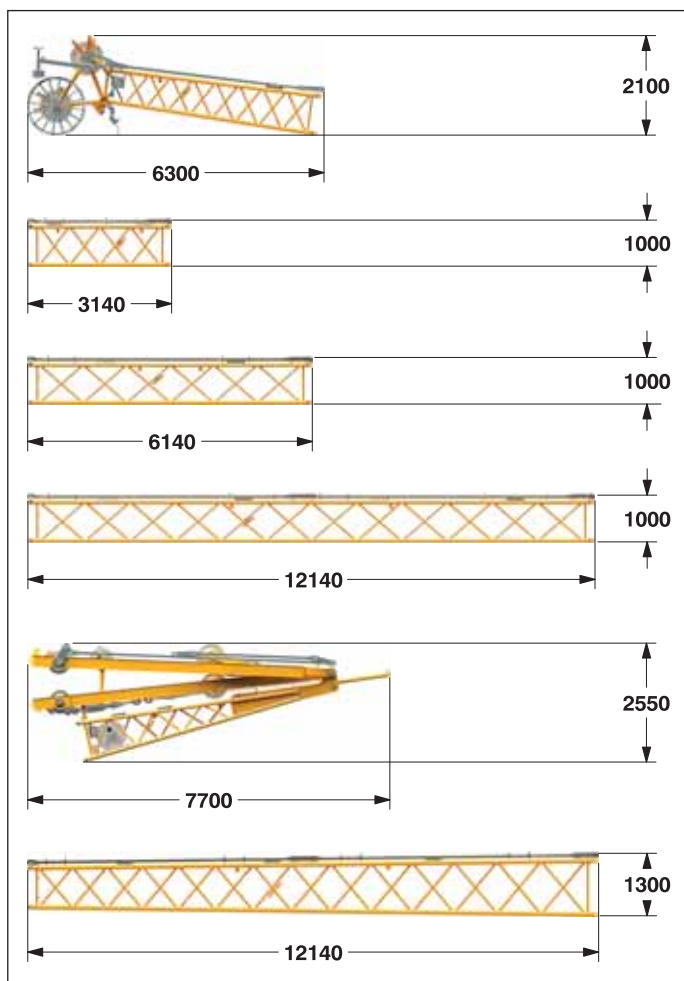

### Luffing jib head (No. 1008.17)

Width	1100 mm
Weight*	1020 kg

### Luffing jib section (No. 1008.17) 3 m

Width	1100 mm
Weight*	300 kg

### Luffing jib section (No. 1008.17) 6 m

Width	1100 mm
Weight*	455 kg

### Luffing jib section (No. 1008.17) 12 m

Width	1100 mm
Weight*	850 kg

### Luffing jib foot with A-frames (No. 1008.20)

Width	1650 mm
Weight*	3650 kg

### Boom section tapered (No. 1311/1008.21) 12 m

Width	1400 mm
Weight*	1205 kg

## Fixed jib (No. 0806.xx)

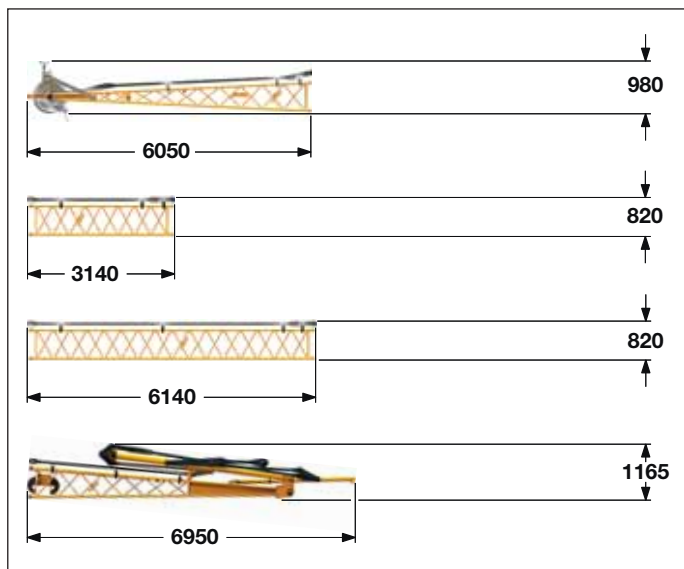

### Fixed jib head (No. 0806.16)

Width	950 mm
Weight*	460 kg

### Fixed jib section (No. 0806.15) 3 m

Width	950 mm
Weight*	145 kg

### Fixed jib section (No. 0806.15) 6 m

Width	950 mm
Weight*	250 kg

### Fixed jib foot with A-frame (No. 0806.16)

Width	2200 mm
Weight*	1040 kg

\*) Including pendant straps

# Transport dimensions and weights

## Luffing jib (No. 1309.xx)

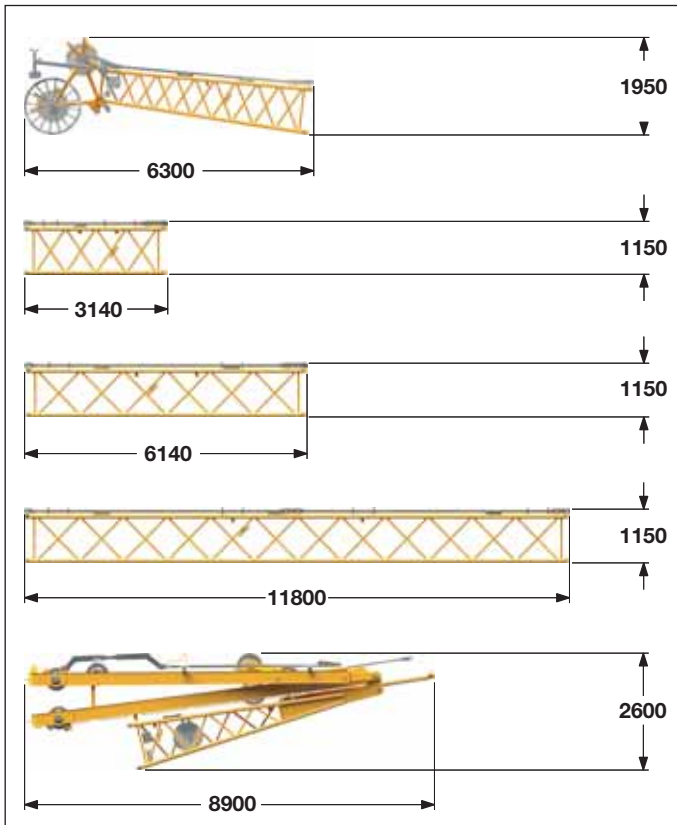

\*) Including pendant straps

### Luffing jib head (No. 1309.22)

Width	1390 mm
Weight*	1600 kg

### Luffing jib section (No. 1309.20) **3 m**

Width	1390 mm
Weight*	420 kg

### Luffing jib section (No. 1309.20) **6 m**

Width	1390 mm
Weight*	520 kg

### Luffing jib section (No. 1309.20) **11.7 m**

Width	1390 mm
Weight*	960 kg

### Luffing jib foot with A-frames (No. 1309.22)

Width	1700 mm
Weight*	4450 kg

# Transport dimensions and weights

## Counterweight

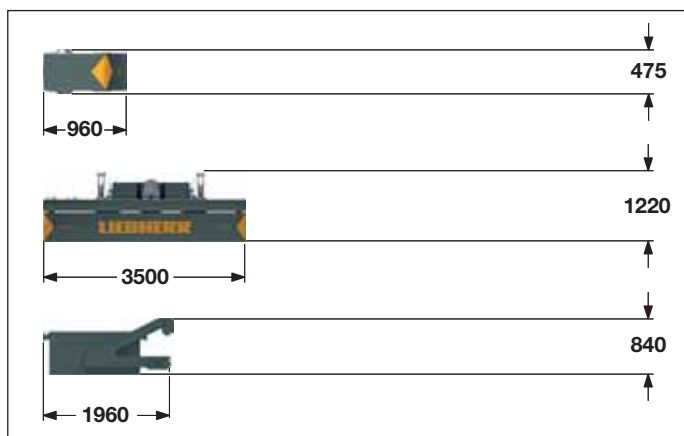

### Counterweight **10 x**

Width	850 mm
Weight	1500 kg

### Counterweight **1 x**

Width	1050 mm
Weight	17300 kg

### Carbody counterweight **2 x**

Width	1640 mm
Weight	7500 kg

## Hooks

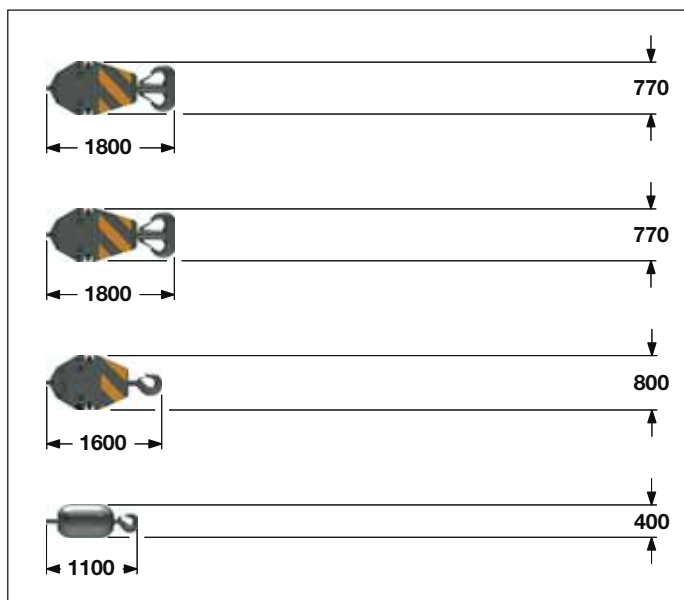

### 100 t hook block - 5 sheaves

Width	540	640	700 mm
Weight	1300	1800	2300 kg

### 80 t hook block - 3 sheaves

Width	360	460	560 mm
Weight	1000	1500	2000 kg

### 40 t hook block - 1 sheave

Width	300	400	500 mm
Weight	700	1100	1500 kg

### 12.5 t single hook

Width	400 mm
Weight	600 kg

# Technical description



## Engine

Power rating according to ISO 9249, 270 kW (362 hp) at 2000 rpm  
Engine type ———— Liebherr D 936 A7 SCR  
Fuel tank ———— 800 l capacity with continuous level indicator and reserve warning  
Engine complies with NRRM exhaust certification EPA/CARB Tier 4i or 97/68 EC Stage IIIB.



## Hydraulic system

A double axial displacement pump supplies the open loop hydraulic system, allowing all functions to be operated simultaneously. To minimize peak pressure an automatic working pressure cut-off is integrated in the pump.  
All filters are electronically monitored.  
The use of synthetic environmentally friendly (biodegradable) oils is possible.  
Working pressure ———— max. 350 bar  
Oil tank capacity ———— 650 l



## Luffing jib winch

Line pull ———— max. 105 kN  
Rope diameter ———— 20 mm  
Jib luffing ———— 46 sec. from 15° to 78°



## Boom winch

Line pull ———— max. 126 kN  
Rope diameter ———— 20 mm  
Boom up ———— 44 sec. from 15° to 86°



## Swing

Consists of rollerbearing with external teeth, swing drive with fixed axial piston hydraulic motor, spring loaded and hydraulically released multi-disc holding brake, planetary gearbox and pinion.  
Both swing modes are possible – speed control or free swing.  
A multi-disc holding brake acts automatically at zero swing motion.  
Swing speed from 0 – 1.8 rpm continuously variable.



## Main winches

Line pull (1st layer) ———— max. 175 kN  
Line pull (7th layer) ———— 120 kN  
Rope diameter ———— 26 mm  
Drum diameter ———— 580 mm  
Rope speed ———— 0 – 136 m/min  
Rope capacity in 7 layers ———— 489 m  
The winches are outstanding in their compact design and easy assembly.  
Propulsion is via a planetary gearbox in an oil bath.  
Load support by the hydraulic system; additional safety factor provided by a spring loaded, multi-disc holding brake.  
The main winches use pressure controlled, variable flow hydraulic motors. This system features sensors that automatically adjust oil flow to provide max. winch speed depending on load.  
Option – winch with freetail system:  
Clutch and braking functions on the freetail system are provided by a compact designed, low wear and maintenance free multi-disc brake.



## Crawlers

Propulsion through axial piston motor, hydraulically released spring loaded multi-disc brake, crawler tracks, hydraulic chain tensioning device.  
Track pads ———— 900 mm  
Drive speed ———— 0 – 1.35 km/h



## Control

The heart of the hydraulic crawler cranes is the Liebherr control system which has been developed and manufactured in-house.  
It includes all control and monitoring functions and is designed to withstand extreme environmental conditions and heavy duty construction tasks. Complete machine operating data as well as warning signals and irregularities are clearly displayed on the high resolution monitor in the operator's cab in the required language.  
The electro-hydraulic proportional control allows several movements to be performed simultaneously. This ensures that all categories of loads can be positioned with utmost precision.  
Option:  
• GSM/GPRS telematics module



## Noise emission

Noise emissions correspond with 2000/14/EC directive on noise emission by equipment used outdoors.



# Boom combinations



Main boom No. 1311.xx — 68 m

Max. combination — 83 m

Max. combination — 85 m

Main boom No. 1311.xx — 44.5 m

Main boom No. 1311.xx — 53 m

Tapered No. 1311/1008.xx — 12 m

Fixed jib No. 0806.xx — 32 m

Luffing jib No. 1008.xx — 26.5 m



# Boom combinations



Max. combination	—————	100 m
Main boom	No. 1311.xx	38 m
Luffing jib	No. 1008.xx	62 m
Main boom	No. 1311.xx	41 m
Luffing jib	No. 1008.xx	44 m

Max. combination	—————	101.8 m
Main boom	No. 1311.xx	35 m
Luffing jib	No. 1008.xx	66.8 m
Main boom	No. 1311.xx	38 m
Luffing jib	No. 1008.xx	46.1 m

# Self assembly system

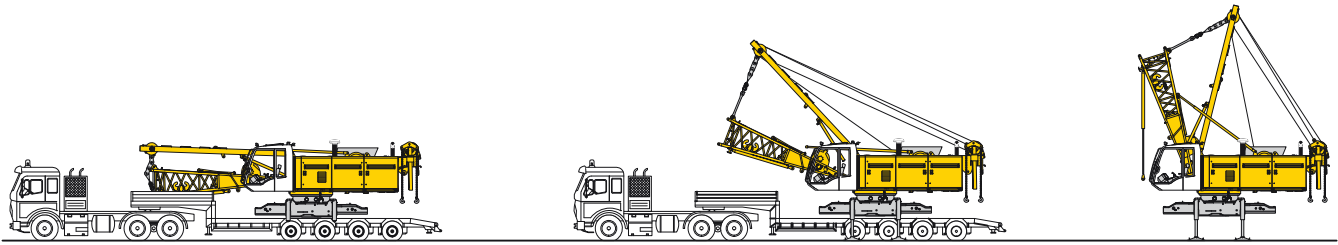

Unloading of basic machine (option)

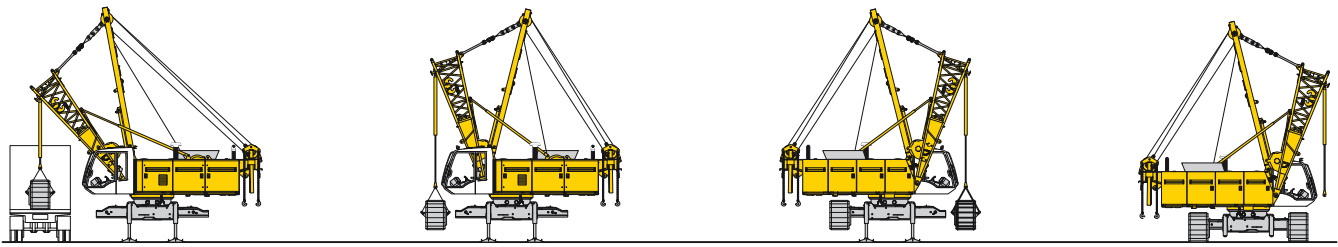

Unloading and assembly of crawlers

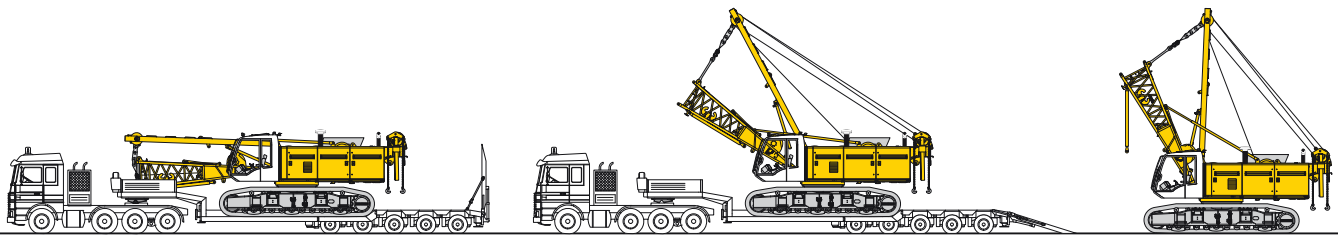

Unloading of basic machine (standard)

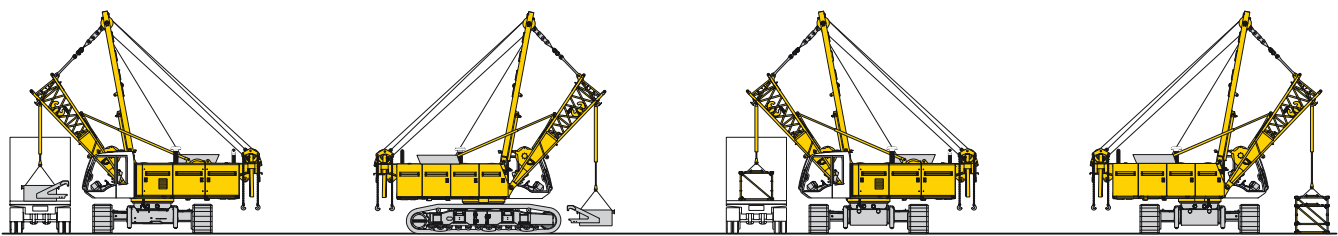

Unloading and assembly of carbody counterweight

Unloading and assembly of boom

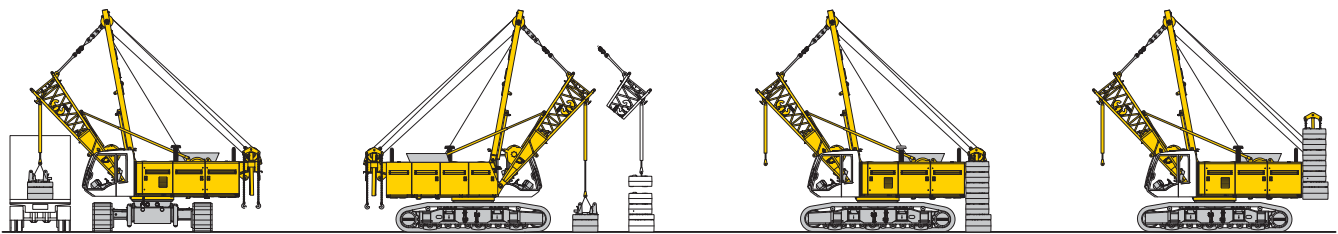

Unloading and assembly of counterweight

# Erecting of main boom to working position

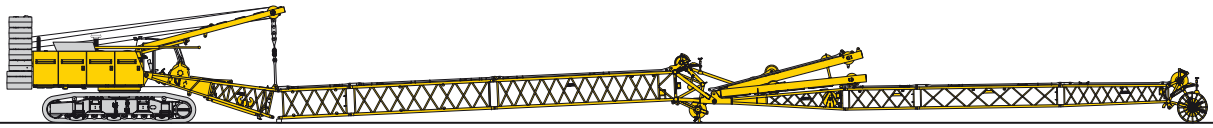

Assembly of boom

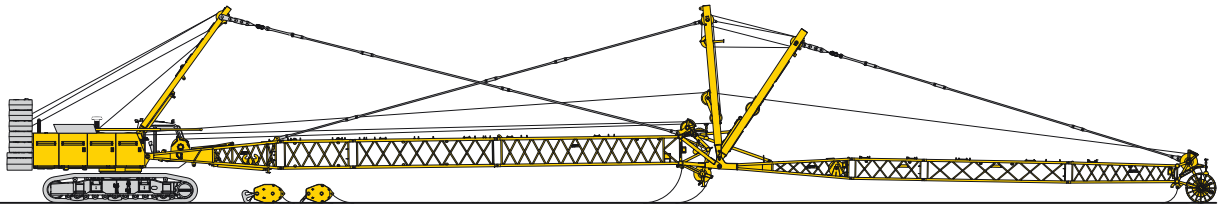

Reeving of hoist and luffing jib ropes



Erecting of main boom and luffing jib

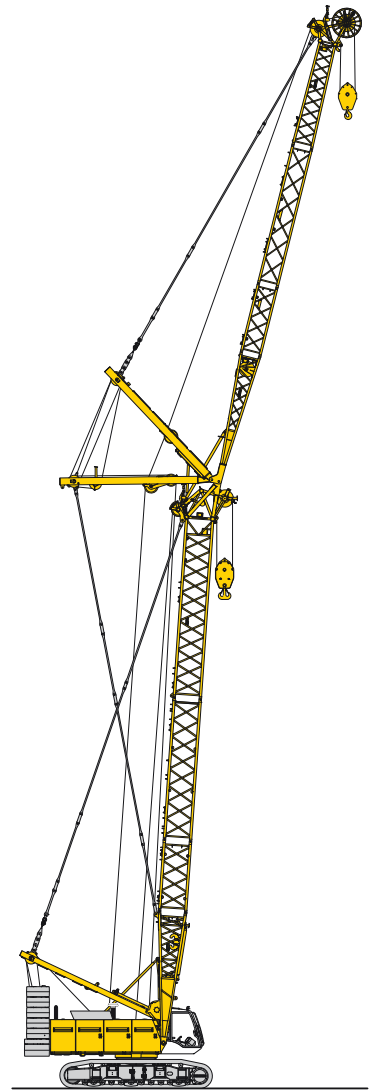

Working position

# Working range - main boom (No. 1311.xx) **86° - 15°** **32.3 t counterweight and 15 t carbody counterweight**

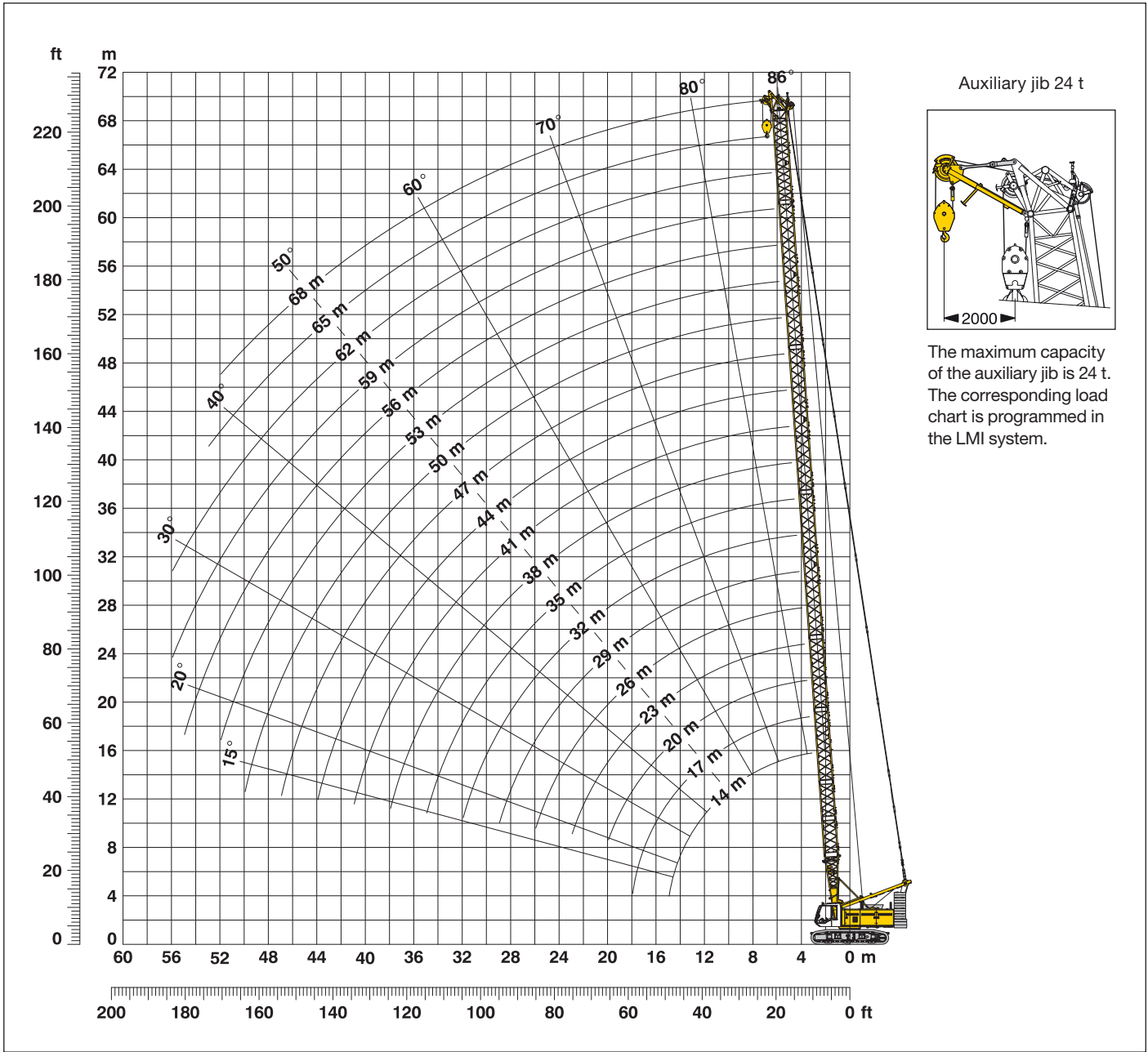

## Main boom configuration (Table 1 – No. 1311.xx)

Configuration for boom lengths (14 m - 68 m)

	Length	Amount of boom extensions																		
		1	1	1	1	1	1	1	1	1	1	1	1	1	1	1	1	1	1	
Boom foot	5.5 m	1	1	1	1	1	1	1	1	1	1	1	1	1	1	1	1	1	1	
Boom insert	3 m		1		1		1		1		1		1		1		1		1	
Boom insert	6 m			1	1	2	2	1	1	2	2	1	1	2	2	1	1	2	2	
Boom insert	12 m							1	1	1	1	2	2	2	3	3	3	3	3	
Boom head	8.5 m	1	1	1	1	1	1	1	1	1	1	1	1	1	1	1	1	1	1	
Boom length (m)		14	17	20	23	26	29	32	35	38	41	44	47	50	53	56	59	62	65	68

# Lift chart for main boom (No. 1311.xx)

Capacities in metric tonnes for boom lengths (14 m - 68 m) - with 120 kN winches  
32.3 t counterweight and 15 t carbody counterweight

Radius	Boom length in (m)										Radius
	14	20	26	32	38	44	50	56	62	68	
(m)	t	t	t	t	t	t	t	t	t	t	(m)
3.1	104.5										3.1
4	103.7	100.9	82.8								4
5	86.0	77.4	70.2	64.2	50.5						5
6	68.3	62.6	57.6	53.4	48.0	35.4	27.7	18.8			6
7	56.5	52.4	48.7	45.6	42.7	34.5	26.9	18.6	15.2	11.7	7
8	46.8	45.0	42.1	39.7	37.3	33.2	26.2	18.2	14.8	11.5	8
9	39.5	39.3	37.0	35.0	33.1	31.4	25.2	17.9	14.6	11.3	9
10	34.1	34.2	33.0	31.3	29.7	28.2	24.5	17.5	14.2	11.1	10
12	26.6	26.7	26.6	25.7	24.4	23.3	22.2	16.9	13.5	10.5	12
14	21.6	21.7	21.6	21.5	20.6	19.7	18.8	15.9	12.9	10.1	14
16		18.1	18.0	18.0	17.7	16.9	16.1	15.0	12.1	9.6	16
18		15.5	15.4	15.3	15.1	14.8	14.1	13.4	11.4	9.1	18
20		13.3	13.3	13.2	13.0	12.9	12.4	11.8	10.9	8.7	20
22			11.7	11.6	11.4	11.3	11.0	10.5	9.8	8.3	22
24			10.3	10.3	10.1	9.9	9.7	9.3	8.8	7.8	24
26			9.1	9.1	8.9	8.8	8.5	8.3	7.8	7.2	26
28				8.2	8.0	7.8	7.6	7.4	7.0	6.5	28
30				7.3	7.1	7.0	6.7	6.6	6.3	5.8	30
32				6.6	6.4	6.3	6.0	5.8	5.6	5.1	32
34					5.8	5.6	5.4	5.2	5.0	4.6	34
36					5.2	5.1	4.8	4.7	4.4	4.1	36
38					4.7	4.6	4.4	4.2	3.9	3.6	38
40						4.1	3.9	3.7	3.5	3.2	40
42						3.7	3.5	3.3	3.1	2.8	42
44						3.3	3.1	3.0	2.7	2.4	44
46							2.8	2.6	2.4	2.1	46
48								2.5	2.3	2.1	48
50								2.2	2.0		50

TLT 9834997 M 103673

Above lift chart is for reference only. For actual lift duty please refer to lift chart in operator's cab or manual.

# L-boom high reach (No. 1311/1008.xx) 50 m - 83 m

Working range 86° - 15°

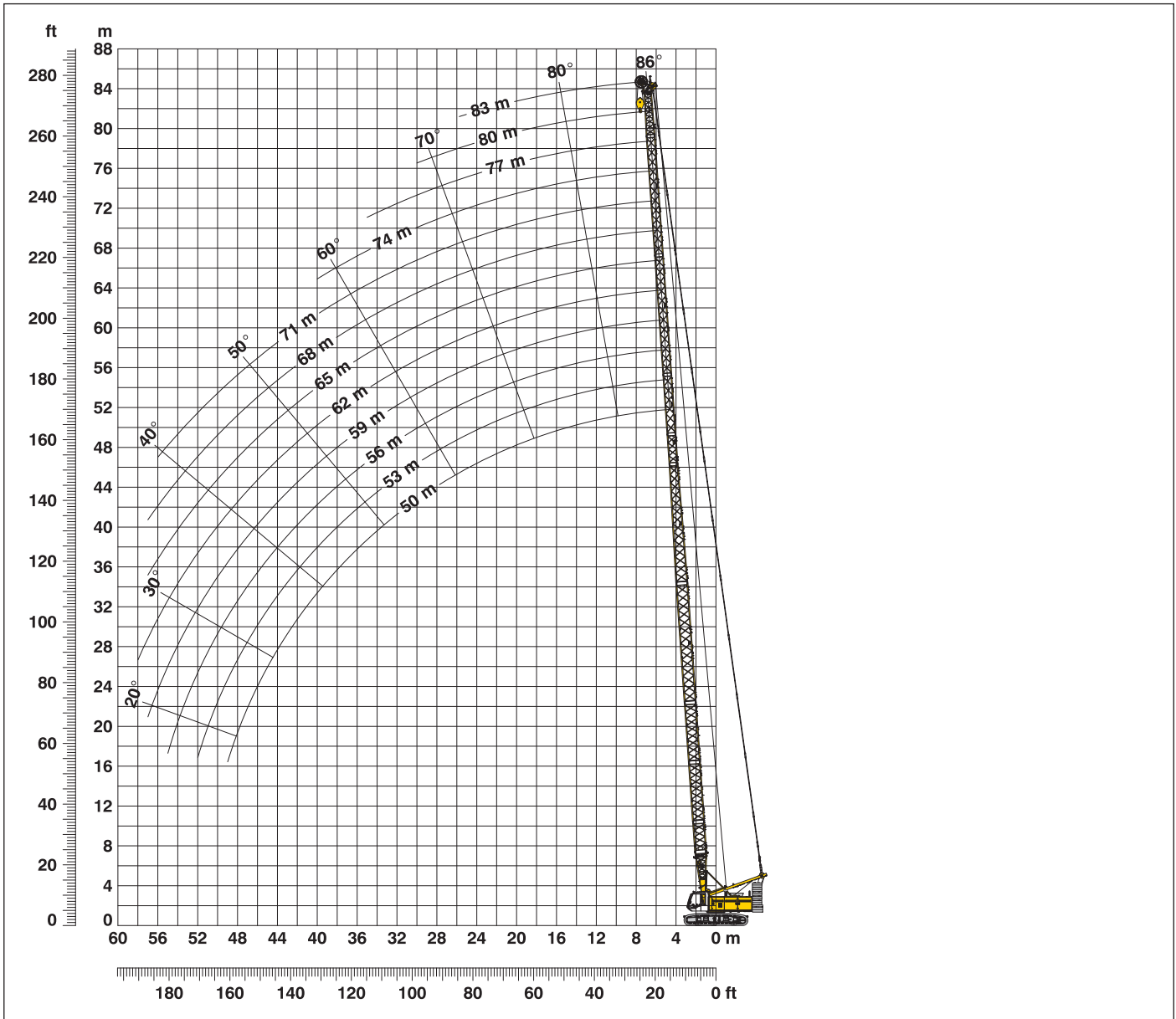

## L-boom configuration with 32.5 m main boom (No. 1311.xx/1008.xx)

Configuration for L-boom lengths (50 m - 83 m)

	Length	Amount of boom and luffing jib extensions											
		50	53	56	59	62	65	68	71	74	77	80	83
Boom foot	5.5 m	1	1	1	1	1	1	1	1	1	1	1	1
Boom insert	3 m	1	1	1	1	1	1	1	1	1	1	1	1
Boom insert	6 m	2	2	2	2	2	2	2	2	2	2	2	2
Boom insert	12 m	1	1	1	1	1	1	1	1	1	1	1	1
Tapered	12 m	1	1	1	1	1	1	1	1	1	1	1	1
Luffing insert	3 m		1		1		1		1		1		1
Luffing insert	6 m			1	1			1	1			1	1
Luffing insert	12 m					1	1	1	1	2	2	2	2
Luffing jib head	5.5 m	1	1	1	1	1	1	1	1	1	1	1	1
Max. L-boom length (m)		50	53	56	59	62	65	68	71	74	77	80	83

# Lift chart for L-boom (No. 1311/1008.xx)

## Main boom length 32.5 m

Capacities in metric tonnes 32.3 t counterweight and 15 t carbody counterweight				
Radius	L-boom length in (m)			
	50	62	74	83
(m)	t	t	t	t
5.2	27.0			
6	26.6			
7	25.5	12.8	7.1	
8	24.5	12.2	6.8	4.5
9	23.4	11.7	6.5	4.4
10	22.6	11.2	6.2	4.2
12	20.8	10.4	5.7	3.8
14	19.2	9.6	5.2	3.4
16	17.0	8.9	4.7	3.1
18	14.9	8.3	4.4	2.9
20	13.2	7.8	4.0	2.6
22	11.8	7.3	3.8	2.4
24	10.4	6.9	3.5	2.2
26	9.3	6.5	3.3	2.1
28	8.4	6.1	3.0	
30	7.5	5.7	2.9	
32	6.8	5.5	2.6	
34	6.2	5.2	2.4	
36	5.6	5.0	2.3	
38	5.2	4.8	2.1	
40	4.7	4.5	2.0	
42	4.3	4.1		
44	4.0	3.8		
46	3.6	3.5		
48	3.3	3.2		
50		2.9		
4.5		2.3		

TLT 9834997 M 103673

## Main boom length 44.5 m

Capacities in metric tonnes 32.3 t counterweight and 15 t carbody counterweight				
Radius	L-boom length in (m)			
	62	68	74	83
(m)	t	t	t	t
6.1	16.1			
7	15.8	11.9	9.1	
8	15.1	11.5	8.9	6.0
9	14.5	11.2	8.5	5.7
10	13.8	10.9	8.2	5.5
12	12.8	10.2	7.6	5.1
14	11.8	9.4	7.1	4.7
16	11.1	8.7	6.5	4.3
18	10.4	8.0	6.2	4.0
20	9.9	7.4	5.7	3.7
22	9.3	6.9	5.4	3.4
24	8.8	6.4	5.1	3.2
26	8.5	5.9	4.8	3.0
28	7.8	5.6	4.5	2.8
30	7.1	5.4	4.3	2.6
32	6.4	5.2	4.1	2.5
34	5.8	5.0	3.8	2.3
36	5.2	4.7	3.6	2.2
38	4.7	4.4	3.5	2.0
40	4.3	4.1	3.3	
42	3.9	3.7	3.2	
44	3.5	3.4	3.0	
46	3.2	3.1	2.9	
48	2.9	2.8	2.7	
50	2.6	2.5	2.4	
55	2.0			

TLT 9834997 M 103673

Above lift chart is for reference only. For actual lift duty please refer to lift chart in operator's cab or manual.

## L-boom configuration with 44.5 m main boom (No. 1311.xx/1008.xx)

Configuration for L-boom lengths (62 m - 83 m)									
	Length	Amount of boom and luffing jib extensions							
Boom foot	5.5 m	1	1	1	1	1	1	1	1
Boom insert	3 m	1	1	1	1	1	1	1	1
Boom insert	6 m	2	2	2	2	2	2	2	2
Boom insert	12 m	2	2	2	2	2	2	2	2
Tapered	12 m	1	1	1	1	1	1	1	1
Luffing insert	3 m		1		1		1		1
Luffing insert	6 m			1	1			1	1
Luffing insert	12 m					1	1	1	1
Luffing jib head	5.5 m	1	1	1	1	1	1	1	1
Max. L-boom length (m)		62	65	68	71	74	77	80	83



# Working range - luffing jib (No. 1008.xx) 78° - 15°

Main boom 88° - 45°

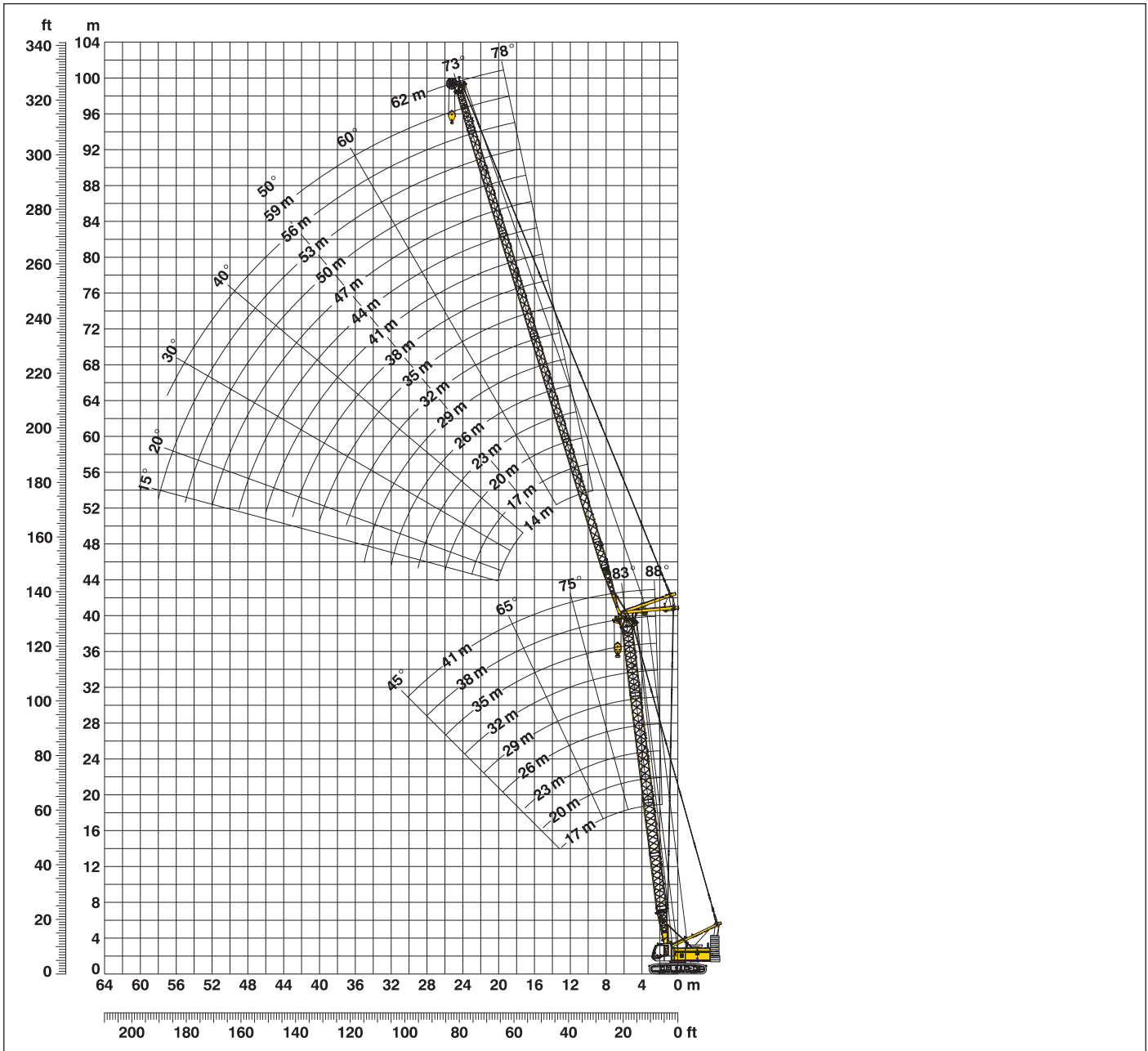

**Boom configuration for main boom lengths (17 m - 41 m)** – see table 1 on page 12

**Jib configuration for jib lengths (14 m - 62 m)**

	Length	Amount of luffing jib extensions																	
Luffing jib foot	5.5 m	1	1	1	1	1	1	1	1	1	1	1	1	1	1	1	1	1	1
Luffing jib insert	3 m	1		1		1		1		1		1		1		1		1	
Luffing jib insert	6 m		1	1			1		1		1		1		1		1	2	2
Luffing jib insert	12 m				1	1	1		1	2	2	2	2	3	3	3	3	3	3
Luffing jib head	5.5 m	1	1	1	1	1	1	1	1	1	1	1	1	1	1	1	1	1	1
Luffing jib length in (m)		14	17	20	23	26	29	32	35	38	41	44	47	50	53	56	59	62	

# Lift chart - luffing jib (No. 1008.xx)

## Main boom 88°

### Main boom 17 m

Radius (m)	Jib length in (m)							
	14	23	29	35	44	50	56	62
5.9	47.3							
8	41.8	27.9						
10	33.5	25.3	18.4					
11	30.5	24.0	17.7	13.3				
13	25.8	21.1	16.4	12.7	8.3			
14	23.7	20.1	15.7	12.4	8.1	6.0		
15	21.7	18.8	15.0	12.2	7.9	5.9	4.6	
16	17.0	17.6	14.5	11.9	7.7	5.7	4.5	3.3
20		14.0	12.1	10.9	7.0	5.2	4.1	2.9
24		10.6	10.4	9.8	6.6	4.7	3.7	2.6
30			7.3	8.6	6.2	4.3	3.4	2.3
36				5.8	5.9	4.0	3.1	2.0
44					4.3	3.7	2.9	
50						3.2	2.7	
55							2.5	

### Main boom 23 m

Radius (m)	Jib length in (m)							
	14	23	29	35	44	50	56	62
6.1	42.1							
8	37.1	24.9						
10	31.8	23.1	16.9					
11	29.0	22.0	16.4	12.3				
13	24.6	19.9	15.3	11.8	7.8			
14	22.9	19.1	14.7	11.5	7.6	5.7		
16	18.8	17.1	13.7	11.0	7.3	5.4	4.3	
18		15.7	12.7	10.6	7.0	5.1	4.1	3.0
24		11.1	10.0	9.4	6.2	4.5	3.6	2.5
30			7.6	7.8	5.9	4.1	3.3	2.2
34				6.8	5.7	3.9	3.1	2.0
36				6.2	5.6	3.9	3.0	
44					4.5	3.6	2.8	
50						3.4	2.6	
55							2.5	

### Main boom 29 m

Radius (m)	Jib length in (m)							
	14	23	29	35	44	50	56	62
6.3	33.8							
9	29.0	20.9						
10	27.6	20.0	15.1					
11	25.8	19.2	14.7	11.1				
13	23.1	17.7	13.8	10.7	7.2			
14	21.7	17.1	13.4	10.5	7.1	5.3		
16	18.8	15.6	12.6	10.1	6.8	5.1	4.0	
18		14.4	11.8	9.7	6.5	4.8	3.8	2.8
24		10.7	9.4	8.6	5.9	4.3	3.4	2.4
30			7.5	7.1	5.5	3.9	3.1	2.1
32				6.7	5.4	3.8	3.0	2.0
36				6.0	5.0	3.7	2.9	
44					4.3	3.5	2.7	
50						3.2	2.5	
55							2.3	

### Main boom 35 m

Radius (m)	Jib length in (m)							
	14	23	29	35	44	50	56	62
6.5	24.9							
9	21.9	16.5						
10	20.7	15.9	12.5					
11	19.6	15.2	12.2	9.6				
13	17.8	14.0	11.4	9.3	6.4			
15	16.2	13.1	10.7	8.9	6.2	4.7		
16	15.5	12.6	10.3	8.7	6.1	4.6	3.7	
17	9.3	12.2	10.1	8.4	6.0	4.5	3.6	2.6
24		8.9	7.8	7.0	5.3	3.9	3.1	2.2
26			7.2	6.6	5.1	3.8	3.0	2.1
30			6.4	5.8	4.9	3.6	2.8	
36				4.9	4.1	3.4	2.7	
46					3.1	2.7	2.2	
48						2.6	2.1	
50							2.4	

### Main boom 38 m

Radius (m)	Jib length in (m)							
	14	23	29	35	44	50	56	62
6.7	21.6							
9	19.2	14.6						
10	18.3	14.2	11.4					
12	16.3	13.0	10.9	8.9				
13	15.5	12.5	10.5	8.7	6.0			
15	14.0	11.7	9.9	8.3	5.8	4.5		
16	13.6	11.2	9.6	8.1	5.7	4.4	3.5	
17	8.3	10.8	9.3	7.8	5.6	4.3	3.4	2.4
20		9.5	8.4	7.3	5.3	4.0	3.2	2.3
24		8.2	7.3	6.5	4.9	3.7	3.0	2.1
30			6.0	5.4	4.5	3.4	2.7	
36				4.6	3.8	3.2	2.5	
44					3.0	2.6	2.1	
46					2.6	2.5		
50						2.2		

### Main boom 41 m

Radius (m)	Jib length in (m)							
	14	23	29	35	44			
6.8	19.1							
9	17.2	13.0						
10	16.5	12.8	10.3					
12	14.7	11.6	9.9	8.1				
13	13.9	11.2	9.5	8.0	5.7			
14	13.2	10.9	9.2	7.8	5.6			
16	12.4	10.1	8.7	7.4	5.4			
17	7.5	9.7	8.5	7.2	5.3			
20		8.7	7.7	6.7	5.0			
24		7.6	6.7	6.0	4.6			
28			5.9	5.3	4.3			
30			5.6	5.0	4.1			
36				4.3	3.5			
44					2.8			
46					2.3			

TLT 9834997 M 103673

Capacities in metric tonnes with luffing jib (No. 1008.xx), 32.3 t counterweight + 15 t carbody counterweight. Above lift chart is for reference only. For actual lift duty and complete chart with all available configurations please refer to lift chart in operator's cab or manual.

# Lift chart - luffing jib (No. 1008.xx)

## Main boom 83°

### Main boom 17 m

Radius (m)	Jib length in (m)							
	14	23	29	35	44	50	56	62
8.6	t	t	t	t	t	t	t	t
12	37.6	24.8						
13	27.0	23.3	17.1					
15	21.2	20.2	16.1	12.4				
17	18.0	17.8	14.8	12.0				
18		16.8	14.4	11.7	7.6			
20		14.7	13.1	11.2	7.2	5.3		
22		13.1	12.2	10.8	6.9	5.0	4.0	
24		11.7	11.2	10.3	6.7	4.8	3.8	2.7
26		10.6	10.4	9.9	6.5	4.7	3.7	2.5
32			7.1	7.9	6.2	4.3	3.4	2.3
38				5.7	6.0	4.0	3.1	2.0
46					4.4	3.7	2.9	
50						3.5	2.8	
55							2.6	

### Main boom 23 m

Radius (m)	Jib length in (m)							
	14	23	29	35	44	50	56	62
9.4	t	t	t	t	t	t	t	t
12	32.3	23.0						
14	21.8	20.4	15.7					
16	19.1	17.9	14.8	11.4				
19		15.1	13.5	10.8	7.0			
20		14.3	12.9	10.6	6.9	5.1		
22		12.9	12.0	10.3	6.7	4.8	3.8	
24		11.6	11.2	9.9	6.4	4.7	3.7	2.6
26		10.5	10.2	9.6	6.3	4.5	3.6	2.5
32			7.9	7.8	6.0	4.2	3.3	2.2
36				6.6	5.8	4.0	3.1	2.1
38				6.1	5.8	3.9	3.0	
42					5.1	3.8	2.9	
50						3.6	2.7	
55							2.6	

### Main boom 29 m

Radius (m)	Jib length in (m)							
	14	23	29	35	44	50	56	62
10.1	t	t	t	t	t	t	t	t
13	28.0	20.1						
15	19.2	18.0	13.9					
17	16.9	15.9	13.2	10.3				
19	15.2	14.3	12.5	10.0	6.6			
22		12.3	11.4	9.5	6.3	4.6		
24		11.3	10.8	9.2	6.1	4.4	3.5	
26		10.3	9.9	8.9	5.9	4.3	3.4	2.4
28		8.0	9.1	8.7	5.8	4.2	3.3	2.3
32			7.7	7.5	5.7	4.0	3.1	2.1
34				7.0	5.6	3.9	3.1	2.0
38				6.0	5.4	3.8	2.9	
48					3.5	3.5	2.7	
50						3.5	2.7	
60							2.1	

### Main boom 35 m

Radius (m)	Jib length in (m)							
	14	23	29	35	44	50	56	62
10.8	t	t	t	t	t	t	t	t
14	22.6	15.1						
16	19.3	14.1	11.4					
17	16.0	13.6	11.1	8.9				
20	10.1	12.3	10.2	8.5	5.9			
22		11.6	9.6	8.1	5.7	4.3		
24		10.7	9.1	7.8	5.6	4.1	3.2	
26		9.8	8.7	7.4	5.4	4.0	3.1	2.2
28		9.1	8.3	7.2	5.3	3.9	3.0	2.1
32			7.5	6.7	5.1	3.7	2.9	
34			7.0	6.5	5.1	3.6	2.8	
40				4.3	4.7	3.4	2.7	
48					3.9	3.2	2.5	
50						3.1	2.4	
60							2.1	

### Main boom 38 m

Radius (m)	Jib length in (m)							
	14	23	29	35	44	50	56	62
11.2	t	t	t	t	t	t	t	t
14	19.4	13.2						
16	17.1	12.4	10.4					
18	15.6	11.5	9.8	8.1				
20	14.5	10.7	9.2	7.7	5.5			
22	9.4	10.1	8.6	7.3	5.3	4.0		
24		9.6	8.2	7.0	5.1	3.9	3.1	
26		9.1	7.9	6.7	5.0	3.8	3.0	2.1
28		8.6	7.6	6.5	4.9	3.7	2.9	2.0
32			7.0	6.1	4.6	3.6	2.8	
34			6.6	5.9	4.5	3.5	2.7	
38				5.4	4.3	3.4	2.6	
40				5.1	4.2	3.3	2.6	
48					3.5	3.0	2.4	
55						2.5	2.1	

### Main boom 41 m

Radius (m)	Jib length in (m)							
	14	23	29	35	44			
11.6	t	t	t	t	t			
15	17.0	11.3						
16	14.5	10.9	9.2					
18	13.9	10.2	8.7	7.3				
20	13.1	9.5	8.1	6.9				
22	12.4	9.0	7.7	6.6	5.0			
24		8.6	7.3	6.3	4.8			
26		8.3	7.0	6.0	4.6			
28		7.9	6.8	5.8	4.5			
32			6.4	5.5	4.2			
34			6.1	5.3	4.1			
38				5.0	3.9			
40				4.7	3.8			
46					3.4			
48					3.3			

TLT 9834997 M 103673

Capacities in metric tonnes with luffing jib (No. 1008.xx), 32.3 t counterweight + 15 t carbody counterweight. Above lift chart is for reference only. For actual lift duty and complete chart with all available configurations please refer to lift chart in operator's cab or manual.

# Lift chart - luffing jib (No. 1008.xx)

## Main boom 75°

### Main boom 17 m

Radius (m)	Jib length in (m)							
	14	23	29	35	44	50	56	62
12.8	t	t	t	t	t	t	t	t
17	24.0							
20	17.2	16.8						
22	14.0	14.0	13.6					
26		12.4	12.2	11.0				
28		10.1	9.9	9.7	6.6			
32		9.1	9.0	8.9	6.5	4.6		
34			7.6	7.4	6.3	4.4	3.5	
36			7.0	6.9	6.2	4.3	3.3	2.3
40				6.3	6.0	4.2	3.3	2.2
44				5.4	5.2	4.0	3.1	2.0
48					4.5	3.9	3.0	
50					3.9	3.7	2.9	
55						3.5	2.9	
60						2.9	2.7	
							2.3	

### Main boom 23 m

Radius (m)	Jib length in (m)							
	14	23	29	35	44	50	56	62
14.3	t	t	t	t	t	t	t	t
19	19.6							
20	14.5	13.9						
22	13.6	13.1						
24		11.9	11.4					
28		10.7	10.4	9.9				
30		8.8	8.7	8.4	6.2			
34		8.0	7.9	7.7	6.1	4.4		
36			6.7	6.5	6.0	4.2	3.3	
40			6.2	6.0	5.7	4.1	3.2	2.1
42				5.2	4.9	3.9	3.0	2.0
46				4.8	4.6	3.9	3.0	
50					3.9	3.8	2.9	
55					3.4	3.3	2.8	
60						2.7	2.5	
							2.1	

### Main boom 29 m

Radius (m)	Jib length in (m)							
	14	23	29	35	44	50	56	62
15.9	t	t	t	t	t	t	t	t
20	16.2							
22	12.8	12.1						
24	11.6	10.9						
26		10.0	9.5					
30		9.2	8.7	8.3				
32		7.7	7.4	7.1	5.8			
34		7.0	6.9	6.5	5.7	4.1		
36			6.3	6.1	5.5	4.0	3.1	
38			5.9	5.7	5.1	3.9	3.1	
40				5.3	4.8	3.9	3.0	2.0
42				4.9	4.5	3.8	2.9	
46				4.5	4.2	3.7	2.9	
50					3.6	3.3	2.8	
55					3.2	2.9	2.6	
						2.5	2.2	

### Main boom 35 m

Radius (m)	Jib length in (m)							
	14	23	29	35	44	50	56	62
17.4	t	t	t	t	t	t	t	t
22	13.5							
24	10.7	10.0						
28	9.7	9.1	8.6					
32		7.7	7.3	6.9				
34		6.6	6.3	5.9	5.2			
36			5.8	5.5	4.9	3.7		
38			5.4	5.1	4.5	3.7	2.8	
40			5.1	4.8	4.2	3.6	2.8	
42				4.5	3.9	3.5	2.7	
44				4.2	3.7	3.3	2.7	
46				3.9	3.4	3.1	2.6	
48					3.2	2.9	2.6	
50					3.0	2.7	2.4	
55					2.8	2.5	2.2	
						2.1		

### Main boom 38 m

Radius (m)	Jib length in (m)							
	14	23	29	35	44	50	56	62
18.2	t	t	t	t	t	t	t	t
22	12.3							
24	10.2	9.5						
26	9.3	8.7						
28		7.9	7.5					
32		7.3	6.9	6.4				
34		6.3	5.9	5.5	4.5			
36		5.9	5.5	5.2	4.4	3.5		
38			5.1	4.8	4.2	3.5	2.6	
40			4.8	4.5	3.9	3.4	2.6	
42			4.5	4.2	3.7	3.3	2.6	
44				3.9	3.4	3.1	2.6	
46				3.7	3.2	2.9	2.5	
48				3.4	3.0	2.7	2.3	
50					2.8	2.5	2.2	
					2.6	2.3		

### Main boom 41 m

Radius (m)	Jib length in (m)							
	14	23	29	35	44			
19	t	t	t	t	t			
24	11.2							
26	8.8	8.1						
28	8.0	7.5	6.7					
30		6.9	6.4	5.5				
32		6.4	6.0	5.4				
34		5.9	5.5	5.2	3.9			
36		5.5	5.2	4.8	3.9			
38			4.8	4.5	3.8			
40			4.5	4.2	3.6			
42			4.2	3.9	3.4			
44				3.6	3.1			
46				3.4	2.9			
48				3.2	2.7			
50					2.5			
					2.3			

TLT 9834997 M 103673

Capacities in metric tonnes with luffing jib (No. 1008.xx), 32.3 t counterweight + 15 t carbody counterweight. Above lift chart is for reference only. For actual lift duty and complete chart with all available configurations please refer to lift chart in operator's cab or manual.

# Lift chart - luffing jib (No. 1008.xx)

## Main boom 65°

### Main boom 17 m

Radius (m)	Jib length in (m)						
	14	23	29	35	44	50	56
17.6	t	t	t	t	t	t	t
22	15.5						
24	11.7						
28		10.4					
30		8.5	8.3				
36		7.8	7.6	7.4			
40			5.9	5.8	5.5		
42				5.0	4.7	4.0	
46				4.6	4.4	3.9	3.1
50					3.8	3.6	3.0
55					3.2	3.1	2.9
						2.6	2.4

### Main boom 23 m

Radius (m)	Jib length in (m)						
	14	23	29	35	44	50	56
20.2	t	t	t	t	t	t	t
24	12.3						
26	9.9						
30		8.7					
34		7.2	7.0				
38		6.1	5.9	5.7			
40			5.1	4.9	4.5		
42			4.7	4.5	4.2		
46				4.2	3.9	3.6	
50				3.6	3.3	3.1	2.8
55					2.9	2.7	2.4
						2.2	

### Main boom 29 m

Radius (m)	Jib length in (m)					
	14	23	29	35	44	50
22.7	t	t	t	t	t	t
28	9.7					
32	7.4	7.1				
36		6.0	5.7			
40		5.1	4.9	4.6		
42			4.2	4.0	3.4	
44			3.9	3.7	3.2	
48				3.5	3.0	2.7
50				3.0	2.6	2.3
					2.4	2.1

### Main boom 35 m

Radius (m)	Jib length in (m)					
	14	23	29	35	44	
25.2	t	t	t	t	t	
30	7.5					
32	6.2					
34		5.2				
38		4.9	4.5			
44		4.2	3.9	3.5		
46			3.1	2.8	2.3	
48				2.6	2.1	
50				2.5		
				2.3		

### Main boom 38 m

Radius (m)	Jib length in (m)				
	14	23	29	35	
26.5	t	t	t	t	
32	6.6				
36	5.2	4.7			
38		4.1	3.7		
40		3.8	3.5		
44		3.5	3.2	2.9	
46			2.8	2.5	
48			2.6	2.3	
				2.1	

### Main boom 41 m

Radius (m)	Jib length in (m)			
	14	23	29	35
27.8	t	t	t	t
32	5.6			
34	4.7			
38		3.9		
40		3.4	3.0	
42		3.1	2.8	2.5
44		2.9	2.6	2.3
46			2.4	2.1
			2.2	

TLT 9834997 M 103673

Capacities in metric tonnes with luffing jib (No. 1008.xx), 32.3 t counterweight + 15 t carbody counterweight. Above lift chart is for reference only. For actual lift duty and complete chart with all available configurations please refer to lift chart in operator's cab or manual.

# Lift chart - luffing jib (No. 1008.xx)

## Main boom 45°

### Main boom 17 m

Radius (m)	Jib length in (m)								
	14	23	29	35	44				
t	t	t	t	t	t				
25.7	8.4								
28	7.6								
34		5.7							
36		5.2							
38			4.6						
42			4.0						
44				3.6					
48				3.1					
55					2.1				

### Main boom 23 m

Radius (m)	Jib length in (m)								
	14	23	29	35					
t	t	t	t	t					
30	6.0								
32	5.5								
38		4.1							
40		3.8							
44			3.0						
46			2.8						
48				2.4					
50				2.3					

### Main boom 29 m

Radius (m)	Jib length in (m)								
	14	23							
t	t	t							
34.2	4.1								
36	3.8								
42		2.7							
44		2.5							

### Main boom 35 m

Radius (m)	Jib length in (m)								
	14	17							
t	t	t							
38.4	2.6								
40	2.5								
42		2.2							

TLT 9834997 M 103673

Capacities in metric tonnes with luffing jib (No. 1008.xx), 32.3 t counterweight + 15 t carbody counterweight. Above lift chart is for reference only. For actual lift duty and complete chart with all available configurations please refer to lift chart in operator's cab or manual.

# Working range - luffing jib (No. 1309.xx) 78° - 15°

## Main boom 88° - 45°

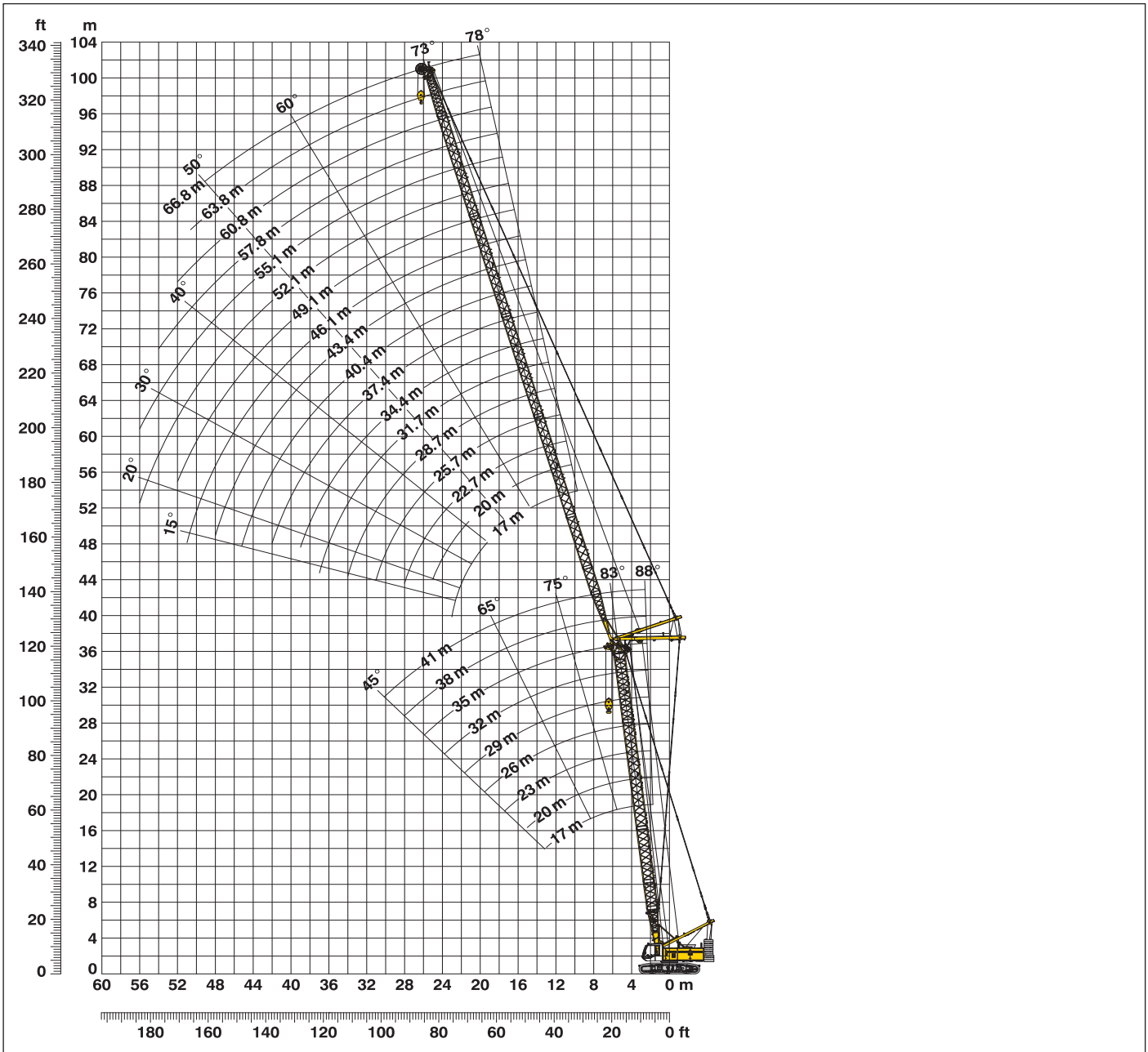

**Boom configuration for main boom lengths (17 m - 41 m)** – see table 1 on page 12

**Jib configuration for jib lengths (17 m - 66.8 m)**

	Length	Amount of luffing jib extensions																
		17	22.7	25.7	28.7	31.7	34.4	37.4	40.4	43.4	46.1	49.1	52.1	55.1	57.8	60.8	63.8	66.8
Luffing jib foot	5.5 m	1	1	1	1	1	1	1	1	1	1	1	1	1	1	1	1	1
Luffing jib insert	3 m			1		1		1		1		1		1		1		1
Luffing jib insert	6 m	1			1	1			1	1			1	1			1	1
Luffing jib insert	11.7 m		1	1	1	1	2	2	2	2	3	3	3	3	4	4	4	4
Luffing jib head	5.5 m	1	1	1	1	1	1	1	1	1	1	1	1	1	1	1	1	1
Luffing jib length (m)		17	22.7	25.7	28.7	31.7	34.4	37.4	40.4	43.4	46.1	49.1	52.1	55.1	57.8	60.8	63.8	66.8



# Lift chart - luffing jib (No. 1309.xx)

## Main boom 88°

### Main boom 17 m

Radius (m)	Jib length in (m)							
	17	22.7	28.7	34.4	46.1	52.1	57.8	66.8
6.5	t	t	t	t	t	t	t	t
8	45.7							
9	40.4	35.3						
11	36.4	32.8	27.5					
13	29.8	28.4	24.8	21.4				
14	25.3	24.2	22.0	19.3	13.8			
16	23.4	22.5	20.6	18.3	13.3	10.4		
17	20.2	19.7	18.5	16.7	12.4	10.1	8.6	
24	18.7	18.5	17.6	15.8	11.9	9.9	8.5	6.0
30		12.1	12.0	11.6	9.3	8.2	7.1	5.3
36			9.0	8.9	7.7	7.0	6.3	4.8
46				6.9	6.4	5.9	5.3	4.3
50					4.5	4.3	3.9	3.4
55						3.7	3.5	2.9
60							2.9	2.4
								2.0

### Main boom 23 m

Radius (m)	Jib length in (m)							
	17	22.7	28.7	34.4	46.1	52.1	57.8	66.8
6.7	t	t	t	t	t	t	t	t
8	38.3							
10	35.5	29.9						
11	30.8	26.8	22.8					
13	28.4	25.4	21.8	18.5				
15	24.1	22.6	19.8	17.0	11.9			
16	21.0	20.1	17.9	15.7	11.4	9.3		
18	19.7	18.9	17.2	15.0	11.1	9.1	7.8	
24	17.4	16.8	15.5	13.8	10.4	8.8	7.4	5.4
30		11.8	11.3	10.2	8.7	7.6	6.5	4.9
36			8.7	7.9	7.1	6.5	5.8	4.4
40				6.2	5.8	5.4	4.9	4.0
46					5.0	4.7	4.4	3.5
50					4.2	3.8	3.5	3.0
55						3.4	3.0	2.5
								2.5

### Main boom 29 m

Radius (m)	Jib length in (m)							
	17	22.7	28.7	34.4	46.1	52.1	57.8	66.8
7	t	t	t	t	t	t	t	t
9	30.6							
10	27.4	23.4						
11	25.8	22.3	18.8					
14	24.5	21.3	18.1	15.4				
15	20.8	18.6	15.9	13.7	10.0			
16	19.4	17.5	15.2	13.3	9.7	8.2		
18	18.2	16.7	14.6	12.8	9.5	8.0	6.8	
24	16.2	15.2	13.2	11.8	9.0	7.7	6.5	4.8
30		10.8	9.9	9.0	7.6	6.6	5.7	4.2
36			7.8	7.2	6.2	5.7	5.1	3.8
40				5.8	5.1	4.7	4.2	3.4
46					4.5	4.1	3.7	2.9
50					3.8	3.4	3.0	2.4
55						3.0	2.6	2.0
							2.2	

### Main boom 35 m

Radius (m)	Jib length in (m)							
	17	22.7	28.7	34.4	46.1	52.1	57.8	66.8
7.2	t	t	t	t	t	t	t	t
9	22.3							
10	20.3	17.4						
11	19.3	16.7	14.2					
14	18.3	15.9	13.6	11.6				
15	15.2	13.9	12.1	10.5	7.8			
16	14.2	13.3	11.5	10.1	7.6	6.4		
18	13.4	12.7	11.1	9.8	7.4	6.2	5.2	
24	12.3	11.7	10.3	9.1	6.9	5.9	4.9	3.6
30		8.6	7.9	7.3	5.8	5.0	4.2	3.0
36			6.4	5.8	4.9	4.3	3.7	2.7
40				4.9	4.0	3.6	3.0	2.3
46					3.7	3.3	2.9	2.1
48					2.9	2.5	2.1	
50					2.6	2.3		
						2.1		

### Main boom 38 m

Radius (m)	Jib length in (m)						
	17	22.7	28.7	34.4	40.4	46.1	
7.3	t	t	t	t	t	t	
9	19.3						
10	18.2	15.2					
11	17.5	14.6	12.7				
13	16.6	14.0	12.2	10.5			
14	15.0	13.0	11.4	9.9	8.5		
16	14.3	12.6	11.0	9.6	8.2	7.1	
18	12.8	11.4	10.2	9.0	7.7	6.7	
20	11.4	10.5	9.5	8.4	7.3	6.3	
24	8.2	9.5	8.7	7.9	6.8	6.0	
30		8.0	7.4	6.7	6.1	5.3	
36			6.0	5.5	5.0	4.4	
42				4.6	4.1	3.7	
46					3.4	3.0	
48						2.7	
						2.4	

### Main boom 41 m

Radius (m)	Jib length in (m)					
	22.7	25.7	28.7			
8.6	t	t	t			
10	13.5					
11	13.0	11.8	11.4			
12	12.5	11.4	11.1			
14	12.2	11.1	10.7			
15	11.4	10.5	10.0			
16	11.0	10.2	9.6			
18	10.4	10.0	9.3			
20	9.9	9.5	9.0			
22	9.5	9.0	8.7			
24	8.7	8.4	8.0			
26	8.1	7.7	7.5			
28	7.6	7.1	6.9			
30		6.7	6.4			
		5.4	6.0			
			5.7			

TLT 9834997 M 103673

Capacities in metric tonnes with luffing jib (No. 1309.xx), 32.3 t counterweight + 15 t carbody counterweight. Above lift chart is for reference only. For actual lift duty and complete chart with all available configurations please refer to lift chart in operator's cab or manual.

# Lift chart - luffing jib (No. 1309.xx)

## Main boom 83°

### Main boom 17 m

Radius (m)	Jib length in (m)							
	17	22.7	28.7	34.4	46.1	52.1	57.8	66.8
9.5	t	t	t	t	t	t	t	t
12	33.3							
13	26.4	25.2						
15	21.0	20.2	22.3					
18	16.9	16.8	19.3	18.6				
20	14.7	14.7	16.1	15.4	12.7			
22		13.0	12.9	13.8	11.9	9.5		
26		10.5	10.4	10.3	9.5	8.4	7.9	
32			7.9	7.8	7.4	7.0	6.6	5.3
36				6.6	6.3	6.0	5.7	4.9
40					5.4	5.2	4.9	4.7
48					4.0	3.8	3.6	3.2
50						3.5	3.3	2.9
55							2.7	2.4
60								2.2

### Main boom 23 m

Radius (m)	Jib length in (m)							
	17	22.7	28.7	34.4	46.1	52.1	57.8	66.8
10.2	t	t	t	t	t	t	t	t
12	28.9							
14	24.8	23.7						
16	21.3	20.4	19.5					
19	18.6	17.9	17.1	16.4				
20	15.5	15.0	14.4	13.8	11.3			
22	14.6	14.3	13.6	13.1	11.1			
24		12.9	12.3	11.9	10.5	8.4		
26		11.5	11.3	10.8	9.8	8.1	7.0	
32		10.4	10.3	9.9	9.0	7.9	6.9	4.9
38			7.8	7.7	7.0	6.6	6.2	4.6
42				6.0	5.6	5.2	4.9	4.2
48					4.8	4.5	4.2	3.7
55						3.9	3.7	3.4
60							2.8	2.6
								2.2

### Main boom 29 m

Radius (m)	Jib length in (m)							
	17	22.7	28.7	34.4	46.1	52.1	57.8	66.8
11	t	t	t	t	t	t	t	t
13	25.3							
15	21.5	20.6						
17	18.7	18.0	17.2					
20	16.5	15.9	15.2	14.5				
22	14.1	13.5	12.9	12.3	9.8			
24	12.7	12.2	11.7	11.2	9.3	7.6		
26		11.2	10.7	10.2	8.9	7.4	6.3	
30		10.2	9.8	9.3	8.4	7.2	6.1	4.4
32			8.4	8.0	7.1	6.7	5.9	4.2
36			7.6	7.4	6.6	6.2	5.7	4.1
38				6.4	5.6	5.3	4.9	4.0
46					5.9	5.3	4.9	3.9
50						4.0	3.6	3.3
55						3.3	3.2	2.9
							2.7	2.4

### Main boom 35 m

Radius (m)	Jib length in (m)							
	17	22.7	28.7	34.4	46.1	52.1	57.8	66.8
11.7	t	t	t	t	t	t	t	t
14	20.3							
16	18.4	15.9						
17	16.5	14.6	12.6					
22	15.6	14.1	12.1	10.5				
24	12.0	11.5	10.2	9.1	6.9	5.8		
28		10.5	9.7	8.6	6.6	5.6	4.7	
30		8.1	8.4	7.9	6.1	5.2	4.4	3.2
32			7.9	7.4	5.9	5.1	4.3	3.1
34			7.3	6.9	5.7	4.9	4.1	3.0
36			6.4	6.4	5.5	4.7	4.0	2.9
38				6.0	5.3	4.5	3.9	2.8
46					5.6	4.9	4.4	3.7
50						3.7	3.4	3.0
55						3.2	2.9	2.6
							2.4	2.1

### Main boom 38 m

Radius (m)	Jib length in (m)					
	17	22.7	28.7	34.4	40.4	46.1
12.1	t	t	t	t	t	t
14	17.6					
16	16.3	13.9				
18	14.9	12.9	11.1			
19	13.9	12.0	10.4	9.1		
22	13.4	11.5	10.1	8.8	7.6	
26	11.6	10.4	9.1	8.1	7.0	6.1
28		9.1	8.2	7.3	6.4	5.6
32		8.3	7.8	7.0	6.1	5.4
34			7.0	6.4	5.7	5.0
38			6.5	6.1	5.4	4.8
40				5.4	4.9	4.4
44					4.5	4.2
46						4.1
50						3.8
						3.7
						3.5
						3.1

### Main boom 41 m

Radius (m)	Jib length in (m)		
	22.7	25.7	28.7
14.1	t	t	t
15	12.1		
16	11.8	10.9	
18	11.4	10.6	9.8
19	10.7	9.8	9.3
20	10.2	9.5	8.9
22	9.9	9.2	8.6
24	9.4	8.6	8.1
26	9.0	8.2	7.6
28	8.5	7.9	7.4
30	7.7	7.7	7.1
32		7.2	6.9
34		5.7	6.6
			6.2

TLT 9834997 M 103673

Capacities in metric tonnes with luffing jib (No. 1309.xx), 32.3 t counterweight + 15 t carbody counterweight. Above lift chart is for reference only. For actual lift duty and complete chart with all available configurations please refer to lift chart in operator's cab or manual.

# Lift chart - luffing jib (No. 1309.xx)

## Main boom 75°

### Main boom 17 m

Radius (m)	Jib length in (m)							
	17	22.7	28.7	34.4	46.1	52.1	57.8	66.8
14	t	t	t	t	t	t	t	t
17	21.2							
19	17.2	16.7						
22	15.0	14.8	14.2					
28	12.4	12.3	12.1	11.7				
30		9.0	8.9	8.7	8.1			
32			8.1	7.9	7.4	7.0		
34			7.4	7.3	6.8	6.4	6.1	
36			6.8	6.7	6.3	5.9	5.6	
38				6.2	5.8	5.5	5.1	4.5
40				5.7	5.3	5.1	4.7	4.2
44				5.3	4.9	4.7	4.4	3.8
46					4.2	4.0	3.8	3.2
50					3.9	3.7	3.5	3.0
55					3.3	3.2	3.0	2.5
						2.6	2.4	

### Main boom 23 m

Radius (m)	Jib length in (m)							
	17	22.7	28.7	34.4	46.1	52.1	57.8	66.8
15.6	t	t	t	t	t	t	t	t
18	17.6							
22	15.2	14.5						
24	12.0	11.8	11.2					
28	10.7	10.6	10.2	9.7				
30		8.7	8.5	8.2	7.3			
32		7.9	7.8	7.5	6.7			
34			7.1	6.9	6.2	5.8		
36			6.5	6.4	5.7	5.3	5.0	
38			6.0	5.9	5.3	4.9	4.6	
40				5.4	4.9	4.5	4.2	3.6
44				5.0	4.6	4.2	3.9	3.3
46					3.9	3.6	3.3	2.8
50					3.6	3.3	3.0	2.5
55					3.1	2.9	2.6	2.1
						2.4	2.1	

### Main boom 29 m

Radius (m)	Jib length in (m)							
	17	22.7	28.7	34.4	46.1	52.1	57.8	66.8
17.2	t	t	t	t	t	t	t	t
20	14.6							
24	12.5	11.9						
26	10.3	9.8	9.3					
30	9.2	9.0	8.5	8.1				
32		7.5	7.2	6.8	6.0			
36			6.7	6.3	5.5	5.1		
38			5.7	5.4	4.7	4.3	4.0	
40				5.1	4.4	4.0	3.6	
42				4.7	4.0	3.7	3.3	2.7
44				4.3	3.7	3.4	3.1	2.5
46					3.5	3.1	2.8	2.2
48					3.2	2.9	2.6	2.0
50					3.0	2.7	2.3	
					2.8	2.4	2.1	

### Main boom 35 m

Radius (m)	Jib length in (m)							
	17	22.7	28.7	34.4	46.1	52.1	57.8	66.8
18.7	t	t	t	t	t	t	t	t
22	12.2							
24	10.3	9.8						
26	9.4	8.9	8.4					
28	8.6	8.2	7.7					
32		7.5	7.1	6.7				
34		6.4	6.0	5.7	4.9			
36			5.6	5.2	4.5	4.1		
38			5.2	4.9	4.1	3.7	3.3	
40			4.9	4.5	3.8	3.4	3.1	
42				4.2	3.5	3.1	2.8	2.1
44				3.9	3.2	2.9	2.5	
46				3.7	3.0	2.6	2.3	
50					2.8	2.4	2.1	
					2.4	2.0		

### Main boom 38 m

Radius (m)	Jib length in (m)						
	17	22.7	28.7	34.4	40.4	46.1	
19.5	t	t	t	t	t	t	
22	11.1						
26	9.8	9.3					
28	8.2	7.8	7.3				
30	7.5	7.1	6.7	6.3			
32		6.6	6.1	5.8	5.3		
34		6.1	5.7	5.3	4.9	4.5	
38		5.7	5.3	4.9	4.5	4.1	
40			4.6	4.2	3.8	3.5	
42			4.2	3.9	3.6	3.2	
44				3.7	3.3	3.0	
46				3.4	3.0	2.7	
48					2.8	2.5	
50					2.6	2.3	
					2.4	2.1	

### Main boom 41 m

Radius (m)	Jib length in (m)			
	22.7	25.7	28.7	
22.7	t	t	t	
24	8.5			
26	8.0	7.7		
28	7.3	7.0	6.8	
30	6.7	6.5	6.2	
32	6.2	6.0	5.8	
34	5.7	5.5	5.3	
36	5.3	5.1	4.9	
38		4.7	4.6	
40			4.2	
			4.0	

TLT 9834997 M 103673

Capacities in metric tonnes with luffing jib (No. 1309.xx), 32.3 t counterweight + 15 t carbody counterweight. Above lift chart is for reference only. For actual lift duty and complete chart with all available configurations please refer to lift chart in operator's cab or manual.

# Lift chart - luffing jib (No. 1309.xx)

## Main boom 65°

### Main boom 17 m

Radius (m)	Jib length in (m)							
	17	22.7	28.7	34.4	46.1	52.1	57.8	66.8
19.3	t	t	t	t	t	t	t	t
24	13.6							
26	10.4	10.3						
28	9.3	9.2						
30		8.4	8.2					
36		7.6	7.5	7.3				
38			5.8	5.6	5.1			
40				5.2	4.7			
42				4.8	4.4	4.1		
44				4.4	4.0	3.8		
46					3.7	3.5	3.2	
48					3.4	3.2	2.9	
50					3.2	3.0	2.7	2.2
55					2.9	2.7	2.5	
					2.2	2.0		

### Main boom 23 m

Radius (m)	Jib length in (m)							
	17	22.7	28.7	34.4	46.1	52.1	57.8	
21.9	t	t	t	t	t	t	t	
26	10.9							
28	8.7	8.6						
30	7.9	7.8						
32		7.1	6.8					
34		6.5	6.3	6.0				
38		5.9	5.7	5.5				
40			4.9	4.7				
42				4.3	3.8			
44				4.0	3.5	3.1		
46				3.7	3.2	2.9		
48					3.0	2.6	2.3	
50					2.8	2.4	2.1	
55					2.5	2.2		
					2.0			

### Main boom 29 m

Radius (m)	Jib length in (m)					
	17	22.7	28.7	34.4	46.1	
24.4	t	t	t	t	t	
28	8.6					
30	7.2	6.9				
32	6.6	6.4				
36		5.9	5.5			
42		4.9	4.7	4.3		
44			3.7	3.5	2.7	
46				3.2	2.5	
48				3.0	2.3	
				2.7	2.1	

### Main boom 35 m

Radius (m)	Jib length in (m)				
	17	22.7	28.7	34.4	
27	t	t	t	t	
32	6.6				
34	5.4	5.0			
38		4.6	4.2		
40		4.0	3.6	3.2	
42			3.3	3.0	
44			3.1	2.8	
46			2.9	2.5	
48				2.3	
				2.2	

### Main boom 38 m

Radius (m)	Jib length in (m)				
	17	22.7	28.7	34.4	37.4
28.2	t	t	t	t	t
32	5.7				
34	4.9	4.5			
36	4.5	4.2			
40		3.9	3.4		
42		3.3	2.9	2.6	2.3
44			2.7	2.4	2.2
46			2.5	2.2	
			2.3		

### Main boom 41 m

Radius (m)	Jib length in (m)			
	22.7	25.7	28.7	
32.8	t	t	t	
34	3.9			
36	3.7			
38	3.4	3.2		
40	3.1	2.9	2.7	
42	2.9	2.7	2.5	
44		2.5	2.3	
		2.3	2.1	

TLT 9834997 M 103673

Capacities in metric tonnes with luffing jib (No. 1309.xx), 32.3 t counterweight + 15 t carbody counterweight. Above lift chart is for reference only. For actual lift duty and complete chart with all available configurations please refer to lift chart in operator's cab or manual.

# Lift chart - luffing jib (No. 1309.xx)

## Main boom 45°

### Main boom 17 m

Radius (m)	Jib length in (m)							
	17	22.7	28.7	34.4				
t	t	t	t					
28.2	7.3							
30	6.7							
34		5.5						
36		5.0						
38			4.4					
40			4.1					
42			3.8					
44				3.3				
46				3.1				

### Main boom 23 m

Radius (m)	Jib length in (m)							
	17	22.7	28.7	34.4				
t	t	t	t					
32.4	5.1							
34	4.8							
38		3.9						
40		3.6						
42			3.0					
44			2.8					
46			2.6					
48				2.2				

TLT 9834997 M 103673

### Main boom 29 m

Radius (m)	Jib length in (m)						
	17	22.7					
t	t	t					
36.7	3.4						
38	3.2						
42		2.5					
44		2.3					

Capacities in metric tonnes with luffing jib (No. 1309.xx), 32.3 t counterweight + 15 t carbody counterweight. Above lift chart is for reference only. For actual lift duty and complete chart with all available configurations please refer to lift chart in operator's cab or manual.

# Working range - fixed jib (No. 0806.xx) 15° and 30°

Main boom 88° - 30°

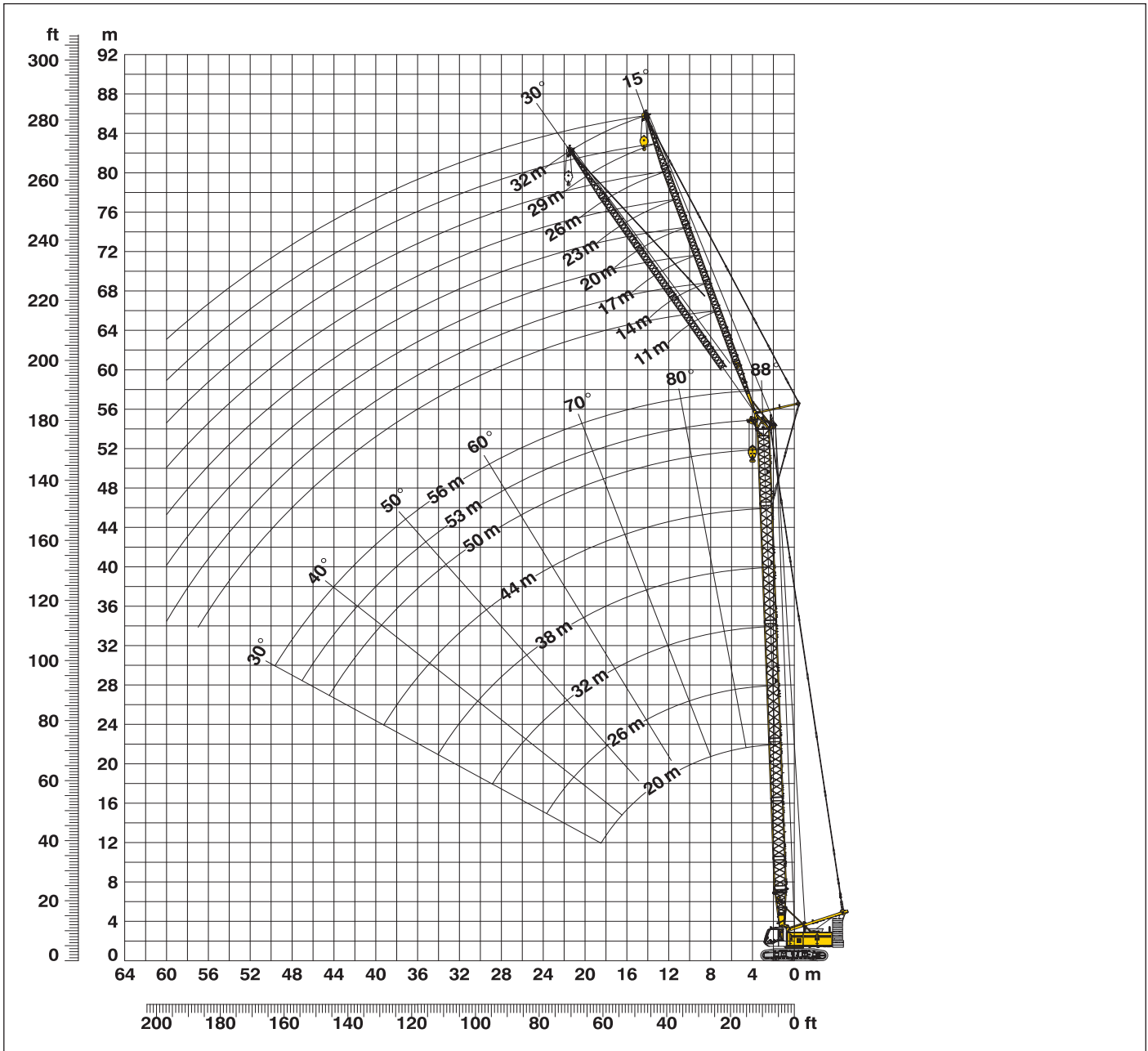

## Boom configuration for boom lengths (20 m - 56 m) – see table 1 on page 12

### Fixed jib configuration for fixed jib lengths (11 m - 32 m)

	Length	Amount of fixed jib extensions								
		1	1	1	1	1	2	2	3	3
Fixed jib foot	5.5 m	1	1	1	1	1	1	1	1	1
Fixed jib insert	3 m		1			1		1		1
Fixed jib insert	6 m			1		1	2	2	3	3
Fixed jib head	5.5 m	1	1	1	1	1	1	1	1	1
Fixed jib length (m)		11	14	17	20	23	26	29	32	

# Lift chart - fixed jib (No. 0806.xx)

Offset 15°

## Main boom 20 m

Radius (m)	Fixed jib length in (m)			
	11	20	26	32
5	t	t	t	t
9	24.0	12.6		
11	21.7	11.9	7.7	
14	19.9	10.9	7.1	4.7
18	16.0	9.7	6.4	4.3
20	13.9	9.2	6.1	4.1
24	10.9	8.4	5.5	3.8
26	9.7	8.0	5.3	3.6
28	8.7	7.8	5.1	3.5
30	7.9	7.5	4.9	3.4
34		6.9	4.6	3.2
38		5.8	4.3	3.0
44			4.2	2.8
50				2.8

## Main boom 26 m

Radius (m)	Fixed jib length in (m)			
	11	20	26	32
5.2	t	t	t	t
9	24.0	12.2		
12	20.6	11.2	7.3	
14	19.3	10.6	7.0	4.6
18	15.8	9.6	6.3	4.2
20	13.6	9.2	6.0	4.0
24	10.6	8.4	5.5	3.7
26	9.4	8.1	5.3	3.6
28	8.5	7.8	5.1	3.5
30	7.6	7.5	5.0	3.4
34	6.2	6.7	4.6	3.2
44		4.3	4.1	2.8
50			3.5	2.7
55				2.7

## Main boom 32 m

Radius (m)	Fixed jib length in (m)			
	11	20	26	32
5.4	t	t	t	t
9	22.8	11.3		
12	20.8	10.6	7.0	
14	18.1	10.1	6.7	4.5
18	15.4	9.2	6.2	4.1
20	13.4	8.9	5.9	4.0
24	10.4	8.2	5.5	3.7
28	8.3	7.6	5.1	3.5
32	6.7	6.9	4.8	3.3
36	5.5	5.9	4.5	3.1
40	4.5	4.9	4.3	3.0
48		3.4	3.6	2.7
55			2.7	2.7
60				2.3

## Main boom 38 m

Radius (m)	Fixed jib length in (m)			
	11	20	26	32
5.6	t	t	t	t
10	20.5	10.4		
12	17.4	10.1	6.7	
14	16.3	9.6	6.5	4.3
18	14.6	8.9	6.0	4.1
20	12.9	8.5	5.8	3.9
24	10.1	7.9	5.4	3.7
28	8.0	7.4	5.0	3.4
32	6.4	6.8	4.7	3.2
40	4.2	4.7	4.2	2.9
44	3.5	3.9	4.1	2.8
50		2.9	3.1	2.7
55			2.4	2.6
60				2.0

## Main boom 44 m

Radius (m)	Fixed jib length in (m)			
	11	20	26	32
5.8	t	t	t	t
10	17.4	9.5		
12	14.9	9.2	6.3	
14	14.1	8.9	6.1	4.1
18	12.7	8.2	5.7	3.9
20	12.0	7.9	5.5	3.8
26	8.8	7.0	5.0	3.4
30	6.9	6.4	4.7	3.2
34	5.6	5.9	4.4	3.1
38	4.5	4.9	4.2	2.9
42	3.6	4.0	4.0	2.8
46	2.9	3.3	3.5	2.7
50	2.3	2.7	2.9	2.6
55		2.0	2.2	2.4

## Main boom 50 m

Radius (m)	Fixed jib length in (m)			
	11	20	26	32
6	t	t	t	t
10	14.7	8.6		
12	12.7	8.4	5.8	
15	11.5	7.9	5.6	3.9
18	10.5	7.4	5.4	3.7
20	9.9	7.1	5.2	3.6
26	8.2	6.2	4.7	3.3
30	6.6	5.7	4.4	3.1
34	5.3	5.2	4.1	3.0
38	4.2	4.6	3.9	2.8
42	3.4	3.8	3.6	2.7
46	2.6	3.0	3.2	2.6
50	2.0	2.4	2.6	2.5
55				2.1

TLT 9834997 M 103673

## Main boom 53 m

Radius (m)	Fixed jib length in (m)			
	11	20	26	32
6.1	t	t	t	t
10	13.4	8.1		
12	11.7	7.9	5.6	
15	10.8	7.5	5.4	3.8
18	9.9	7.0	5.2	3.7
20	9.4	6.7	5.0	3.5
24	8.5	6.2	4.7	3.3
30	6.4	5.4	4.3	3.1
34	5.1	5.0	4.0	2.9
38	4.1	4.4	3.8	2.8
42	3.2	3.6	3.5	2.7
46	2.5	2.9	3.0	2.6
48	2.2	2.6	2.8	2.5
50		2.3	2.5	2.5

## Main boom 56 m

Radius (m)	Fixed jib length in (m)			
	11	17	20	23
6.2	t	t	t	t
9	11.6	8.5		
10	10.9	8.4	7.3	
11	10.6	8.3	7.3	6.3
14	9.7	7.8	6.9	6.1
18	8.6	7.0	6.4	5.7
22	7.7	6.3	5.8	5.2
26	6.8	5.7	5.2	4.8
30	6.1	5.2	4.8	4.4
34	4.9	4.7	4.3	4.0
38	4.0	4.2	3.9	3.6
42	3.1	3.4	3.4	3.3
48	2.1	2.4	2.5	2.6
50		2.1	2.2	2.3

Capacities in metric tonnes with fixed jib (No. 0806.xx), 32.3 t counterweight + 15 t carbody counterweight. Above lift chart is for reference only. For actual lift duty and complete chart with all available configurations please refer to lift chart in operator's cab or manual.



# Lift chart - fixed jib (No. 0806.xx)

Offset 30°

## Main boom 20 m

Radius (m)	Fixed jib length in (m)			
	11	20	26	32
7.6	t	t	t	t
14	18.5	9.8		
17	16.8	9.1	6.0	
22	12.4	8.0	5.4	3.6
24	11.0	7.7	5.2	3.6
26	9.8	7.6	5.0	3.4
28	8.8	7.4	4.9	3.3
30	7.9	7.3	4.7	3.2
34		6.9	4.5	3.1
36		6.5	4.4	3.0
38		5.9	4.3	3.0
42			4.3	2.9
44			4.3	2.8
50				2.9

## Main boom 26 m

Radius (m)	Fixed jib length in (m)			
	11	20	26	32
7.8	20.6			
14	18.2	9.6		
17	16.8	9.0	5.8	
22	12.2	8.2	5.4	3.6
24	10.8	8.0	5.2	3.5
26	9.6	7.8	5.0	3.4
28	8.6	7.6	4.9	3.3
30	7.8	7.3	4.7	3.2
34	6.3	6.9	4.5	3.1
42		4.8	4.2	2.9
44		4.4	4.2	2.8
46			4.2	2.8
50			3.6	2.8
55				2.9

## Main boom 32 m

Radius (m)	Fixed jib length in (m)			
	11	20	26	32
8	19.1			
14	16.3	9.1		
18	14.4	8.4	5.6	
22	12.1	7.7	5.3	3.5
24	10.7	7.4	5.1	3.5
26	9.5	7.2	4.9	3.4
28	8.5	7.0	4.8	3.3
30	7.6	6.7	4.7	3.2
34	6.2	6.3	4.5	3.1
40	4.6	5.1	4.2	2.9
46		3.9	4.1	2.7
50		3.2	3.5	2.7
55			2.7	2.7
60				2.3

## Main boom 38 m

Radius (m)	Fixed jib length in (m)			
	11	20	26	32
5.6	20.5			
10	18.5	10.4		
12	17.4	10.1	6.7	
14	16.3	9.6	6.5	4.3
18	14.6	8.9	6.0	4.1
22	11.5	8.2	5.5	3.8
26	9.0	7.6	5.2	3.5
30	7.2	7.1	4.8	3.3
34	5.8	6.2	4.6	3.1
42	3.8	4.2	4.1	2.9
44	3.5	3.9	4.1	2.8
50		2.9	3.1	2.7
55			2.4	2.6
60				2.0

## Main boom 44 m

Radius (m)	Fixed jib length in (m)			
	11	20	26	32
8.4	14.6			
14	12.8	7.8		
18	11.4	7.4	5.1	
22	10.3	6.9	4.9	3.4
24	9.8	6.6	4.8	3.3
26	9.1	6.4	4.7	3.2
28	8.1	6.2	4.6	3.1
30	7.2	6.0	4.5	3.1
32	6.4	5.8	4.4	3.0
34	5.8	5.6	4.3	3.0
42	3.8	4.3	3.9	2.8
50	2.4	2.8	3.1	2.6
55		2.1	2.4	2.6
60				2.0

## Main boom 50 m

Radius (m)	Fixed jib length in (m)			
	11	20	26	32
8.7	12.1			
15	10.5	7.0		
18	9.7	6.7	4.8	
22	8.8	6.1	4.7	3.2
24	8.3	5.9	4.5	3.2
26	7.9	5.6	4.4	3.1
28	7.4	5.4	4.3	3.0
30	6.9	5.2	4.2	3.0
32	6.2	5.0	4.0	2.9
34	5.5	4.8	3.9	2.9
36	4.9	4.6	3.8	2.8
42	3.5	4.0	3.4	2.7
50	2.1	2.6	2.9	2.5
55			2.2	2.3

TLT 9834997 M 103673

## Main boom 53 m

Radius (m)	Fixed jib length in (m)			
	11	20	26	32
8.8	11.1			
15	9.9	6.6		
18	9.2	6.3	4.7	
22	8.3	5.8	4.5	3.1
24	8.0	5.6	4.4	3.1
26	7.6	5.4	4.3	3.0
30	6.7	5.0	4.0	2.9
32	6.0	4.8	3.9	2.9
34	5.4	4.6	3.8	2.8
36	4.8	4.5	3.7	2.8
38	4.3	4.3	3.5	2.7
42	3.4	3.9	3.3	2.6
50	2.0	2.5	2.8	2.4
55			2.1	2.3

## Main boom 56 m

Radius (m)	Fixed jib length in (m)			
	11	14	20	23
8.9	9.8			
11	9.6	8.3		
15	8.7	7.8	6.0	
17	8.3	7.4	5.8	5.1
18	8.1	7.3	5.8	5.0
19	7.8	7.1	5.6	5.0
20	7.6	6.9	5.5	4.9
26	6.6	6.0	4.9	4.4
30	5.9	5.4	4.5	4.1
34	5.2	4.9	4.1	3.8
38	4.2	4.3	3.8	3.5
42	3.3	3.5	3.4	3.2
48	2.2	2.4	2.7	2.8
50		2.1	2.4	2.6

Capacities in metric tonnes with fixed jib (No. 0806.xx), 32.3 t counterweight + 15 t carbody counterweight. Above lift chart is for reference only. For actual lift duty and complete chart with all available configurations please refer to lift chart in operator's cab or manual.

# Notice



