

Concept and characteristics

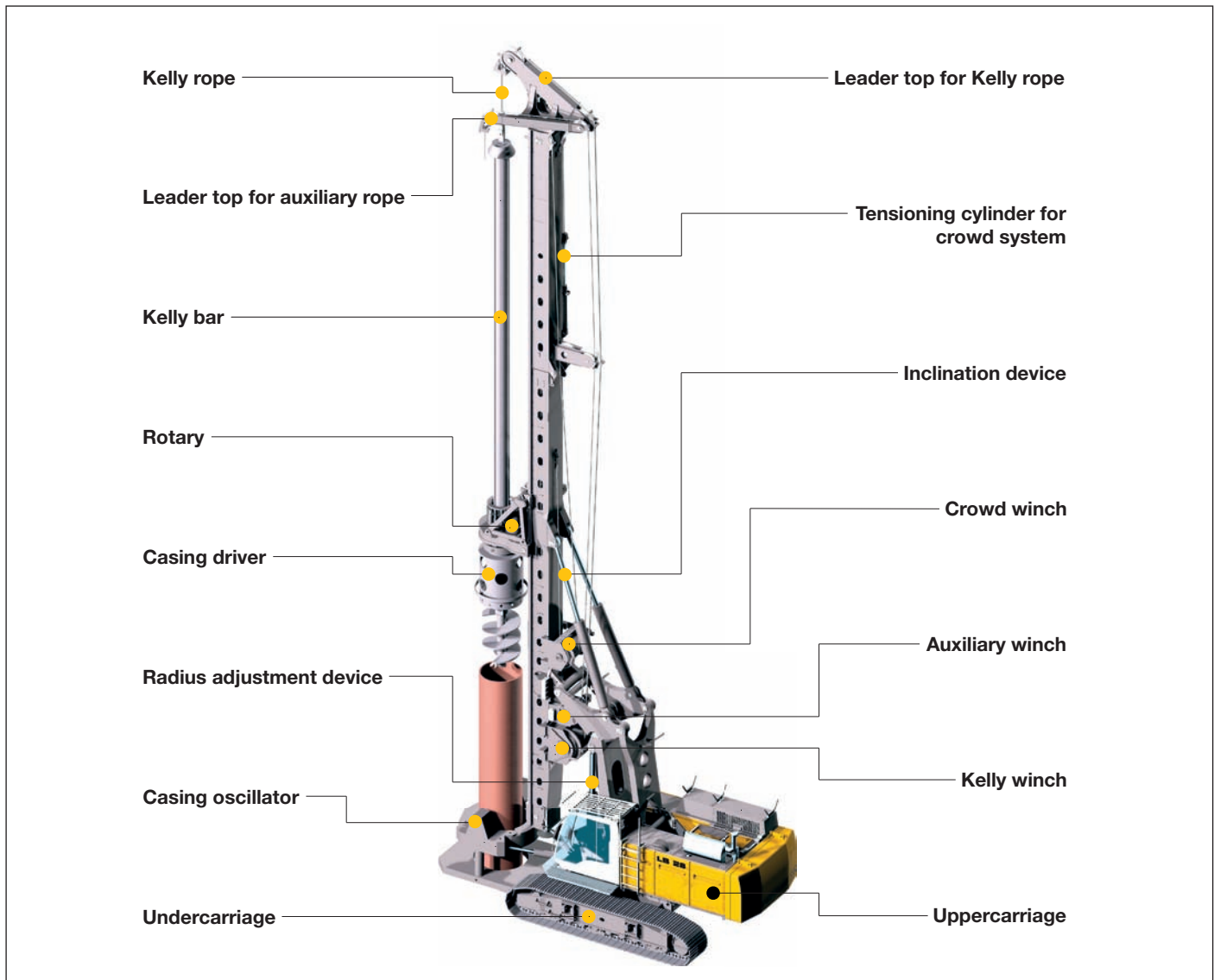

- High engine output with automatic engine speed control
- Controlled entirely from cab
- Sturdy and solid rig design
- Solid parallel kinematics on the basic machine
- High pull and push forces
- High torque
- Completely self-rigging (no auxiliary machines required)
- Large range of working tools (all common drilling works can be performed)

- Stepless leader inclination 5° forward - 15° backward depending on type of equipment
- Automatic vertical alignment
- High alignment forces
- Simultaneous control of several movements via Load-sensing multi-circuit hydraulics
- Quick change of rotaries possible through quick connection
- Equipment design according to latest European regulations and standards
- All components designed to fulfill the requirements of a drilling rig
- High manufacturing quality through quality control by the PDE®-system

Dimensions

Basic machine LB 28

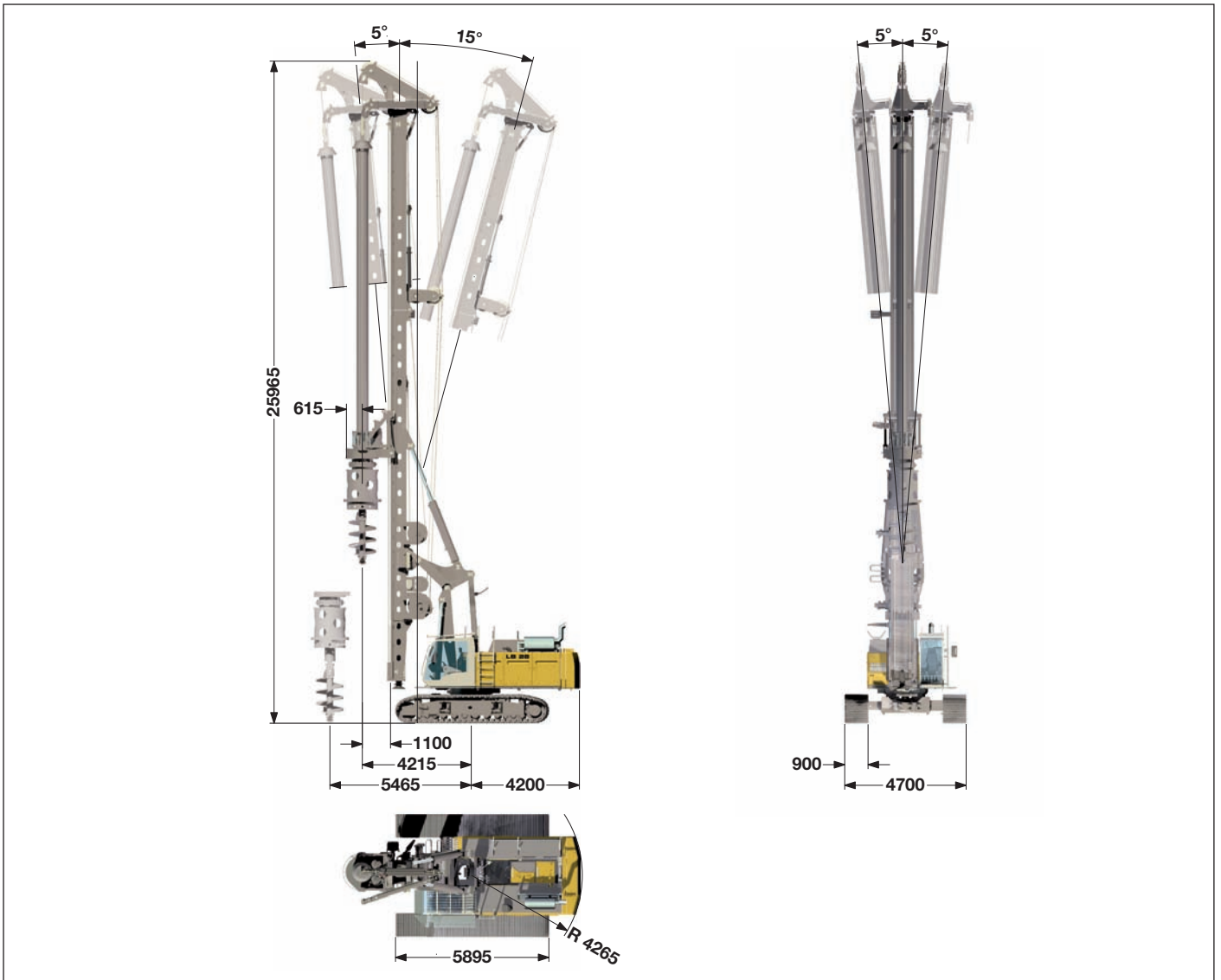

Technical data

| | |
|-------------------------------------|---------|
| Total height | 25.96 m |
| Max. pull, leader on ground | 400 kN |
| Max. torque | 286 kNm |
| Stepless rig inclination adjustment | |
| Lateral inclination | ± 5° |
| Forward inclination | 5° |
| Backward inclination | 15° |

Operating weight

| | |
|--|--------|
| Total weight with 800 mm 3-web shoes | 95.0 t |
| Total weight with 900 mm 3-web shoes | 95.6 t |
| The operating weight includes the basic machine LB 28 (with rotary and Kelly bar MD 28/3/30) and 15.3 t counterweight. | |

Transport dimensions and weights

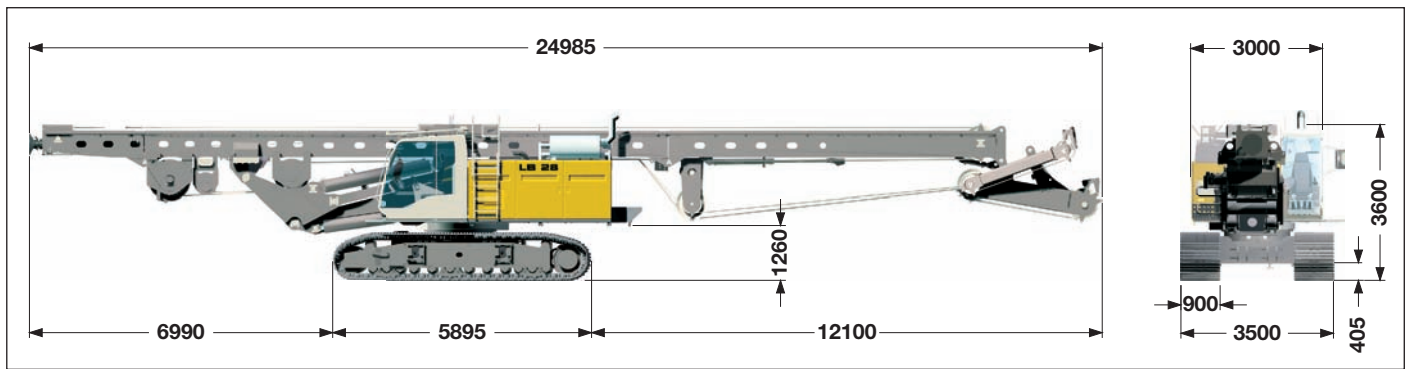

Transport with leader

includes the basic machine (ready for operation) with leader, without working tools (such as rotary, Kelly bar etc.) and without counterweight.

Dimensions and weights

| | |
|---------------------------------------|--------|
| Leader length | 22 m |
| Weight complete without counterweight | 68.2 t |

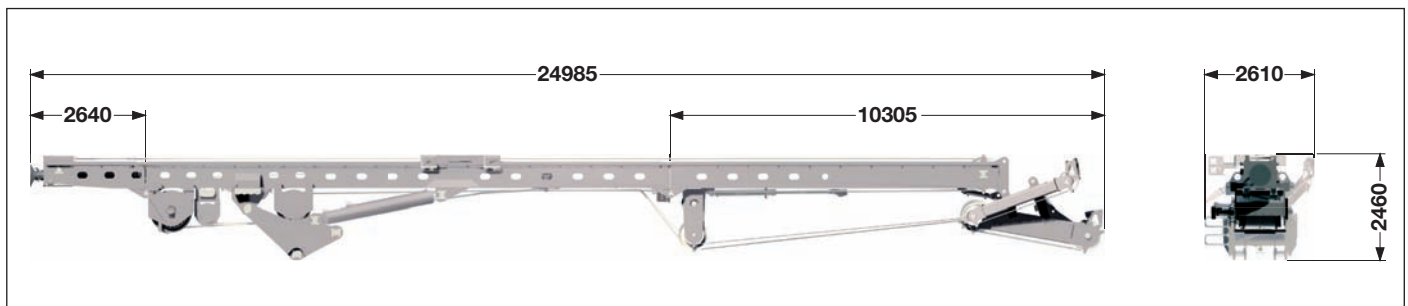

Transport leader

includes the leader without working tools (such as rotary, Kelly bar etc.).

Dimensions and weights

| | |
|--|--------|
| Leader length | 22 m |
| Weight complete | 24.2 t |
| Lower part of the leader | 1.5 t |
| Upper part of the leader with leader top | 4.6 t |

Transport dimensions and weights

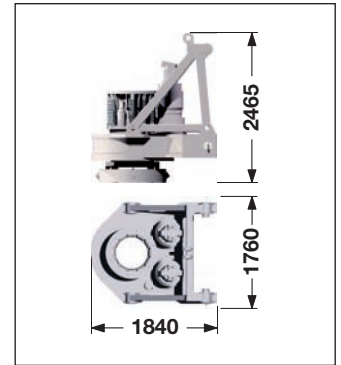
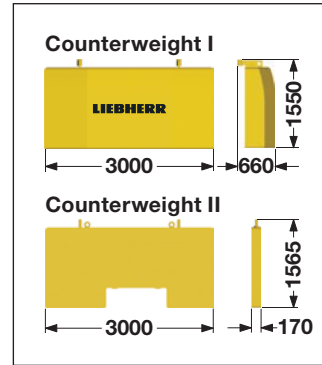
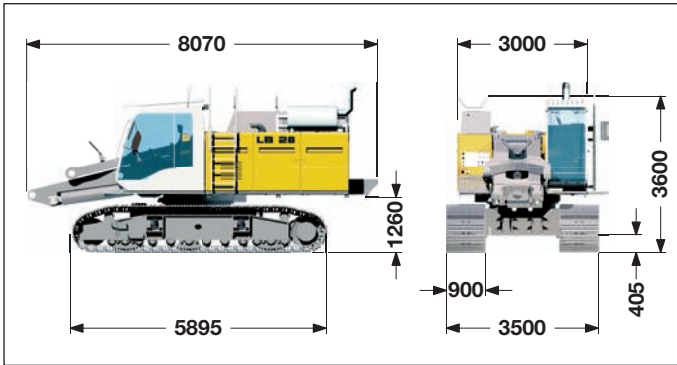

Transport basic machine

ready for operation, without counterweight.

Transport weight ————— 44.0 t

Weights

Counterweight I ——— 10.2 t

Counterweight II ——— 5.2 t

Rotary

Transport weight

BA 280 ————— 6.7 t

Weights can vary with the final configuration of the machine.

The figures in this brochure may include options which are not within the standard scope of supply of the machine.

Rotary BA 280 with shock absorber

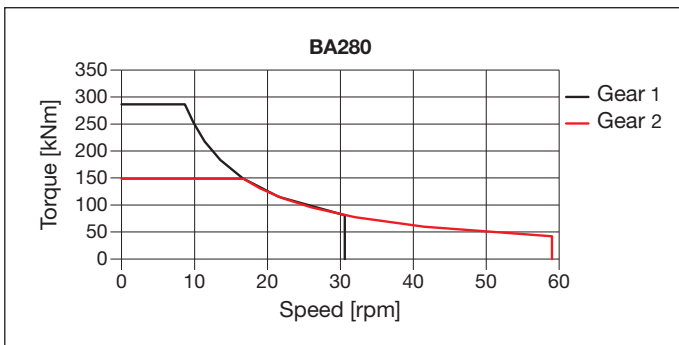
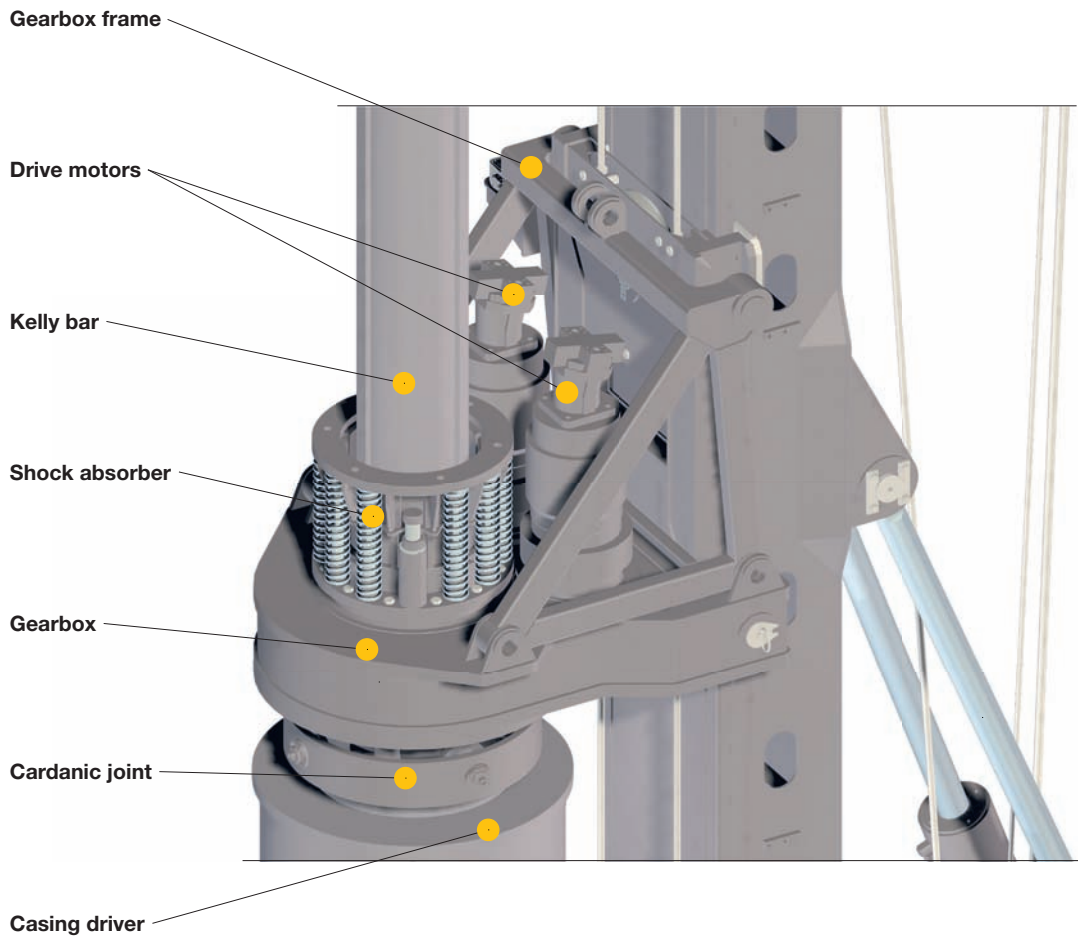

- 2-stage-gear drive for flexible adaptation to soil conditions
- Due to stepless speed control via joystick optimum and precise alignment and rock drilling is possible even at low speed levels; it is not required to preselect an operating mode
- Kelly shock absorber and rubber bearing relieve the material and reduce noise emission
- Thanks to the Kelly shock absorber the Kelly bar is guided at greater length
- Various drive adapters provide compatibility with other systems

Kelly drilling

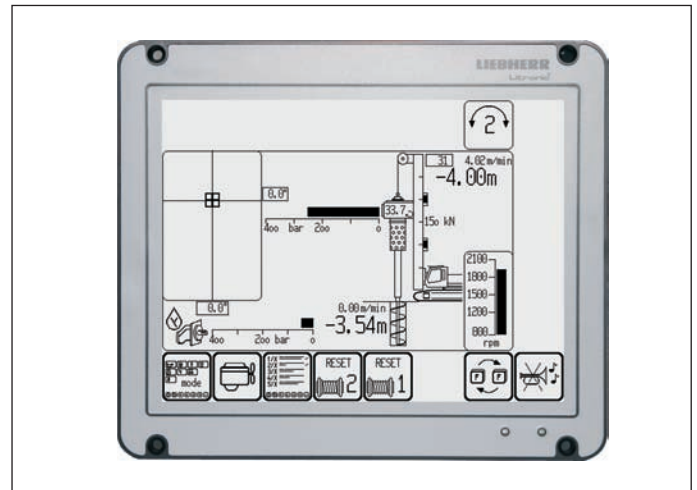
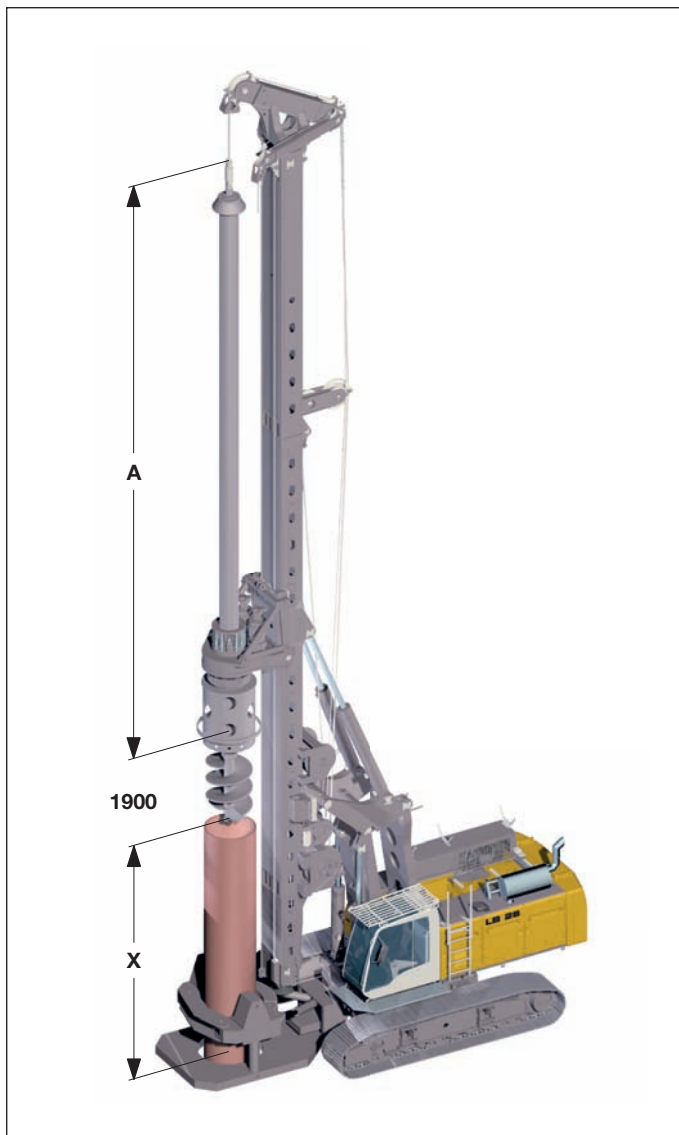

Display for Kelly drilling

Technical data

| | | |
|-------------------------|----------------------|---------|
| Drilling drive - torque | 1 st gear | 286 kNm |
| Drilling drive - speed | 1 st gear | 30 rpm |
| Drilling drive - torque | 2 nd gear | 148 kNm |
| Drilling drive - speed | 2 nd gear | 59 rpm |

Performance data

| | |
|-------------------------|-----------------|
| Max. drilling diameter* | 1900 mm uncased |
| Max. drilling diameter* | 1500 mm cased |

*) Other drilling diameters available on request.
 Other Kelly bars available on request.
 When using a casing oscillator, value X has to be reduced by 1500 mm.

Kelly bars

| | A | X | Drilling depth | Weight | Kelly Ø |
|------------|-------|-------|----------------|--------|---------|
| | (mm) | (mm) | (m) | (t) | (mm) |
| MD 28/3/24 | 9880 | 11200 | 22 | 5.0 | 419 |
| MD 28/3/27 | 10880 | 10200 | 25 | 5.5 | 419 |
| MD 28/3/30 | 11880 | 9200 | 28 | 5.9 | 419 |
| MD 28/3/33 | 12880 | 8200 | 31 | 6.4 | 419 |
| MD 28/3/36 | 13880 | 7200 | 34 | 6.8 | 419 |
| MD 28/4/36 | 11450 | 9700 | 34 | 7.3 | 419 |
| MD 28/4/42 | 12950 | 8200 | 40 | 8.1 | 419 |
| MD 28/4/48 | 14450 | 6700 | 46 | 9.0 | 419 |
| MD 28/4/54 | 15950 | 5200 | 52 | 9.8 | 419 |
| MD 28/4/60 | 17450 | 3700 | 58 | 10.7 | 419 |
| MD 28/4/66 | 18950 | 2200 | 64 | 11.6 | 419 |
| MD 28/4/72 | 20450 | 700 | 70 | 12.4 | 419 |

Continuous flight auger drilling

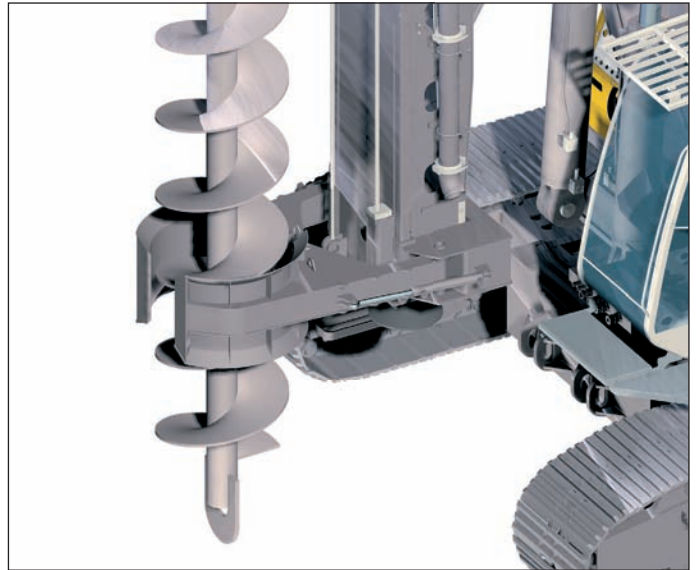
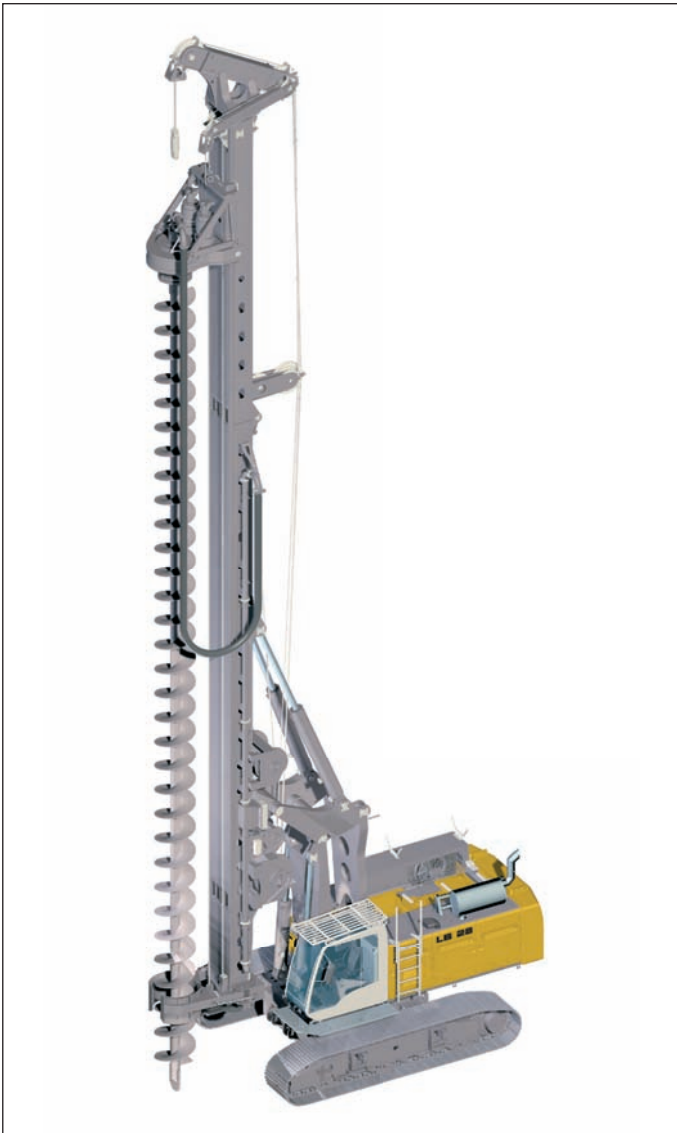

Auger with auger guide

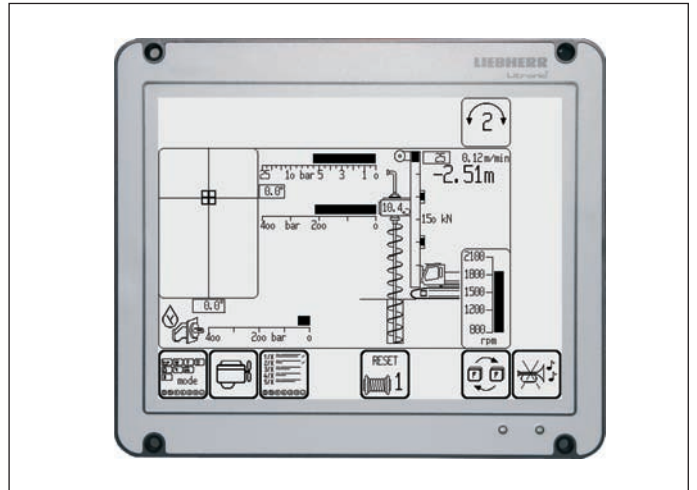

Display for continuous flight auger drilling

Technical data

| | | |
|-------------------------|----------------------|---------|
| Drilling drive - torque | 1 st gear | 286 kNm |
| Drilling drive - speed | 1 st gear | 30 rpm |
| Drilling drive - torque | 2 nd gear | 148 kNm |
| Drilling drive - speed | 2 nd gear | 59 rpm |

Performance data

| | |
|---|---------|
| Drilling depth with auger cleaner* | 17.3 m |
| Drilling depth without auger cleaner* | 17.8 m |
| Drilling depth with 8 m Kelly extension, without auger cleaner | 25.8 m |
| Max. pull force (crowd winch and Kelly winch) | 900 kN |
| Max. push force (weight of rotary and auger to be added) | 200 kN |
| Max. drilling diameter** | 1000 mm |

*) Without Kelly extension

**) Other drilling diameters available on request.

Double rotary drilling

Model DBA 200

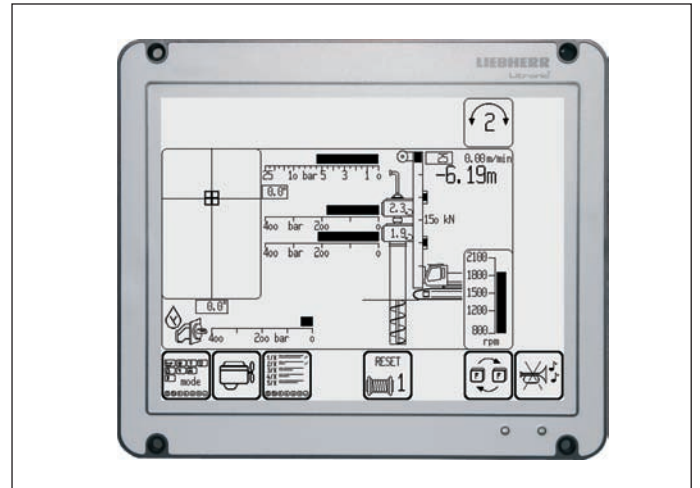

Display for double rotary drilling

Technical data

| | | |
|----------------------------|----------------------|---------|
| Drilling drive I - torque | 1 st gear | 195 kNm |
| Drilling drive I - speed | 1 st gear | 9 rpm |
| Drilling drive I - torque | 2 nd gear | 97 kNm |
| Drilling drive I - speed | 2 nd gear | 18 rpm |
| Drilling drive II - torque | 1 st gear | 103 kNm |
| Drilling drive II - speed | 1 st gear | 17 rpm |
| Drilling drive II - torque | 2 nd gear | 51 kNm |
| Drilling drive II - speed | 2 nd gear | 34 rpm |
| Max. drilling diameter* | | 620 mm |
| Max. drilling depth | | 17.8 m |
| Max. pull force | | 900 kN |

*) Other drilling diameters available on request.

Twin mix equipment

Model DMA 35

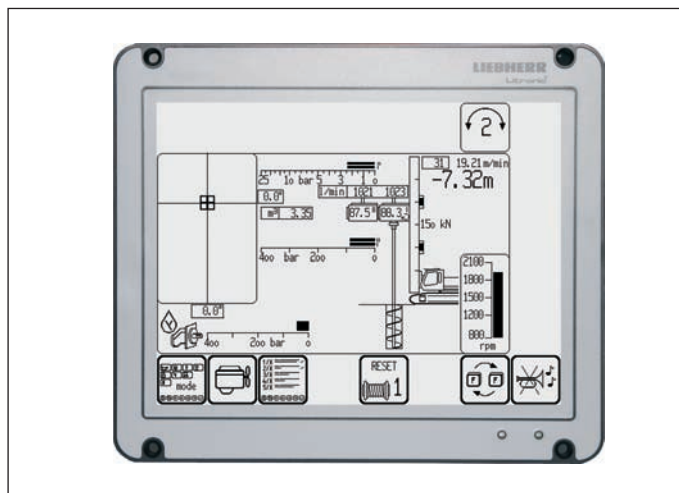

Display for soil mixing

Technical data

| | | |
|-------------------------|----------------------|----------|
| Drilling drive - torque | 1 st gear | 35 kNm |
| Drilling drive - speed | 1 st gear | 55 rpm |
| Drilling drive - torque | 2 nd gear | 17.5 kNm |
| Drilling drive - speed | 2 nd gear | 111 rpm |
| Max. drilling depth | | 17.8 m |
| Max. diameter* | | 700 mm |

*) Other diameters available on request

Technical description



Engine

Power rating according to ISO 9249, 350 kW (469 hp) at 1900 rpm
Engine type _____ Liebherr D 846 A7
Fuel tank _____ 700 l capacity with continuous level indicator and reserve warning
Engine complies with NRMM exhaust certification EPA/CARB Tier 3 and 97/68 EC Stage III.



Hydraulic system

The main pumps are operated by a distributor gearbox. Axial piston displacement pumps work in open circuits supplying oil only when needed (flow control on demand).

The hydraulic pressure peaks are absorbed by the integrated automatic pressure compensation, which relieves the pump and saves fuel.

Pumps for working tools _____ 2x 350 l/min
Separate pump for kinematics _____ 180 l/min
Hydraulic oil tank _____ 800 l
Max. working pressure _____ 350 bar

The cleaning of the hydraulic oils occurs via an electronically monitored pressure and return filter.
Any clogging is shown on the display in the cab.
The use of synthetic environmentally friendly oil is also possible.



Crawlers

Propulsion through axial piston motor, hydraulically released spring loaded multi-disc brake, maintenance free crawler tracks, hydraulic chain tensioning device.

Drive speed _____ 0 – 1.9 km/h
Track force _____ 622 kN
Width of 3-web track shoes _____ 900 mm



Swing

Consists of triple-row roller bearing with external teeth and two swing drives, fixed axial piston hydraulic motor, spring loaded and hydraulically released multi-disc holding brake, planetary gearbox and pinion. Selector for 3 speed ranges to increase swing precision. Swing speed from 0 – 2 rpm is continuously variable.



Control

The control system – developed and manufactured by Liebherr – is designed to withstand extreme temperatures and the many heavy-duty construction tasks for which this machine has been designed. Complete machine operating data are displayed on a high resolution monitor screen. A GSM modem allows for remote inquiry of machine data and error indications. To ensure clarity of the information on display, different levels of data are shown in enlarged lettering and symbols.

Control and monitoring of the sensors are also handled by this high technology system. Error indications are automatically displayed on the monitor in clear text. The machine is equipped with proportional control for all movements, which can be carried out simultaneously. Two joysticks are required for operation. Pedal control can be changed to hand control.

Options:

- PDE®: Process data recording
- GSM modem



Kelly winch with freewheeling

Line pull effective (1st layer) _____ 250 kN
Rope diameter _____ 34 mm
Max. line speed _____ 0-79 m/min



Auxiliary winch

Line pull effective (1st layer) _____ 100 kN
Rope diameter _____ 20 mm
Drum diameter _____ 400 mm
Max. line speed _____ 0-89 m/min



Rope crowd system

Crowd force push/pull _____ 400/400 kN
Line pull (effective) _____ 200 kN
Rope diameter _____ 28 mm
Travel _____ 18.5 m
Max. line speed _____ 0-70 m/min

The winches are noted for compact, easily mounted design. Propulsion is via a maintenance-free planetary gearbox in oil bath. Load support by the hydraulic system; additional safety factor by a spring-loaded, multi-disc holding brake. All line pull values are effective values. The efficiency factor of approx. 25% has already been deducted.



Noise emission

Noise emissions correspond with 2000/14/EC directive on noise emission by equipment used outdoors.

Process data recording system - PDE® (additional equipment)

The Liebherr process data recording system PDE® constantly records the relevant process data during the working process.

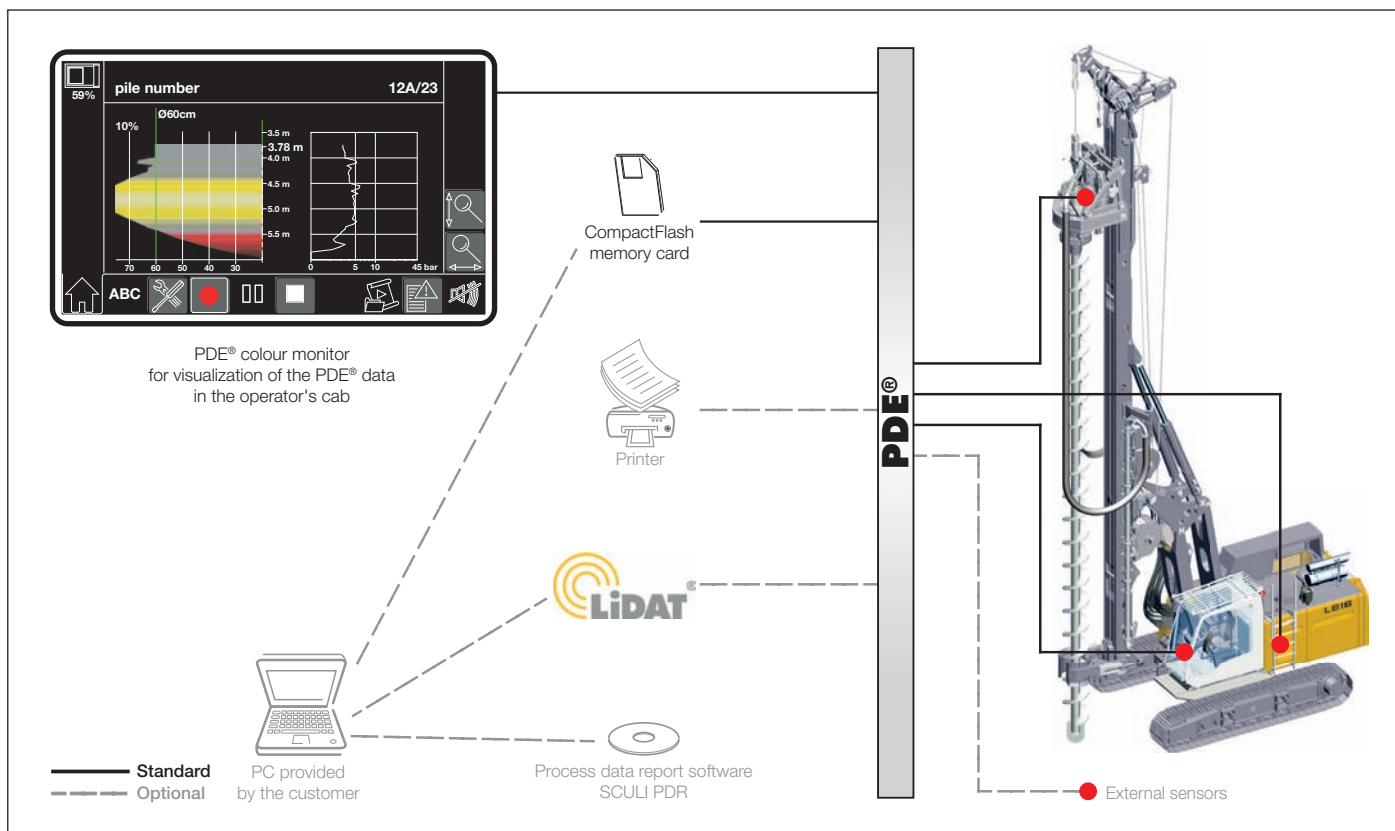

Depending on the application the recorded and processed data are displayed on the PDE® touchscreen in the operator's cab, e.g. in the form of an online cast-in-place pile.

At the same time the PDE® is operated using this touchscreen. The operator can enter various details (e.g. jobsite name, pile number, etc.) and start and stop recordings. A recording of every start-stop cycle carried out in the PDE® is established on a CompactFlash memory card.

The PDE® can be configured in a number of ways, e.g. for the connection of external sensors, for the generation of a simple protocol as graphic file and/or for a printout directly in the operator's cab.

Process data reporting - PDR (additional equipment)

Comprehensive data evaluation and generation of reports on a PC is possible using the software SCULI PDR.

Recordings management - The recordings generated by the PDE® system can be imported and managed in SCULI PDR. The data can be imported directly from the CompactFlash card or via the Liebherr telematics system LiDAT. Certain recordings, e.g. for a particular day or jobsite, can be found using filter functions.

Viewing data - The data in each record is displayed tabularly. Combining several recordings provides results, for example, regarding the total concrete consumption or the average depth. Furthermore, a diagram editor is available for quick analysis.

Generating reports - A vital element of SCULI PDR is the report generator, which allows for the generation of individual reports. These can be printed out directly or stored as pdf files. In the process the size, colour, line thickness or even the desired logo can be configured. Moreover, the reports can be displayed in different languages, e.g. in English and in the national language.

