

Technical data Hydraulic lift crane

LR 1300
Litronic®

Derrick equipment

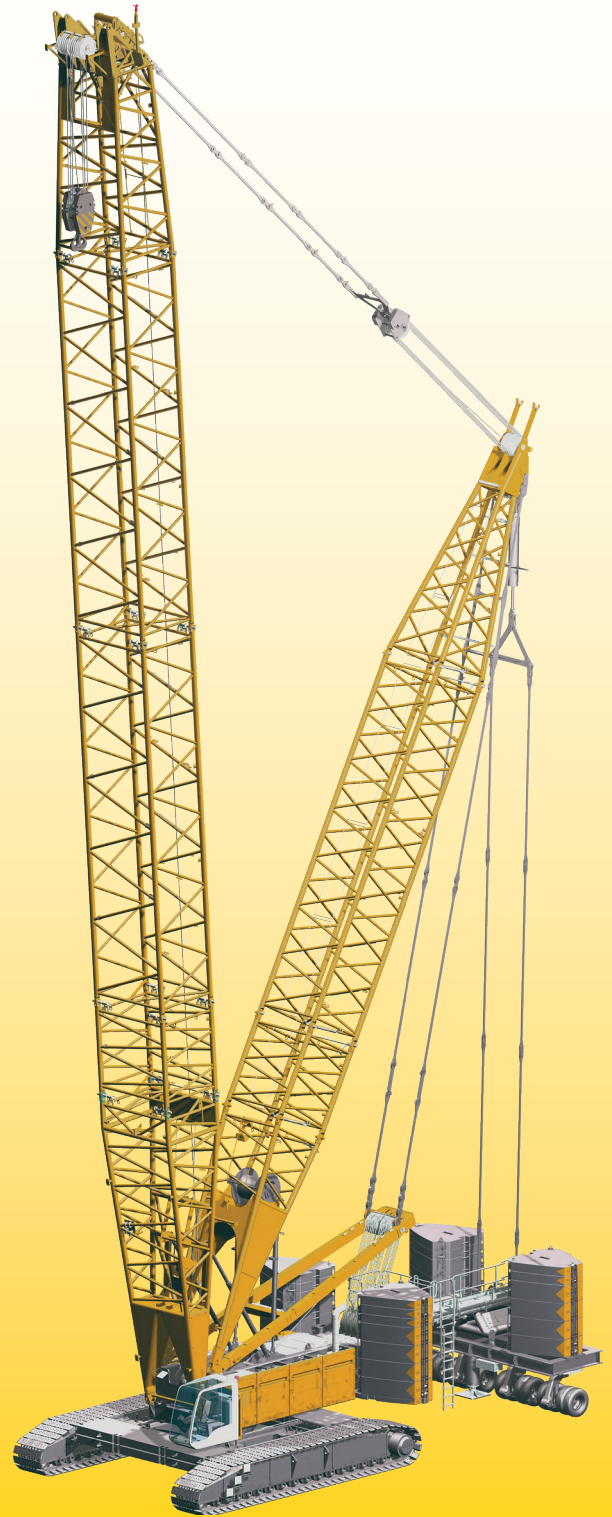

LIEBHERR

Dimensions

Basic machine with derrick equipment

Derrick equipment
with suspended counterweight

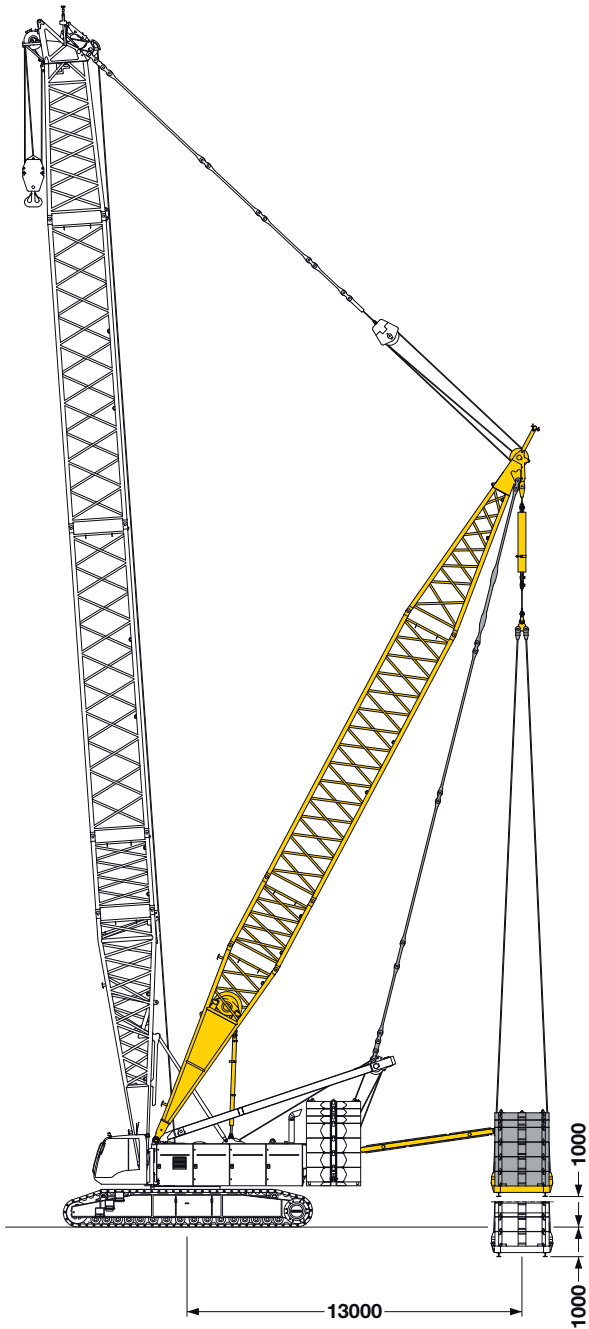

Derrick equipment
with wheeled counterweight carriage

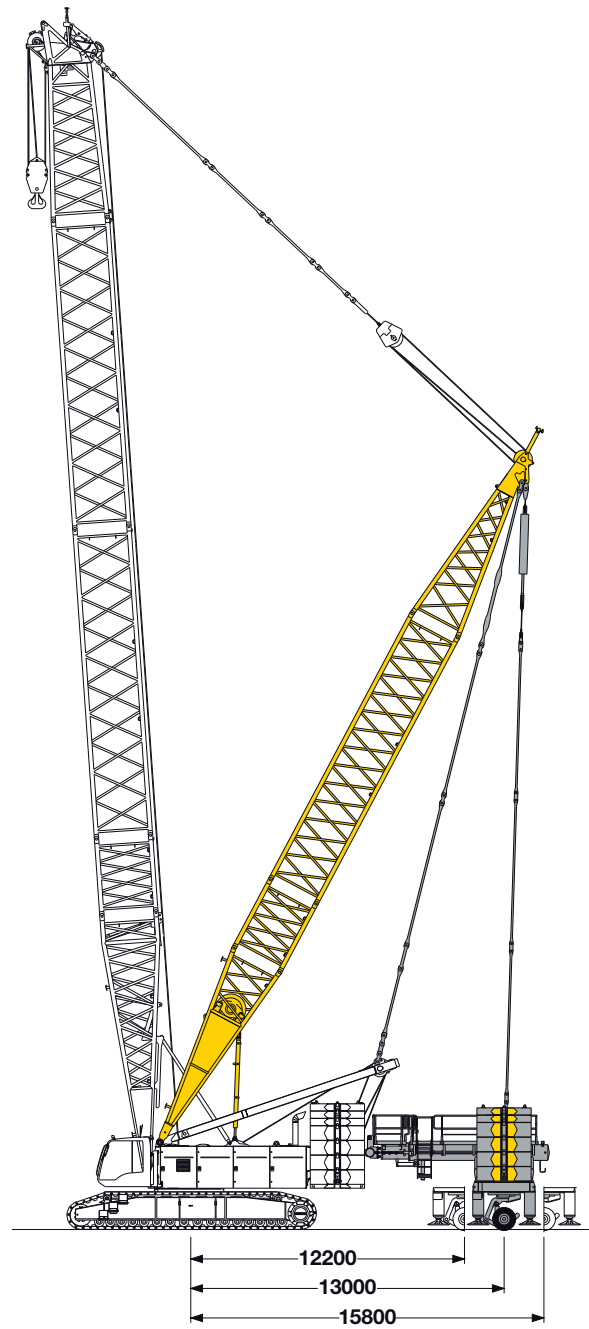

Transport dimensions and weights

Basic machine and boom (No. 2220.xx)

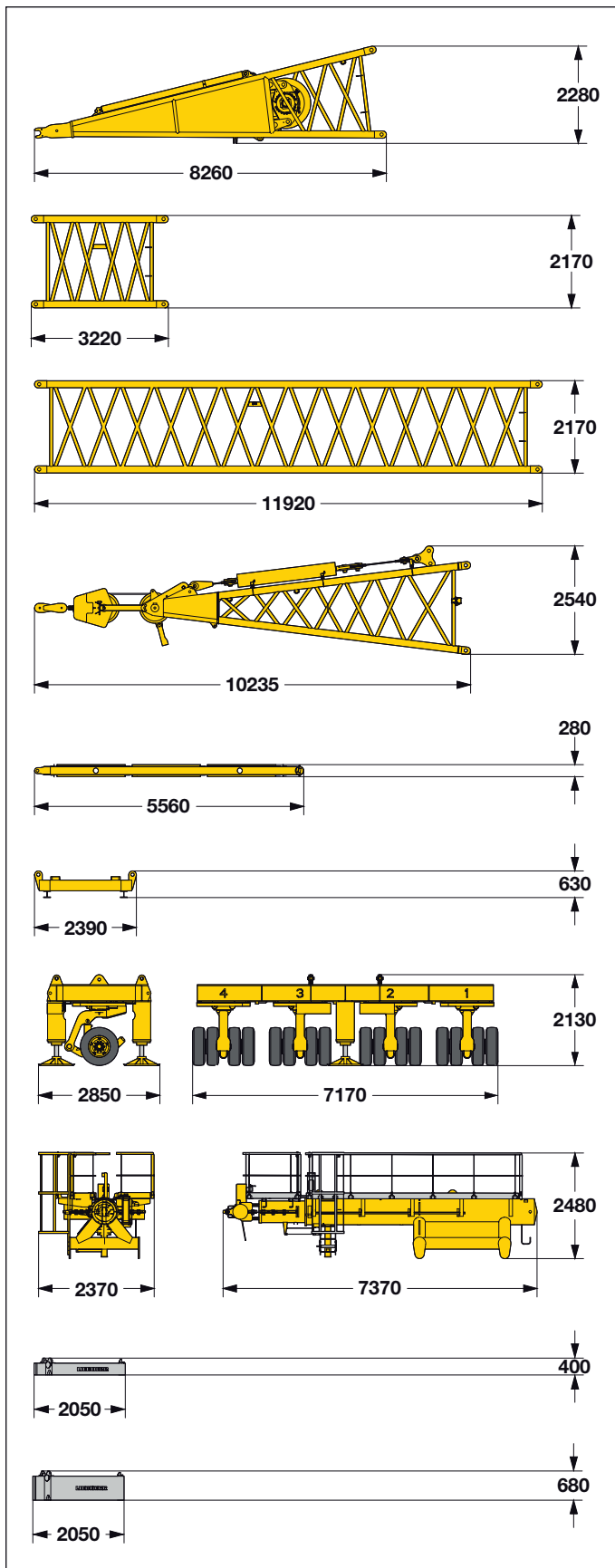

*) including pendant straps; **) including pendant ropes

Derrick foot (No. 2220.24)

Width	2420 mm
Weight incl. rope	7800 kg

Boom section (No. 2220.24)

Width	2420 mm
Weight*	1030 kg

Boom section (No. 2220.22)

Width	2420 mm
Weight*	2560 kg

Boom head (No. 2220.22)

Width	2420 mm
Weight*	5400 kg

Spacer frame

Width	2470 mm
Weight*	495 kg

Counterweight frame

Width	5050 mm
Weight**	14360 kg

Wheeled counterweight carriage

Width	2850 mm
Weight*	13155 kg

Telescopic unit

Width	2370 mm
Weight*	6645 kg

Counterweight (5 t)

Width	2120 mm
Weight*	5000 kg

Counterweight (10 t)

Width	2120 mm
Weight*	10000 kg

Working range - main boom (No.2821.xx) **86° - 15°**

124 t counterweight and 57 t carbody counterweight

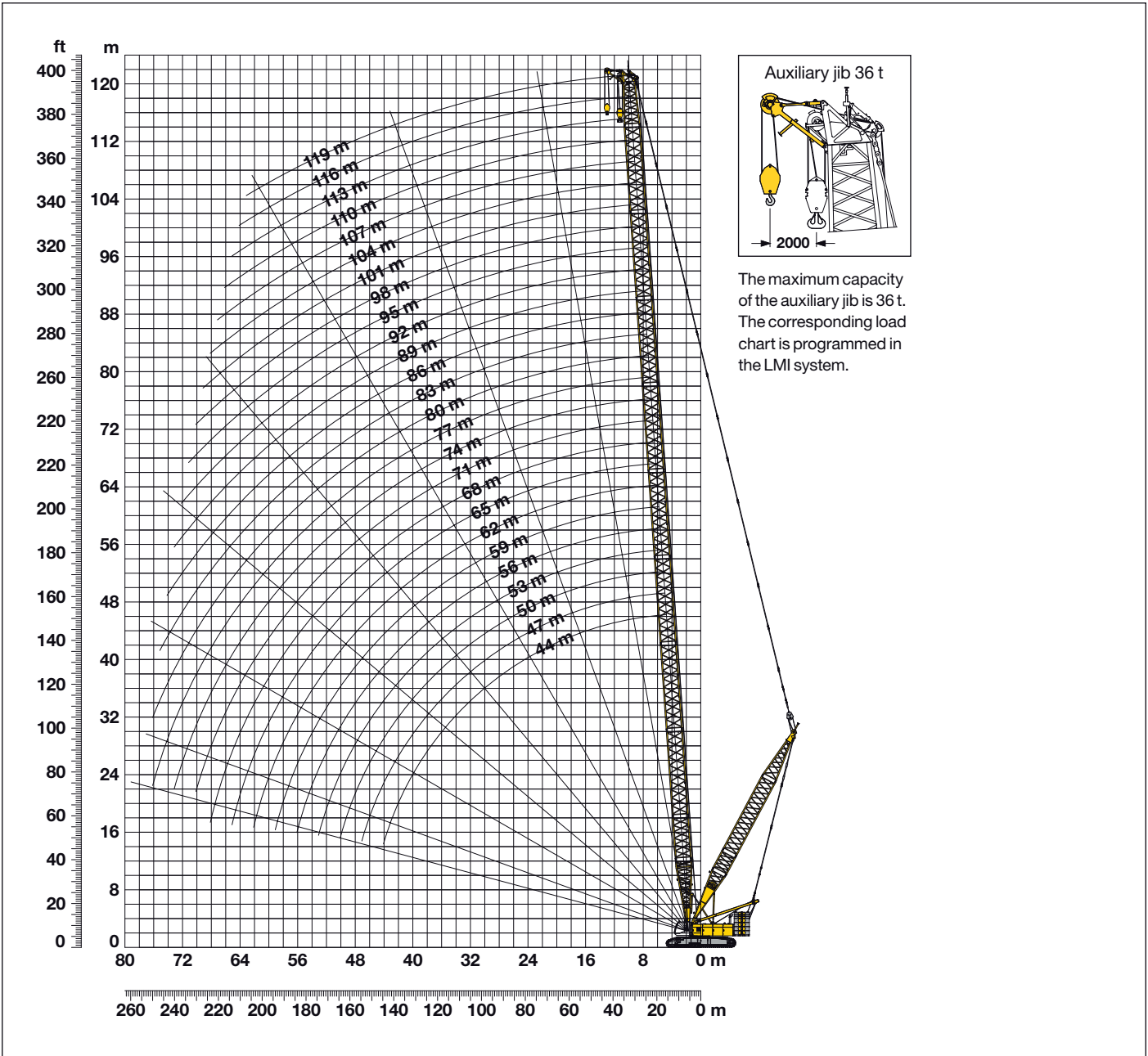

Main boom configuration (Table 1 – No. 2821.xx)

Configuration for boom lengths between 44 m and 119 m																											
	Length																										
Boom foot	10 m	1	1	1	1	1	1	1	1	1	1	1	1	1	1	1	1	1	1	1	1	1					
Boom section	3 m	1		1		1		1		1		1		1		1		1		1		1					
Boom section	6 m		1	1		1	1		1	1		1	1		1	1		1	1		1	1					
Boom section	12 m	2	2	2	3	3	3	3	4	4	4	4	5	5	5	5	6	6	6	6	7	7	7	7	8	8	8
Boom head	7 m	1	1	1	1	1	1	1	1	1	1	1	1	1	1	1	1	1	1	1	1	1	1	1	1	1	1
Boom length (m)		44	47	50	53	56	59	62	65	68	71	74	77	80	83	86	89	92	95	98	101	104	107	110	113	116	119

Lift chart - main boom (No. 2821.xx)

124 t counterweight and 57 t carbody counterweight

Capacities in metric tons for boom lengths (44 m - 119 m) - with 215 kN winches
124 t counterweight and 57 t carbody counterweight

Radius (m)	Boom length in (m)												Radius (m)
	44	50	56	68	74	86	92	98	104	110	113	119	
8.9	t	t	t	t	t	92.2	t	t	t	t	t	t	8.9
9				141.7	129.9	92.2							9
10				123.2	122.8	92.2	79.2	68.5					10
12	98.2	98.0	97.8	97.1	96.7	90.2	77.8	67.7	59.0	51.4	47.9	41.5	12
14	80.6	80.4	80.1	79.4	78.9	78.0	76.5	66.2	57.7	50.4	47.1	41.0	14
16	68.1	67.8	67.5	66.7	66.2	65.2	64.7	64.2	56.6	49.2	45.9	39.7	16
18	63.1	58.4	58.1	57.2	56.7	55.7	55.2	54.6	54.1	48.0	44.8	38.6	18
20	55.3	55.0	50.4	49.5	48.9	47.9	47.4	46.8	46.3	45.7	43.4	36.9	20
22	48.6	48.3	48.1	43.7	43.1	42.1	41.6	41.0	40.4	39.8	39.6	35.7	22
24	43.5	43.2	43.0	38.5	38.0	36.9	36.4	35.8	35.2	34.6	34.4	33.8	24
26	38.9	38.6	38.4	34.3	33.7	32.6	32.1	31.5	30.9	30.3	30.1	29.9	26
28	35.1	34.7	34.5	33.6	30.1	29.4	28.8	28.2	27.7	27.0	26.8	26.2	28
30	31.7	31.4	31.1	30.3	30.1	26.2	25.7	25.0	24.5	23.8	23.6	23.0	30
32	29.1	28.8	28.5	27.7	27.1	23.5	22.9	22.3	21.7	21.1	20.9	20.2	32
34	26.5	26.2	25.9	25.1	24.6	23.5	20.5	19.9	19.3	18.7	18.5	17.8	34
36	24.2	23.9	23.6	22.8	22.3	21.2	20.7	17.8	17.2	16.6	16.4	15.7	36
38	22.2	21.9	21.6	20.8	20.3	19.2	18.7	18.1	15.3	15.1	15.1	14.5	38
40	20.3	20.1	19.8	19.0	18.4	17.4	16.9	16.3	15.7	13.6	13.4	12.8	40
42	18.7	18.4	18.2	17.3	16.8	15.8	15.3	15.1	14.7	14.1	13.8	11.2	42
44	17.2	16.9	16.7	15.9	15.3	14.9	14.3	13.7	13.2	12.5	12.3	11.7	44
46		15.6	15.3	15.1	14.5	13.5	13.0	12.3	11.8	11.1	10.9	10.3	46
48		14.7	14.5	13.8	13.3	12.2	11.7	11.1	10.5	9.9	9.6	9.0	48
50		13.5	13.4	12.6	12.1	11.0	10.5	9.9	9.3	8.7	8.5	7.8	50
55			10.7	10.1	9.6	8.5	8.0	7.4	6.8	6.2	6.0	5.3	55
60				7.9	7.4	6.4	5.9	5.3	4.8	4.1	3.9	3.3	60
65				6.1	5.7	4.7	4.2	3.6	3.0	2.4	2.2		65
70					4.1	3.2	2.7	2.1					70

Above lift chart is for reference only.

For actual lift duty and complete chart with all available configurations please refer to lift chart in operator's cab or manual.

Lift chart - main boom (No. 2821.xx)

124 t counterweight and 57 t carbody counterweight and max. 120 t suspended counterweight at 13 m radius

Main boom 44 m

Radius	Suspended counterweight in metric tons at 13 m radius				
	0	50	75	90	120
(m)	t	t	t	t	t
12	98.2	157.6	187.0	204.8	236.6
14	80.6	130.5	155.2	170.1	199.8
16	68.1	110.8	132.1	144.9	170.7
18	63.1	100.8	119.4	130.8	153.2
20	55.3	88.6	105.2	115.4	135.3
22	48.6	78.8	93.9	102.9	121.0
24	43.5	70.9	84.6	92.7	109.2
26	38.9	64.1	76.7	84.3	99.4
28	35.1	58.5	70.1	77.0	90.9
30	31.7	53.5	64.3	70.9	83.8
32	29.1	49.2	59.5	65.4	77.5
34	26.5	45.4	55.0	60.6	72.1
36	24.2	42.2	51.1	56.5	67.2
38	22.2	39.2	47.6	52.7	62.8
40	20.3	36.5	44.6	49.3	59.0
42	18.7	34.0	41.7	46.2	55.4
44	17.2	31.8	39.1	43.4	50.8

Main boom 50 m

Radius	Suspended counterweight in metric tons at 13 m radius				
	0	50	75	90	120
(m)	(t)	(t)	(t)	(t)	(t)
11	109.3				
12	97.8	157.1	182.5	182.5	
14	80.1	129.9	154.7	169.5	175.6
16	67.5	110.2	131.4	144.4	168.7
18	58.1	95.4	114.2	125.4	147.8
20	50.4	83.9	100.6	110.5	130.6
22	48.1	78.2	93.3	102.5	120.4
24	43.0	70.3	84.0	92.1	108.6
26	38.4	63.5	76.0	83.7	98.8
28	34.5	57.9	69.5	76.4	90.3
30	31.1	52.9	63.7	70.3	83.2
32	28.5	48.6	58.9	64.8	76.9
34	25.9	45.0	54.4	60.0	71.5
36	23.6	41.7	50.5	55.9	66.6
38	21.6	38.6	47.0	52.1	62.2
40	19.8	36.0	44.1	48.7	58.4
42	18.2	33.5	41.2	45.7	54.9
44	16.7	31.3	38.6	43.0	51.7
46	15.3	29.4	36.3	40.5	48.7
48	14.5	27.5	34.2	38.2	46.0
50	13.4	25.8	32.2	36.0	43.7
55	10.7	22.0	27.8	31.3	38.2

Main boom 56 m

Radius	Suspended counterweight in metric tons at 13 m radius				
	0	50	75	90	120
(m)	t	t	t	t	t
11	109.3	174.9	187.1	187.1	
12	97.8	157.1	182.5	182.5	
14	80.1	129.9	154.7	169.5	175.6
16	67.5	110.2	131.4	144.4	168.7
18	58.1	95.4	114.2	125.4	147.8
20	50.4	83.9	100.6	110.5	130.6
22	48.1	78.2	93.3	102.5	120.4
24	43.0	70.3	84.0	92.1	108.6
26	38.4	63.5	76.0	83.7	98.8
28	34.5	57.9	69.5	76.4	90.3
30	31.1	52.9	63.7	70.3	83.2
32	28.5	48.6	58.9	64.8	76.9
34	25.9	45.0	54.4	60.0	71.5
36	23.6	41.7	50.5	55.9	66.6
38	21.6	38.6	47.0	52.1	62.2
40	19.8	36.0	44.1	48.7	58.4
42	18.2	33.5	41.2	45.7	54.9
44	16.7	31.3	38.6	43.0	51.7
46	15.3	29.4	36.3	40.5	48.7
48	14.5	27.5	34.2	38.2	46.0
50	13.4	25.8	32.2	36.0	43.7
55	10.7	22.0	27.8	31.3	38.2

Main boom 68 m

Radius	Suspended counterweight in metric tons at 13 m radius				
	0	50	75	90	120
(m)	(t)	(t)	(t)	(t)	(t)
9	141.7				
10	123.2	144.5	144.5		
12	97.1	139.4	139.4	139.4	
16	66.7	109.4	130.8	131.4	131.4
18	57.2	94.5	113.3	124.5	126.2
20	49.5	83.0	99.7	109.6	121.8
22	43.7	73.8	88.6	97.7	115.6
24	38.5	65.9	79.6	88.0	104.2
26	34.3	59.7	72.2	79.6	94.7
28	33.6	57.1	68.6	75.5	89.4
30	30.3	52.1	62.8	69.4	82.3
32	27.7	47.7	58.0	63.9	76.0
34	25.1	44.2	53.6	59.3	70.6
36	22.8	40.8	49.6	55.1	65.7
38	20.8	37.8	46.2	51.3	61.3
40	19.0	35.1	43.2	47.9	57.6
44	15.9	30.5	37.8	42.2	50.8
48	13.8	26.8	33.4	37.4	45.2
50	12.6	25.1	31.4	35.2	42.9
55	10.1	21.4	27.2	30.6	37.6
60	7.9	18.3	23.6	26.8	33.1
65	6.1	15.7	20.5	23.5	29.3

Above lift chart is for reference only.

For actual lift duty and complete chart with all available configurations please refer to lift chart in operator's cab or manual.

Lift chart – main boom (No. 2821.xx)

124 t counterweight and 57 t carbody counterweight and max. 120 t suspended counterweight at 13 m radius

Main boom 74 m

Radius	Suspended counterweight in metric tons at 13 m radius				
	0	50	75	90	120
(m)	(t)	(t)	(t)	(t)	(t)
9	129.9				
10	122.8	129.9			
12	96.7	126.9	122.1		
14	78.9	122.1	118.0	118.0	
18	56.7	108.9	111.6	111.6	111.6
20	48.9	94.0	99.1	107.3	107.3
22	43.1	82.4	88.2	97.2	103.6
24	38.0	73.2	79.1	87.4	100.6
26	33.7	65.4	71.7	79.1	94.2
28	30.1	59.1	65.2	72.2	86.1
30	30.1	53.6	62.3	68.9	81.8
32	27.1	51.6	57.5	63.4	75.5
34	24.6	47.2	53.0	58.8	70.1
36	22.3	43.7	49.1	54.5	65.2
38	20.3	40.3	45.6	50.7	60.8
40	18.4	37.3	42.7	47.4	57.1
44	15.3	32.2	37.3	41.7	50.3
48	13.3	28.1	32.8	36.9	44.9
55	9.6	24.6	26.7	30.1	37.1
60	7.4	20.9	23.1	26.3	32.6
65	5.7	17.8	20.1	23.0	28.9
70	4.1	15.2	17.5	20.2	25.6

Main boom 86 m

Radius	Suspended counterweight in metric tons at 13 m radius				
	0	50	75	90	120
(m)	(t)	(t)	(t)	(t)	(t)
8.9	92.2				
12	90.2	90.2			
16	65.2	86.0	86.0		
18	55.7	84.2	84.2	84.2	
24	36.9	64.3	76.4	76.4	76.4
26	32.6	58.1	70.6	74.1	74.1
28	29.4	52.5	64.1	70.9	72.2
30	26.2	47.7	58.7	65.0	71.5
32	23.5	43.9	53.8	59.8	71.3
34	23.5	42.6	52.0	57.7	69.0
36	21.2	39.2	48.1	53.5	64.1
38	19.2	36.2	44.8	49.7	59.8
40	17.4	33.5	41.7	46.3	56.0
44	14.9	29.1	36.3	40.7	49.3
48	12.2	25.2	31.8	35.8	43.9
55	8.5	19.9	25.7	29.2	36.1
60	6.4	16.8	22.1	25.3	31.6
65	4.7	14.6	19.1	22.1	28.0
70	3.2	12.3	16.6	19.3	24.7
75		10.4	14.6	16.9	21.9
80		8.6	12.6	15.0	19.5
85		7.1	10.8	13.0	17.3

Main boom 92 m

Radius	Suspended counterweight in metric tons at 13 m radius				
	0	50	75	90	120
(m)	(t)	(t)	(t)	(t)	(t)
9.3	79.2				
12	77.8	77.8			
18	55.2	72.8	72.8		
20	47.4	71.6	71.6	71.6	
28	28.8	52.0	62.5	62.5	62.5
30	25.7	47.2	58.2	60.9	60.9
32	22.9	43.3	53.3	59.2	60.3
34	20.5	39.7	49.0	54.8	59.9
36	20.7	38.7	47.5	53.0	59.6
38	18.7	35.7	44.3	49.2	59.1
40	16.9	33.0	41.1	45.8	55.5
44	14.3	28.6	35.7	40.1	48.7
48	11.7	24.7	31.3	35.3	43.3
50	10.5	23.0	29.5	33.2	40.9
55	8.0	19.4	25.2	28.7	35.5
60	5.9	16.3	21.6	24.8	31.1
65	4.2	14.1	18.6	21.6	27.5
70	2.7	11.9	16.1	18.8	24.2
75		9.9	14.2	16.4	21.4
80		8.2	12.2	14.6	19.0
85		6.7	10.4	12.6	16.8
90		5.3	8.8	10.9	14.9

Main boom 98 m

Radius	Suspended counterweight in metric tons at 13 m radius				
	0	50	75	90	120
(m)	(t)	(t)	(t)	(t)	(t)
9.7	68.5				
14	66.2	66.2			
20	46.8	62.0	62.0		
22	41.0	60.1	60.1	60.1	
30	25.0	46.6	57.6	58.0	58.0
32	22.3	42.7	52.7	57.9	57.9
34	19.9	39.0	48.4	54.2	57.9
36	17.8	35.8	44.9	50.1	57.9
38	18.1	35.1	43.7	48.6	57.9
40	16.3	32.4	40.5	45.2	54.9
44	13.7	28.0	35.1	39.5	48.1
48	11.1	24.1	30.7	34.7	42.7
50	9.9	22.4	28.9	32.6	40.3
55	7.4	18.8	24.6	28.1	34.9
60	5.3	15.7	21.0	24.2	30.5
65	3.6	13.5	18.1	21.0	26.9
70	2.1	11.3	15.5	18.2	23.7
75		9.3	13.6	15.8	20.9
80		7.6	11.6	14.0	18.4
85		6.1	9.9	12.1	16.3
90		4.8	8.3	10.4	14.6
95		3.5	6.8	8.8	12.8

Above lift chart is for reference only.

For actual lift duty and complete chart with all available configurations please refer to lift chart in operator's cab or manual.

Lift chart - main boom (No. 2821.xx)

124 t counterweight and 57 t carbody counterweight and max. 120 t suspended counterweight at 13 m radius

Main boom 104 m

Radius	Suspended counterweight in metric tons at 13 m radius				
	0	50	75	90	120
(m)	t	t	t	t	t
12	59.0				
14	57.7	57.7			
22	40.4	52.5	52.5		
26	30.9	50.3	50.3	50.3	
32	21.7	42.1	50.1	50.1	50.1
34	19.3	38.5	47.9	50.1	50.1
36	17.2	35.3	44.3	49.5	50.1
38	15.3	32.4	41.0	45.9	50.1
40	15.7	31.9	40.0	44.8	50.1
44	13.2	27.4	34.6	39.0	47.6
48	10.5	23.6	30.1	34.1	42.2
50	9.3	21.9	28.3	32.0	39.7
55	6.8	18.2	24.0	27.6	34.4
60	4.8	15.2	20.5	23.7	30.0
65	3.0	13.0	17.5	20.5	26.3
70		10.7	15.1	17.7	23.1
75		8.8	13.1	15.3	20.3
80		7.1	11.1	13.5	17.9
85		5.6	9.3	11.6	15.8
90		4.3	7.8	9.9	14.1
95		3.0	6.4	8.4	12.4
100			5.1	7.0	10.8

Main boom 110 m

Radius	Suspended counterweight in metric tons at 13 m radius				
	0	50	75	90	120
(m)	(t)	(t)	(t)	(t)	(t)
10.6	51.4				
16	49.2	49.2			
24	34.6	44.6	44.6		
28	27.0	43.1	43.1	43.1	
36	16.6	34.6	42.7	42.7	42.7
38	15.1	31.8	40.3	42.7	42.7
40	13.6	29.4	37.3	42.0	42.7
44	12.5	26.8	34.0	38.4	42.7
46	11.1	24.8	31.6	35.8	42.7
48	9.9	22.9	29.7	33.5	41.5
50	8.7	21.2	27.7	31.4	39.1
55	6.2	17.6	23.4	26.9	33.8
60	4.1	15.0	19.9	23.1	29.5
65	2.4	12.4	16.9	19.8	25.7
70		10.1	14.7	17.1	22.5
75		8.2	12.5	15.0	19.7
80		6.5	10.5	12.9	17.3
85		5.0	8.7	11.0	15.2
90		3.7	7.2	9.3	13.5
95		2.5	5.8	7.8	11.8
100			4.5	6.4	10.2
105			3.4	5.2	8.8

Main boom 113 m

Radius	Suspended counterweight in metric tons at 13 m radius				
	0	50	75	90	120
(m)	(t)	(t)	(t)	(t)	(t)
10.8	47.9				
16	45.9	45.9			
24	34.4	41.3	41.3		
30	23.6	39.4	39.4	39.4	
38	15.1	31.5	38.9	38.9	38.9
40	13.4	29.2	37.1	38.9	38.9
44	12.3	26.6	33.7	38.0	38.9
46	10.9	24.6	31.4	35.6	38.9
48	9.6	22.7	29.5	33.3	38.9
50	8.5	21.0	27.5	31.2	38.7
55	6.0	17.4	23.2	26.7	33.6
60	3.9	14.8	19.7	22.9	29.3
65	2.2	12.1	16.7	19.6	25.5
70		9.9	14.5	16.9	22.3
75		8.0	12.2	14.8	19.5
80		6.3	10.3	12.7	17.1
85		4.8	8.5	10.8	15.0
90		3.5	7.0	9.1	13.3
95		2.3	5.6	7.6	11.6
100			4.3	6.2	10.0
105			3.2	5.0	8.6
110			2.1	3.8	7.3

Main boom 119 m

Radius	Suspended counterweight in metric tons at 13 m radius				
	0	50	75	90	120
(m)	(t)	(t)	(t)	(t)	(t)
11.2	41.5				
18	38.6	38.6			
28	26.2	33.4	33.4		
32	20.2	32.6	32.6	32.6	
42	11.2	26.2	31.9	31.9	31.9
44	11.7	25.9	31.9	31.9	31.9
46	10.3	23.9	30.8	31.9	31.9
48	9.0	22.1	28.8	31.9	31.9
50	7.8	20.4	26.9	30.6	31.9
55	5.3	16.7	22.6	26.1	31.9
60	3.3	14.1	19.0	22.2	28.6
65		11.5	16.1	19.0	24.9
70		9.3	13.9	16.2	21.7
75		7.3	11.6	14.2	18.9
80		5.7	9.7	12.1	16.5
85		4.2	7.9	10.2	14.4
90		2.9	6.4	8.5	12.5
95			5.0	7.0	10.8
100			3.8	5.7	9.3
105			2.6	4.4	7.9
110				3.3	6.6
115				2.2	2.6

Above lift chart is for reference only.

For actual lift duty and complete chart with all available configurations please refer to lift chart in operator's cab or manual.

Lift chart - main boom (No. 2821.xx)

124 t counterweight and 57 t carbody counterweight and 120 t wheeled counterweight carriage at 15.8 m radius

Capacities in metric tons for boom lengths (44 m - 119 m) - with 215 kN winches
124 t counterweight and 57 t carbody counterweight and 120 t wheeled counterweight carriage

Radius (m)	Boom length in (m)											Radius (m)				
	44	50	56	68	74	86	92	98	104	110	113		119			
	t	t	t	t	t	t	t	t	t	t	t	t	t			
8.9						92.2								8.9		
9				147.9	129.9	92.2								9		
10				144.5	126.9	92.2	79.2	68.5						10		
12	236.6	211.2	182.5	139.4	122.1	90.2	77.8	67.7	59.0	51.4	47.9	41.5		12		
14	219.4	201.0	175.6	134.7	118.0	88.4	76.5	66.2	57.7	50.4	47.1	41.0		14		
16	188.8	188.3	168.7	131.4	114.9	86.0	74.5	64.9	56.6	49.2	45.9	39.7		16		
18	169.1	164.1	163.2	126.2	111.6	84.2	72.8	63.3	55.1	48.0	44.8	38.6		18		
20	149.6	149.3	144.7	121.8	107.3	82.3	71.6	62.0	53.9	46.7	43.4	36.9		20		
22	133.8	133.5	133.2	118.2	103.6	79.1	69.2	60.1	52.5	45.7	42.4	35.7		22		
24	120.9	120.6	120.3	114.9	100.6	76.4	66.6	58.7	51.2	44.6	41.3	34.8		24		
26	110.1	109.8	109.5	105.4	98.1	74.1	64.4	58.2	50.3	43.7	40.4	34.0		26		
28	101.0	100.5	100.3	99.5	95.6	72.2	62.5	58.0	50.1	43.1	39.7	33.4		28		
30	93.0	92.7	92.4	91.5	91.0	71.5	60.9	58.0	50.1	42.9	39.4	32.9		30		
32	86.2	85.9	85.6	84.7	84.2	71.3	60.3	57.9	50.1	42.8	39.3	32.6		32		
34	80.1	79.8	79.5	78.6	78.1	71.1	59.9	57.9	50.1	42.7	39.1	32.4		34		
36	74.7	74.4	74.2	73.2	72.9	71.0	59.6	57.9	50.1	42.7	39.0	32.1		36		
38	70.0	69.7	69.5	68.6	68.1	67.0	59.3	57.9	50.1	42.7	38.9	31.9		38		
40	65.7	65.4	65.2	64.3	63.8	62.7	59.0	57.9	50.1	42.7	38.9	31.9		40		
42	61.8	61.5	61.3	60.4	59.9	59.0	58.2	57.7	50.1	42.7	38.9	31.9		42		
44	58.1	58.1	57.9	57.1	56.5	55.5	55.0	54.4	50.1	42.7	38.9	31.9		44		
46		54.9	54.7	53.9	53.3	52.3	51.8	51.2	49.2	42.7	38.9	31.9		46		
48		51.9	51.7	50.9	50.4	49.4	48.9	48.3	47.7	42.4	38.9	31.9		48		
50		49.2	49.0	48.2	47.7	46.7	46.2	45.6	45.0	42.1	38.9	31.9		50		
55			43.2	42.5	42.0	41.0	40.5	39.9	39.4	38.7	38.4	31.9		55		
60				37.6	37.1	36.2	35.6	35.1	34.5	33.9	33.7	31.9		60		
65				33.5	33.0	32.1	31.6	31.0	30.4	29.8	29.6	29.0		65		
70					29.5	28.6	28.1	27.5	27.0	26.4	26.2	25.5		70		
75						25.5	25.0	24.5	23.9	23.3	23.1	22.3		75		
80							22.8	22.4	21.8	21.3	20.7	20.5	19.4		80	
85								20.4	20.0	19.5	18.9	18.3	18.1	16.5		85
90									17.9	17.4	16.9	16.3	16.1	14.1		90
95										15.4	15.0	14.4	14.2	12.3		95
100											13.4	12.7	12.5	10.7		100
105												11.3	11.0	9.4		105
110													9.6	6.6		110
115														2.6		115

Above lift chart is for reference only.

For actual lift duty and complete chart with all available configurations please refer to lift chart in operator's cab or manual.

Lift chart - luffing jib (No. 2316.xx)

Main boom angle 88°

Main boom 44 m

Radius	Jib length in (m)							
	41	53	65	77	89	95	101	113
(m)	t	t	t	t	t	t	t	t
13.2	66.3							
16	58.4	47.0						
19	46.4	43.2	32.7					
22	38.1	35.9	31.0	23.0				
24	32.8	31.1	29.0	22.3	16.3			
26	30.2	28.6	26.4	21.7	16.0	13.7	11.7	
30	25.3	23.5	22.2	19.4	15.4	13.2	11.4	8.2
34	22.2	20.7	19.0	17.1	14.6	12.7	11.0	7.9
38	19.1	17.8	16.5	14.9	13.5	12.2	10.5	7.5
40	18.3	16.8	15.6	13.7	12.6	11.7	10.3	7.3
42	17.4	16.0	14.6	12.7	11.8	11.0	10.0	7.2
55		11.1	9.9	8.3	7.4	6.7	6.1	4.8
65			7.5	6.1	5.0	4.3	3.9	2.8
75				4.6	3.3	2.9	2.3	
80					2.6	2.1		
85					2.1			

Main boom 50 m

Radius	Jib length in (m)							
	41	53	65	77	89	95	101	113
(m)	t	t	t	t	t	t	t	t
13.4	61.5							
16	54.5	44.5						
19	44.1	40.7	31.2					
22	36.5	33.8	29.6	22.0				
24	31.7	29.5	27.6	21.5	15.7			
26	29.0	27.2	25.1	20.8	15.5	13.2	11.3	
30	24.5	22.6	21.0	18.5	15.0	12.8	11.1	8.0
34	21.5	20.0	18.1	16.2	13.8	12.2	10.6	7.6
38	18.7	17.2	15.8	14.1	12.6	11.5	10.1	7.3
40	17.8	16.2	14.9	13.0	11.8	11.0	9.8	7.1
42	16.9	15.5	14.0	12.0	11.0	10.3	9.5	6.9
44	15.8	14.6	13.0	11.4	10.2	9.6	8.9	6.8
55		10.8	9.5	7.9	7.0	6.3	5.7	4.5
65			7.3	5.9	4.7	4.1	3.7	2.5
75				4.3	3.1	2.7	2.2	
80					2.5			

Main boom 62 m

Radius	Jib length in (m)							
	41	53	65	77	89	95	101	113
(m)	t	t	t	t	t	t	t	t
13.9	50.7							
17	43.9	36.9						
19	38.7	34.8	26.9					
22	32.5	29.6	25.6	19.3				
24	28.8	26.1	23.8	19.0	14.0			
26	26.2	24.1	21.8	18.4	13.9	11.9		
28	24.4	22.3	19.7	17.6	13.8	11.8	10.1	
30	22.5	20.4	18.2	16.4	13.6	11.7	10.1	7.0
34	19.7	18.0	15.9	14.2	12.3	11.1	9.8	6.8
42	15.7	14.0	12.3	10.7	9.5	8.8	8.0	6.0
44	14.8	13.3	11.5	10.1	8.9	8.2	7.5	5.7
55		10.0	8.4	7.1	6.0	5.4	4.7	3.5
60			7.3	6.2	4.9	4.4	3.8	2.5
65			6.5	5.3	4.1	3.4	3.0	
70				4.4	3.4	2.7	2.1	
75				3.9	2.7	2.1		

Main boom 74 m

Radius	Jib length in (m)							
	41	53	65	77	89	95	101	113
(m)	t	t	t	t	t	t	t	t
14.3	39.7							
17	37.5	29.5						
20	31.8	27.9	21.5					
22	28.8	25.6	21.0	15.7				
26	23.5	21.2	18.7	15.2	11.3	9.7		
28	22.0	19.7	17.1	14.8	11.3	9.6	8.1	
30	20.5	18.2	15.9	13.9	11.2	9.6	8.1	5.3
34	18.0	16.1	14.0	12.2	10.2	9.1	7.9	5.3
38	16.0	14.2	12.2	10.8	9.1	8.2	7.2	5.1
40	15.0	13.3	11.6	10.1	8.6	7.7	6.8	4.8
42	14.4	12.7	10.9	9.3	8.0	7.2	6.4	4.6
44	13.7	12.1	10.3	8.8	7.5	6.8	6.0	4.3
55		9.1	7.6	6.1	5.0	4.4	3.7	2.5
65			5.8	4.5	3.3	2.7	2.2	
70				3.8	2.7	2.1		
75				3.3	2.1			

Main boom 80 m

Radius	Jib length in (m)							
	41	53	65	77	89	95	101	113
(m)	t	t	t	t	t	t	t	t
14.5	35.0							
17	33.7	26.1						
20	29.1	25.1	19.1					
22	26.4	23.5	18.6	14.0				
26	21.7	19.8	16.9	13.6	10.1	8.5		
28	20.4	18.5	15.8	13.3	10.0	8.5	7.1	
30	19.0	17.2	14.7	12.6	9.9	8.4	7.0	4.5
34	16.8	15.2	13.0	11.3	9.2	8.1	6.9	4.4
38	15.0	13.4	11.4	10.0	8.3	7.3	6.3	4.3
42	13.6	12.0	10.2	8.7	7.3	6.5	5.7	3.8
44	12.9	11.4	9.6	8.1	6.8	6.1	5.3	3.6
50		9.6	8.1	6.8	5.4	4.7	4.1	2.7
60			6.1	4.9	3.6	3.1	2.5	
65			5.4	4.2	2.9	2.3		
70				3.4	2.3			
75				3.0				

Main boom 86 m

Radius	Jib length in (m)							
	41	53	65	77	89	95	101	113
(m)	t	t	t	t	t	t	t	t
14.7	30.8							
18	29.0	22.8						
20	26.8	22.0	16.8					
24	22.4	19.1	15.9	12.2				
26	20.3	17.7	15.2	12.0	8.7	7.3		
28	19.2	16.6	14.4	11.7	8.7	7.3	6.0	
30	17.9	15.5	13.6	11.3	8.6	7.2	6.0	3.6
34	15.8	13.7	12.1	10.3	8.1	7.0	5.8	3.5
38	14.2	12.1	10.6	9.1	7.4	6.4	5.4	3.4
42	12.8	10.9	9.5	7.9	6.5	5.8	5.0	3.1
44	12.2	10.4	8.9	7.4	6.1	5.4	4.6	2.9
50		8.8	7.5	6.2	4.8	4.1	3.5	2.2
60			5.6	4.5	3.2	2.6	2.0	
65			5.0	3.8	2.5			
70				3.0				
75				2.6				

Capacities in metric tons with luffing jib (No. 2316.xx), 124 t counterweight + 57 t carbody counterweight. Above lift chart is for reference only. For actual lift duty and complete chart with all available configurations please refer to lift chart in operator's cab or manual.

Lift chart – luffing jib (No. 2316.xx)

Main boom angle 83°

Main boom 44 m

Radius	Jib length in (m)							
	41	53	65	77	89	95	101	113
(m)	t	t	t	t	t	t	t	t
20.6	50.5							
26	38.3	37.3						
28	35.0	34.0	29.6					
32	29.7	29.1	28.2	21.0				
36	25.9	25.0	24.1	20.4	15.1			
38	24.2	23.3	22.4	20.0	14.9	12.6		
40	22.6	21.8	20.9	19.6	14.7	12.5	10.6	
42	21.2	20.4	19.5	18.6	14.4	12.2	10.5	7.3
44	20.0	19.2	18.3	17.4	14.1	12.0	10.3	7.3
46	18.8	18.0	17.2	16.3	13.8	11.7	10.1	7.1
55		14.0	13.2	12.3	11.4	10.6	9.3	6.5
70			8.8	8.0	7.2	6.8	6.3	5.2
80				5.8	5.0	4.9	4.4	3.5
85					4.1	3.7	3.6	2.8
90					3.4	2.9	2.4	2.1
95						2.3		

Main boom 50 m

Radius	Jib length in (m)							
	41	53	65	77	89	95	101	113
(m)	t	t	t	t	t	t	t	t
21.3	47.7							
26	37.7	36.7						
30	31.6	30.7	28.2					
32	29.2	28.6	27.6	20.2				
36	25.5	24.6	23.6	19.8	14.6			
38	23.8	22.9	22.0	19.4	14.5	12.2		
40	22.3	21.4	20.5	19.0	14.3	12.1	10.3	
44	19.6	18.8	17.9	17.0	13.8	11.7	10.1	7.0
46	18.5	17.7	16.8	15.9	13.5	11.4	9.9	7.0
48	17.4	16.7	15.8	14.9	13.2	11.2	9.7	6.8
60		12.0	11.3	10.4	9.5	9.1	8.4	6.0
70			8.6	7.8	7.0	6.5	6.1	4.9
80				5.9	5.0	4.7	4.2	3.3
85					4.1	3.7	3.4	2.5
90					3.4	2.9	2.4	
95						2.3		

Main boom 62 m

Radius	Jib length in (m)							
	41	53	65	77	89	95	101	113
(m)	t	t	t	t	t	t	t	t
22.7	42.8							
28	33.2	32.2						
30	30.5	29.6	25.5					
34	26.4	25.4	24.4	18.3				
38	22.9	22.0	21.0	17.8	13.4			
40	21.4	20.5	19.6	17.5	13.3	11.2		
42	20.1	19.2	18.3	17.0	13.0	11.1	9.6	
44	18.9	18.0	17.1	16.1	12.8	10.9	9.5	6.5
46	17.8	17.0	16.0	15.1	12.5	10.7	9.3	6.5
48	16.8	16.0	15.1	14.1	12.3	10.5	9.1	6.4
60		11.5	10.7	9.8	8.9	8.4	7.9	5.5
70			8.1	7.3	6.4	6.0	5.5	4.5
80				5.4	4.6	4.2	3.7	2.8
85					3.7	3.4	3.0	2.1
90					3.1	2.5	2.2	
95					2.3	2.0		

Main boom 74 m

Radius	Jib length in (m)							
	41	53	65	77	89	95	101	113
(m)	t	t	t	t	t	t	t	t
24.2	36.4							
28	31.8	27.7						
32	27.2	26.2	21.0					
36	23.4	22.5	20.5	15.8				
40	20.4	19.5	18.5	15.4	11.7	10.0		
42	19.2	18.2	17.3	15.3	11.6	9.9	8.4	
46	17.0	16.1	15.1	14.0	11.3	9.7	8.3	5.5
48	16.0	15.1	14.2	13.2	11.0	9.5	8.1	5.4
50	15.1	14.3	13.4	12.4	10.6	9.3	8.0	5.4
60		10.8	10.0	9.1	8.1	7.7	7.1	4.9
65			8.7	7.8	6.9	6.4	5.9	4.6
70			7.6	6.7	5.7	5.3	4.9	3.9
80				4.9	4.0	3.6	3.1	2.1
85				4.2	3.1	2.8	2.4	
90					2.6			
95					2.0			

Main boom 80 m

Radius	Jib length in (m)							
	41	53	65	77	89	95	101	113
(m)	t	t	t	t	t	t	t	t
24.9	32.0							
30	28.4	24.6						
32	26.6	24.2	18.7					
36	22.8	21.7	18.3	14.2				
40	19.9	18.9	17.2	13.9	10.4			
42	18.7	17.7	16.2	13.7	10.4	8.8		
44	17.5	16.6	15.2	13.3	10.2	8.7	7.3	
46	16.4	15.5	14.4	12.7	10.1	8.7	7.3	4.7
48	15.6	14.6	13.6	12.2	10.0	8.6	7.2	4.6
50	14.7	13.9	12.8	11.6	9.6	8.5	7.1	4.6
60		10.5	9.6	8.5	7.6	7.0	6.2	4.1
65			8.2	7.4	6.4	5.9	5.4	3.8
75			6.2	5.3	4.4	3.8	3.3	2.5
80				4.6	3.6	3.2	2.6	
85				3.9	2.8	2.5	2.0	
90					2.3			

Main boom 86 m

Radius	Jib length in (m)							
	41	53	65	77	89	95	101	113
(m)	t	t	t	t	t	t	t	t
25.7	28.3							
30	26.9	21.6						
34	23.6	20.8	16.4					
38	20.5	18.5	16.1	12.5				
40	19.2	17.4	15.6	12.3	9.1			
42	18.0	16.5	14.8	12.2	9.1	7.6		
44	16.9	15.5	14.1	11.9	9.0	7.6	6.3	
48	15.0	13.6	12.7	11.0	8.8	7.5	6.2	3.8
50	14.1	13.0	12.0	10.5	8.5	7.4	6.1	3.8
55		11.3	10.2	9.2	7.7	6.8	5.8	3.6
60		10.0	9.0	7.8	6.8	6.1	5.2	3.4
65			7.8	6.7	5.7	5.2	4.6	3.0
70			6.9	5.8	4.5	4.2	3.7	2.6
75			6.0	4.9	3.9	3.2	2.8	
80				4.2	3.2	2.7	2.1	
85				3.6	2.4	2.1		

Capacities in metric tons with luffing jib (No. 2316.xx), 124 t counterweight + 57 t carbody counterweight. Above lift chart is for reference only. For actual lift duty and complete chart with all available configurations please refer to lift chart in operator's cab or manual.

Lift chart - luffing jib (No. 2316.xx)

Main boom angle 75°

Main boom 44 m

Radius	Jib length in (m)							
	41	53	65	77	89	95	101	113
(m)	t	t	t	t	t	t	t	t
31.9	26.3							
36	22.6							
38	21.0	20.0						
40	19.7	18.7						
44	17.3	16.4	15.3					
46	16.3	15.4	14.4					
48	15.4	14.5	13.5	12.4				
50	14.5	13.6	12.6	11.6				
55		11.8	10.9	9.9	8.9	8.4		
60		10.3	9.4	8.4	7.5	7.0	6.5	
65		9.0	8.2	7.2	6.3	5.8	5.3	4.3
70			7.1	6.2	5.2	4.8	4.3	3.3
75			6.1	5.3	4.3	3.9	3.4	2.4
80				4.5	3.6	3.1	2.6	
85				3.8	2.9	2.4		
90					2.3			

Main boom 50 m

Radius	Jib length in (m)							
	41	53	65	77	89	95	101	113
(m)	t	t	t	t	t	t	t	t
33.5	23.7							
36	21.6							
38	20.1							
40	18.8	17.7						
42	17.6	16.6						
44	16.5	15.5	14.5					
46	15.6	14.6	13.5					
48	14.7	13.7	12.7					
50	13.8	12.9	11.9	10.8				
55	12.0	11.2	10.2	9.2	8.1			
60		9.7	8.8	7.8	6.8	6.3	5.7	
65		8.5	7.6	6.6	5.6	5.2	4.6	3.6
70			6.6	5.6	4.7	4.2	3.7	2.7
75			5.7	4.8	3.8	3.3	2.8	
80				4.0	3.1	2.6	2.1	
85				3.3	2.4			

Main boom 62 m

Radius	Jib length in (m)						
	41	53	65	77	89	95	101
(m)	t	t	t	t	t	t	t
36.6	19.0						
38	18.0						
40	16.8						
42	15.7	14.6					
44	14.8	13.7					
46	13.9	12.8					
48	13.1	12.0	10.9				
50	12.3	11.3	10.2				
55	10.7	9.7	8.7	7.6			
60		8.4	7.4	6.3	5.3	4.8	
65		7.3	6.3	5.3	4.3	3.8	3.2
70		6.3	5.4	4.4	3.4	2.9	2.4
75			4.6	3.6	2.6	2.2	
80			3.9	2.9			
85				2.3			

Main boom 74 m

Radius	Jib length in (m)					
	41	53	65	77	89	95
(m)	t	t	t	t	t	t
39.7	14.7					
40	14.6					
42	13.6					
44	12.7					
46	11.9	10.8				
48	11.2	10.1				
50	10.5	9.4	8.3			
55	9.1	8.0	6.9	5.8		
60	7.8	6.9	5.8	4.7	3.6	
65		5.9	4.9	3.8	2.7	2.2
70		5.0	4.1	3.0		
75			3.4	2.3		
80			2.7			

Main boom 80 m

Radius	Jib length in (m)			
	41	53	65	77
(m)	t	t	t	t
41.2	12.8			
42	12.4			
44	11.6			
46	10.9			
48	10.2	9.0		
50	9.6	8.4		
55	8.2	7.2	6.0	
60	7.1	6.1	5.0	3.9
65		5.2	4.1	3.0
70		4.4	3.3	2.3
75			2.7	
80			2.1	

Main boom 86 m

Radius	Jib length in (m)			
	41	53	65	77
(m)	t	t	t	t
42.8	10.9			
44	10.4			
46	9.7			
48	9.1	7.9		
50	8.5	7.4		
55	7.3	6.2	5.0	
60	6.2	5.2	4.1	2.9
65		4.3	3.3	2.1
70		3.6	2.6	
75		2.9		

Capacities in metric tons with luffing jib (No. 2316.xx), 124 t counterweight + 57 t carbody counterweight. Above lift chart is for reference only. For actual lift duty and complete chart with all available configurations please refer to lift chart in operator's cab or manual.

Lift chart - luffing jib (No. 2316.xx)

Main boom angle 75°

max. 120 t suspended counterweight at 13 m radius

Main boom 44 m

Radius	Jib length in (m)							
	41	53	65	77	89	95	101	113
(m)	t	t	t	t	t	t	t	t
32	52.2							
38	45.3	38.5						
44	36.5	34.6	26.9					
48	30.8	30.4	26.2	18.8				
50	28.9	28.5	25.7	18.8				
55		25.1	22.6	18.1	13.3	10.9		
60		21.6	20.2	17.2	12.8	10.7	9.1	
65		17.7	18.0	16.1	12.3	10.3	8.9	6.0
70			15.9	14.6	11.8	10.0	8.6	5.8
75			13.6	13.0	11.2	9.5	8.3	5.6
80				11.4	10.3	9.0	8.0	5.3
85				9.8	9.3	8.4	7.5	5.0
90					8.2	7.7	7.0	4.4
95					7.0	6.8	6.3	3.3
105						4.3	4.6	
110							3.3	

Main boom 50 m

Radius	Jib length in (m)							
	41	53	65	77	89	95	101	113
(m)	t	t	t	t	t	t	t	t
33.5	50.4							
40	44.0	37.0						
44	38.2	35.3	26.1					
50	29.7	29.7	25.3	18.2				
55	24.4	26.0	23.1	17.8	12.9			
60		22.2	20.6	17.1	12.6	10.5	8.9	
65		19.0	18.6	16.1	12.2	10.2	8.7	5.8
70			16.3	14.9	11.7	9.8	8.4	5.7
75			14.4	13.4	11.2	9.4	8.2	5.5
80				11.8	10.3	9.0	7.9	5.2
85				10.4	9.5	8.4	7.5	4.9
90					8.5	7.8	7.0	4.6
95					7.4	7.1	6.5	3.5
100					6.0	6.1	5.9	2.3
105						4.9	5.0	
110							3.8	

Main boom 62 m

Radius	Jib length in (m)							
	41	53	65	77	89	95	101	113
(m)	t	t	t	t	t	t	t	t
36.6	45.3							
42	42.3	33.5						
48	34.0	32.4	23.7					
55	25.8	27.0	22.6	16.7				
60		23.0	20.7	16.3	11.9	9.9		
65		19.4	18.7	15.7	11.6	9.7	8.3	
70		16.2	16.5	15.1	11.2	9.4	8.1	5.3
75			14.4	13.8	10.7	9.1	7.8	5.2
80			12.3	12.4	10.2	8.7	7.6	5.0
85				11.0	9.6	8.3	7.3	4.7
90				9.4	8.8	7.8	6.9	4.4
95					8.0	7.3	6.5	3.9
100					6.8	6.6	6.0	2.9
105						5.5	5.3	
110						4.1	4.4	
115							3.2	

Main boom 74 m

Radius	Jib length in (m)							
	41	53	65	77	89	95	101	113
(m)	t	t	t	t	t	t	t	t
39.7	36.3							
46	33.1	28.3						
50	30.1	27.1	21.0					
55	25.2	24.9	20.5	15.1				
60	21.7	22.2	19.7	14.9	10.8			
65		18.7	18.7	14.4	10.6	9.0	7.6	
70		16.4	16.3	13.9	10.3	8.8	7.5	
75			13.6	13.2	9.9	8.5	7.3	4.8
80			12.0	11.7	9.5	8.1	7.0	4.6
85				10.0	8.9	7.8	6.7	4.3
90				8.9	8.0	7.2	6.4	4.0
95				7.5	7.0	6.5	5.8	3.7
100					6.2	5.8	5.2	3.1
105					5.1	5.0	4.5	2.2
110						4.1	3.8	
115							3.1	

Main boom 80 m

Radius	Jib length in (m)							
	41	53	65	77	89	95	101	113
(m)	t	t	t	t	t	t	t	t
42	31.1							
48	28.3	24.6						
50	27.3	24.0						
55	24.0	22.4	18.6					
60	20.8	20.7	17.5	14.0				
65		18.0	16.5	13.6	10.0	8.4		
70		15.7	15.0	13.0	9.7	8.3	7.0	
75			13.0	12.4	9.4	8.0	6.9	4.4
80			11.4	11.1	9.0	7.7	6.6	4.2
85			9.9	9.5	8.4	7.4	6.3	4.0
90				8.3	7.5	6.8	6.1	3.7
95				7.2	6.5	6.0	5.5	3.5
100					5.6	5.2	4.8	3.1
105					4.8	4.4	4.0	2.3
110						3.7	3.3	
115						2.7	2.7	

Main boom 86 m

Radius	Jib length in (m)							
	41	53	65	77	89	95	101	113
(m)	t	t	t	t	t	t	t	t
42.8	26.6							
48	24.9	20.7						
50	24.1	20.4						
55	22.0	18.9	16.2					
60	19.8	17.4	15.2	12.4				
65		15.8	14.2	11.9	9.1			
70		14.1	13.2	11.3	8.9	7.6	6.4	
75		12.5	11.9	10.6	8.5	7.4	6.3	3.9
80			10.6	9.7	7.9	6.9	6.0	3.8
85			9.5	8.6	7.3	6.5	5.6	3.6
90				7.6	6.6	5.9	5.1	3.3
95				6.7	5.7	5.2	4.6	3.0
100					4.9	4.5	4.0	2.7
105					4.3	3.8	3.4	2.1
110					3.4	3.2	2.7	
115						2.5	2.2	

Suspended counterweight **120 t** **90 t** **75 t** **50 t** **0 t**

Capacities in metric tons with luffing jib (No. 2316.xx), 124 t counterweight + 57 t carbody counterweight. Above lift chart is for reference only. For actual lift duty and complete chart with all available configurations please refer to lift chart in operator's cab or manual.

Lift chart – luffing jib (No. 2316.xx)

Main boom angle 65°

max. 120 t suspended counterweight at 13 m radius

Main boom 44 m

Radius	Jib length in (m)							
	41	53	65	77	89	95	101	113
(m)	t	t	t	t	t	t	t	t
46	43.9							
48	42.2							
50	39.2							
55	33.1	31.0						
60	28.2	26.8	23.1					
65		23.5	21.3					
70		20.9	19.2	16.4				
75			17.2	15.3	11.3			
80			15.5	14.0	11.1	9.2	7.7	
85				12.4	10.7	9.0	7.7	
90				11.3	9.9	8.7	7.5	4.7
95				9.9	9.0	8.2	7.3	4.5
100					8.3	7.6	6.8	4.3
105					7.3	6.9	6.3	3.2
110						6.2	5.7	
115							4.9	

Main boom 50 m

Radius	Jib length in (m)							
	41	53	65	77	89	95	101	113
(m)	t	t	t	t	t	t	t	t
48	43.4							
50	42.6							
55	35.9	31.6						
60	30.6	28.8						
65		25.3	22.4					
70		22.1	20.0	15.9				
75		19.3	18.2	15.6				
80			16.3	14.6	10.9	8.9		
85			14.6	13.2	10.7	8.8	7.4	
90				11.8	10.2	8.7	7.4	4.5
95				10.7	9.5	8.3	7.3	4.4
100					8.6	7.8	6.9	4.2
105					7.9	7.3	6.5	3.7
110						6.6	6.0	2.4
115						5.7	5.4	
120							4.5	

Main boom 62 m

Radius	Jib length in (m)							
	41	53	65	77	89	95	101	113
(m)	t	t	t	t	t	t	t	t
55	36.0							
60	32.5	30.5						
65	29.5	28.5						
70		24.8	21.2					
75		21.7	19.4	14.8				
80		19.0	17.6	14.7				
85			15.7	14.3	10.1	8.3		
90			14.1	13.0	10.0	8.3	6.9	
95				11.7	9.7	8.2	6.9	4.0
100				10.7	9.2	8.0	6.8	4.0
105					8.6	7.6	6.6	3.9
110					7.9	7.2	6.3	3.5
115						6.6	5.9	2.3
120						5.7	5.3	
125							4.5	

Main boom 74 m

Radius	Jib length in (m)							
	41	53	65	77	89	95	101	113
(m)	t	t	t	t	t	t	t	t
60	30.1							
65	27.4	26.2						
70	25.0	23.9						
75		21.9	19.1					
80		20.1	18.8	13.4				
85		18.4	17.2	13.4				
90			15.5	13.2	9.2	7.6		
95			14.0	12.4	9.1	7.6	6.3	
100				11.5	9.0	7.5	6.3	3.5
105				10.6	8.7	7.4	6.2	3.5
110					8.3	7.3	6.1	3.4
115					7.7	7.0	5.9	3.2
120						6.4	5.7	2.1
125						5.6	5.1	
130							4.4	

Main boom 80 m

Radius	Jib length in (m)							
	41	53	65	77	89	95	101	113
(m)	t	t	t	t	t	t	t	t
60.5	28.6							
65	26.2							
70	23.9	22.7						
75	21.5	20.8	17.8					
80		19.1	17.7					
85		17.6	16.5	12.6				
90			15.2	12.6	8.6			
95			14.0	12.2	8.6	7.1	5.9	
100				11.7	8.6	7.1	5.9	
105				10.9	8.4	7.1	5.9	3.2
110				9.8	8.2	7.0	5.8	3.2
115					7.8	6.8	5.7	3.1
120					7.1	6.5	5.6	2.5
125						5.9	5.2	
130							4.7	

Main boom 86 m

Radius	Jib length in (m)							
	41	53	65	77	89	95	101	113
(m)	t	t	t	t	t	t	t	t
65	24.9							
70	22.7	19.4						
75	20.8	19.0						
80		18.0	15.0					
85		16.5	14.7	11.3				
90		15.2	14.2	11.2				
95			13.1	11.1	7.9	6.6		
100			12.0	10.8	7.9	6.6	5.4	
105				10.1	7.8	6.5	5.4	2.9
110				9.3	7.6	6.4	5.3	2.9
115					7.4	6.3	5.2	2.8
120					6.8	6.1	5.1	2.7
125						5.7	5.0	
130						5.2	4.6	
135							4.0	

Suspended counterweight **120 t** **90 t** **75 t** **50 t** **0 t**

Capacities in metric tons with luffing jib (No. 2316.xx), 124 t counterweight + 57 t carbody counterweight. Above lift chart is for reference only. For actual lift duty and complete chart with all available configurations please refer to lift chart in operator's cab or manual.

Lift chart - luffing jib (No. 2316.xx)

Main boom angle 45°

max. 120 t suspended counterweight at 13 m radius

Main boom 44 m

Radius	Jib length in (m)							
	41	53	65	77	89	95	101	113
(m)	t	t	t	t	t	t	t	t
67.6	27.3							
70	26.2							
80		21.1						
85		19.4						
90			16.3					
95			14.8					
100				11.9				
105				10.7				
110					8.5			
115					7.8	7.2		
120						6.6	5.8	
125						5.9	5.2	
130							4.6	2.0

Main boom 50 m

Radius	Jib length in (m)							
	41	53	65	77	89	95	101	
(m)	t	t	t	t	t	t	t	
71.9	23.9							
75	22.7							
85		18.2						
95			14.6					
100			13.5					
105				11.5				
110				10.6				
115					8.3			
120					7.7	7.0		
125						6.5	5.6	
130							5.1	
135							4.5	
140								

Main boom 62 m

Radius	Jib length in (m)						
	41	53	65	77	89	95	101
(m)	t	t	t	t	t	t	t
80.3	18.1						
85	16.7						
95		13.3					
100			11.2				
105			10.3				
110				8.4			
115				7.7			
120				7.1	6.0		
125					5.4	4.9	
130					4.9	4.4	3.8
135						3.9	3.3
140							2.8

Main boom 74 m

Radius	Jib length in (m)					
	41	53	65	77	89	
(m)	t	t	t	t	t	
88.8	13.0					
90	12.8					
100		9.8				
105		9.0				
110			7.1			
115			6.5			
120				4.8		
125				4.3		
130					2.7	
135					2.3	
140						
145						

Main boom 80 m

Radius	Jib length in (m)			
	41	53	65	77
(m)	t	t	t	t
93.1	10.8			
95	10.4			
105		7.7		
110		7.1		
115			5.3	
120			4.8	
125				3.2
130				2.8
135				
140				
145				

Main boom 86 m

Radius	Jib length in (m)		
	41	53	65
(m)	t	t	t
97.3	8.6		
100	8.2		
110		5.8	
120			3.6
125			3.1
130			
135			

Suspended counterweight 120 t 90 t 75 t 50 t 0 t

Capacities in metric tons with luffing jib (No. 2316.xx), 124 t counterweight + 57 t carbody counterweight. Above lift chart is for reference only. For actual lift duty and complete chart with all available configurations please refer to lift chart in operator's cab or manual.

Lift chart - luffing jib (No. 2316.xx)

Main boom angle 75°

120 t wheeled counterweight carriage at 15.8 m radius

Main boom 44 m

Radius	Jib length in (m)							
	41	53	65	77	89	95	101	113
(m)	t	t	t	t	t	t	t	t
32	52.2							
38	45.3	38.5						
44	36.5	34.6	26.9					
48	30.8	30.4	26.2	18.8				
50	28.9	28.5	25.7	18.8				
55		25.1	22.6	18.1	13.3	10.9		
60		21.6	20.2	17.2	12.8	10.7	9.1	
65		17.7	18.0	16.1	12.3	10.3	8.9	6.0
70			15.9	14.6	11.8	10.0	8.6	5.8
75			13.6	13.0	11.2	9.5	8.3	5.6
80				11.4	10.3	9.0	8.0	5.3
85				9.8	9.3	8.4	7.5	5.0
90					8.2	7.7	7.0	4.4
95					7.0	6.8	6.3	3.3
105						4.3	4.6	
110							3.3	

Main boom 50 m

Radius	Jib length in (m)							
	41	53	65	77	89	95	101	113
(m)	t	t	t	t	t	t	t	t
33.5	50.4							
40	44.0	37.0						
44	38.2	35.3	26.1					
50	29.7	29.7	25.3	18.2				
55	24.4	26.0	23.1	17.8	12.9			
60		22.2	20.6	17.1	12.6	10.5	8.9	
65		19.0	18.6	16.1	12.2	10.2	8.7	5.8
70			16.3	14.9	11.7	9.8	8.4	5.7
75			14.4	13.4	11.2	9.4	8.2	5.5
80				11.8	10.3	9.0	7.9	5.2
85				10.4	9.5	8.4	7.5	4.9
90					8.5	7.8	7.0	4.6
95					7.4	7.1	6.5	3.5
100					6.0	6.1	5.9	2.3
105						4.9	5.0	
110							3.8	

Main boom 62 m

Radius	Jib length in (m)							
	41	53	65	77	89	95	101	113
(m)	t	t	t	t	t	t	t	t
36.6	45.3							
42	42.3	33.5						
48	34.0	32.4	23.7					
55	25.8	27.0	22.6	16.7				
60		23.0	20.7	16.3	11.9	9.9		
65		19.4	18.7	15.7	11.6	9.7	8.3	
70		16.2	16.5	15.1	11.2	9.4	8.1	5.3
75			14.4	13.8	10.7	9.1	7.8	5.2
80			12.3	12.4	10.2	8.7	7.6	5.0
85				11.0	9.6	8.3	7.3	4.7
90				9.4	8.8	7.8	6.9	4.4
95					8.0	7.3	6.5	3.9
100					6.8	6.6	6.0	2.9
105						5.5	5.3	
110						4.1	4.4	
115							3.2	

Main boom 74 m

Radius	Jib length in (m)							
	41	53	65	77	89	95	101	113
(m)	t	t	t	t	t	t	t	t
39.7	36.3							
46	33.1	28.3						
50	30.1	27.1	21.0					
55	25.2	24.9	20.5	15.1				
60	21.7	22.2	19.7	14.9	10.8			
65		18.7	18.7	14.4	10.6	9.0	7.6	
70		16.4	16.3	13.9	10.3	8.8	7.5	
75			13.6	13.2	9.9	8.5	7.3	4.8
80			12.0	11.7	9.5	8.1	7.0	4.6
85				10.0	8.9	7.8	6.7	4.3
90				8.9	8.0	7.2	6.4	4.0
95				7.5	7.0	6.5	5.8	3.7
100					6.2	5.8	5.2	3.1
105					5.1	5.0	4.5	2.2
110						4.1	3.8	
115							3.1	

Main boom 80 m

Radius	Jib length in (m)							
	41	53	65	77	89	95	101	113
(m)	t	t	t	t	t	t	t	t
41.2	30.0							
48	28.3	24.6						
50	27.3	24.0						
55	24.0	22.4	18.6					
60	20.8	20.7	17.5	14.0				
65		18.0	16.5	13.6	10.0	8.4		
70		15.7	15.0	13.0	9.7	8.3	7.0	
75			13.0	12.4	9.4	8.0	6.9	4.4
80			11.4	11.1	9.0	7.7	6.6	4.2
85			9.9	9.5	8.4	7.4	6.3	4.0
90				8.3	7.5	6.8	6.1	3.7
95				7.2	6.5	6.0	5.5	3.5
100					5.6	5.2	4.8	3.1
105					4.8	4.4	4.0	2.3
110						3.7	3.3	
115						2.7	2.7	

Main boom 86 m

Radius	Jib length in (m)							
	41	53	65	77	89	95	101	113
(m)	t	t	t	t	t	t	t	t
42.8	26.6							
48	24.9	20.7						
50	24.1	20.4						
55	22.0	18.9	16.2					
60	19.8	17.4	15.2	12.4				
65		15.8	14.2	11.9	9.1			
70		14.1	13.2	11.3	8.9	7.6	6.4	
75		12.5	11.9	10.6	8.5	7.4	6.3	3.9
80			10.6	9.7	7.9	6.9	6.0	3.8
85			9.5	8.6	7.3	6.5	5.6	3.6
90				7.6	6.6	5.9	5.1	3.3
95				6.7	5.7	5.2	4.6	3.0
100					4.9	4.5	4.0	2.7
105					4.3	3.8	3.4	2.1
110					3.4	3.2	2.7	
115						2.5	2.2	

Capacities in metric tons with luffing jib (No. 2316.xx), 124 t counterweight + 57 t carbody counterweight. Above lift chart is for reference only. For actual lift duty and complete chart with all available configurations please refer to lift chart in operator's cab or manual.

Lift chart – luffing jib (No. 2316.xx)

Main boom angle 65°

120 t wheeled counterweight carriage at 15.8 m radius

Main boom 44 m

Radius	Jib length in (m)							
	41	53	65	77	89	95	101	113
(m)	t	t	t	t	t	t	t	t
46	43.9							
48	42.2							
50	39.2							
55	33.1	31.0						
60	28.2	26.8	23.1					
65		23.5	21.3					
70		20.9	19.2	16.4				
75			17.2	15.3	11.3			
80			15.5	14.0	11.1	9.2	7.7	
85				12.4	10.7	9.0	7.7	
90				11.3	9.9	8.7	7.5	4.7
95				9.9	9.0	8.2	7.3	4.5
100					8.3	7.6	6.8	4.3
105					7.3	6.9	6.3	3.2
110						6.2	5.7	
115							4.9	

Main boom 50 m

Radius	Jib length in (m)							
	41	53	65	77	89	95	101	113
(m)	t	t	t	t	t	t	t	t
48	43.4							
50	42.6							
55	35.9	31.6						
60	30.6	28.8						
65		25.3	22.4					
70		22.1	20.0	15.9				
75		19.3	18.2	15.6				
80			16.3	14.6	10.9	8.9		
85			14.6	13.2	10.7	8.8	7.4	
90				11.8	10.2	8.7	7.4	4.5
95				10.7	9.5	8.3	7.3	4.4
100					8.6	7.8	6.9	4.2
105					7.9	7.3	6.5	3.7
110						6.6	6.0	2.4
115						5.7	5.4	
120							4.5	

Main boom 62 m

Radius	Jib length in (m)							
	41	53	65	77	89	95	101	113
(m)	t	t	t	t	t	t	t	t
55	41.0							
60	35.4	30.5						
65	30.2	28.5						
70		24.8	21.2					
75		21.7	19.4	14.8				
80		19.0	17.6	14.7				
85			15.7	14.3	10.1	8.3		
90			14.1	13.0	10.0	8.3	6.9	
95				11.7	9.7	8.2	6.9	4.0
100				10.7	9.2	8.0	6.8	4.0
105					8.6	7.6	6.6	3.9
110					7.9	7.2	6.3	3.5
115						6.6	5.9	2.3
120						5.7	5.3	
125							4.5	

Main boom 74 m

Radius	Jib length in (m)							
	41	53	65	77	89	95	101	113
(m)	t	t	t	t	t	t	t	t
60	34.6							
65	31.4	27.3						
70	28.7	26.7						
75		24.4	19.1					
80		21.4	18.8	13.4				
85		18.9	17.2	13.4				
90			15.5	13.2	9.2	7.6		
95			14.0	12.4	9.1	7.6	6.3	
100				11.5	9.0	7.5	6.3	3.5
105				10.6	8.7	7.4	6.2	3.5
110					8.3	7.3	6.1	3.4
115					7.7	7.0	5.9	3.2
120						6.4	5.7	2.1
125						5.6	5.1	
130							4.4	

Main boom 80 m

Radius	Jib length in (m)							
	41	53	65	77	89	95	101	113
(m)	t	t	t	t	t	t	t	t
65	30.1							
70	27.8	23.9						
75	25.4	23.5	17.8					
80		22.0	17.7					
85		20.1	17.1	12.6				
90			15.9	12.6	8.6			
95			14.6	12.2	8.6	7.1	5.9	
100				11.7	8.6	7.1	5.9	
105				10.9	8.4	7.1	5.9	3.2
110				9.8	8.2	7.0	5.8	3.2
115					7.8	6.8	5.7	3.1
120					7.1	6.5	5.6	2.5
125						5.9	5.2	
130							4.7	

Main boom 86 m

Radius	Jib length in (m)							
	41	53	65	77	89	95	101	113
(m)	t	t	t	t	t	t	t	t
63	25.0							
65	25.3							
70	24.1	19.4						
75	22.8	19.0						
80		18.1	15.0					
85		17.2	14.7	11.3				
90		16.2	14.2	11.2				
95			13.6	11.1	7.9	6.6		
100			12.9	10.8	7.9	6.6	5.4	
105				10.5	7.8	6.5	5.4	2.9
110				9.8	7.6	6.4	5.3	2.9
115					7.4	6.3	5.2	2.8
120					7.0	6.1	5.1	2.7
125						5.8	5.0	
130						5.2	4.6	
135							4.0	

Capacities in metric tons with luffing jib (No. 2316.xx), 124 t counterweight + 57 t carbody counterweight. Above lift chart is for reference only. For actual lift duty and complete chart with all available configurations please refer to lift chart in operator's cab or manual.

Lift chart - luffing jib (No. 2316.xx)

Main boom angle 45°

120 t wheeled counterweight carriage at 15.8 m radius

Main boom 44 m

Radius (m)	Jib length in (m)							
	41	53	65	77	89	95	101	113
67.6	t	t	t	t	t	t	t	t
70	30.1							
80	29.9							
85		22.2						
85		19.8						
90			16.3					
95			14.8					
100				11.9				
105				10.7				
110					8.5			
115					7.8	7.2		
120						6.6	5.8	
125						5.9	5.2	
130							4.6	2.0

Main boom 50 m

Radius (m)	Jib length in (m)							
	41	53	65	77	89	95	101	
71.9	t	t	t	t	t	t	t	
75	27.7							
75	26.3							
85		21.4						
95			16.0					
100			14.6					
105				11.6				
110				10.6				
115					8.3			
120					7.7	7.0		
125						6.5	5.6	
130							5.1	
135							4.5	

Main boom 62 m

Radius (m)	Jib length in (m)						
	41	53	65	77	89	95	101
80.3	t	t	t	t	t	t	t
85	21.4						
85	19.9						
95		16.1					
100			13.8				
105			12.8				
110				10.8			
115				10.0			
120				9.3	7.9		
125					7.5	6.4	
130					6.9	6.4	5.2
135						5.8	5.2
140							4.8

Main boom 74 m

Radius (m)	Jib length in (m)						
	41	53	65	77	89	95	101
88.8	t	t	t	t	t	t	t
88.8	16.0						
90	15.8						
100		12.4					
105		11.5					
110			9.6				
115			8.8				
120				7.1			
125				6.5			
130					4.8		
135					4.3	3.8	
140					3.8	3.3	2.7
145						2.9	2.2

Main boom 80 m

Radius (m)	Jib length in (m)					
	41	53	65	77	89	95
93.1	t	t	t	t	t	t
95	13.7					
95	13.3					
105		10.3				
110		9.5				
115			7.7			
120			7.0			
125				5.3		
130				4.8		
135					3.2	
140					2.8	2.3
145					2.3	

Main boom 86 m

Radius (m)	Jib length in (m)			
	41	53	65	77
97.3	t	t	t	t
97.3	11.4			
100	10.9			
110		8.2		
120			5.8	
125			5.3	
130				3.6
135				3.2

Capacities in metric tons with luffing jib (No. 2316.xx), 124 t counterweight + 57 t carbody counterweight. Above lift chart is for reference only. For actual lift duty and complete chart with all available configurations please refer to lift chart in operator's cab or manual.

Drive options

Wheeled counterweight carriage

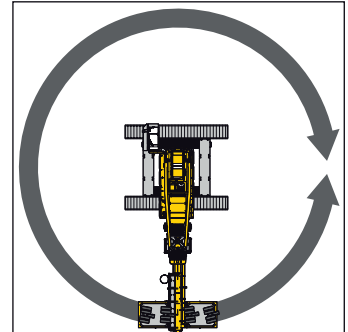
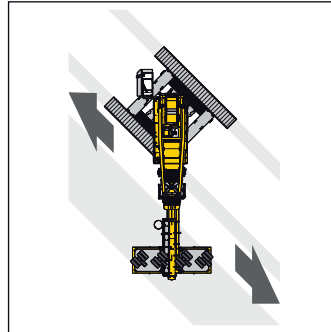
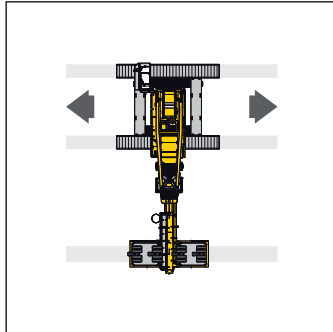
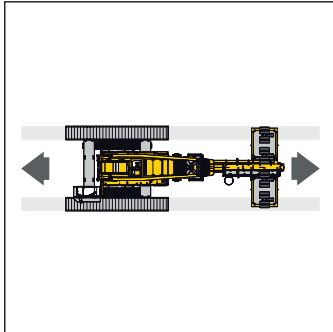

Carriage with steerable axles

Carriage with blocked steering axle

