

Technical data Hydraulic lift crane

LR 1300
Litronic®

Complies with ANSI/ASME B 30.5

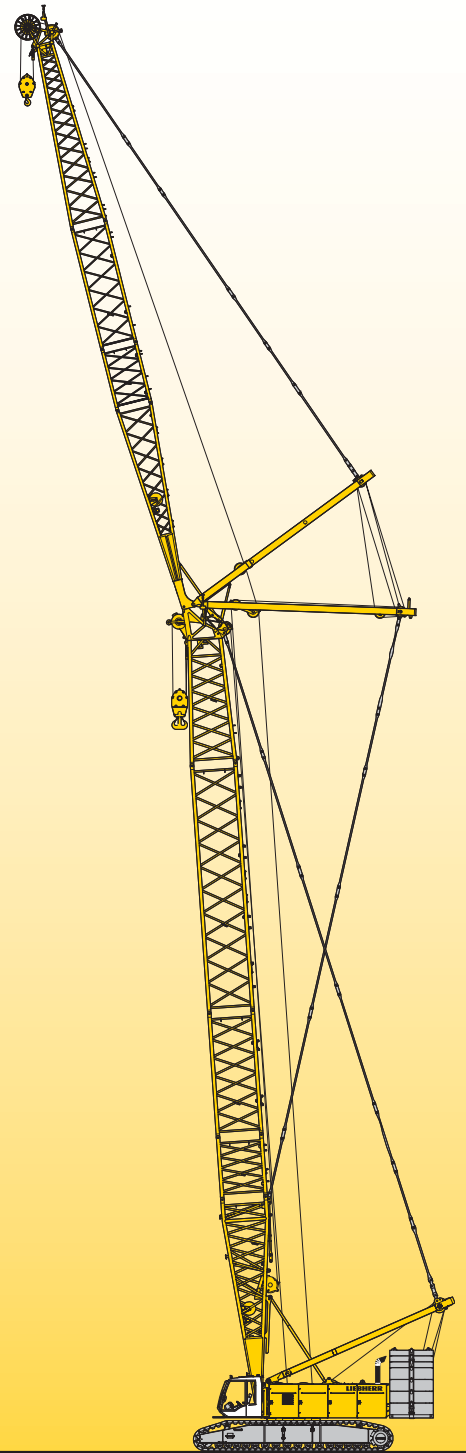

LIEBHERR

Dimensions

Basic machine with undercarriage

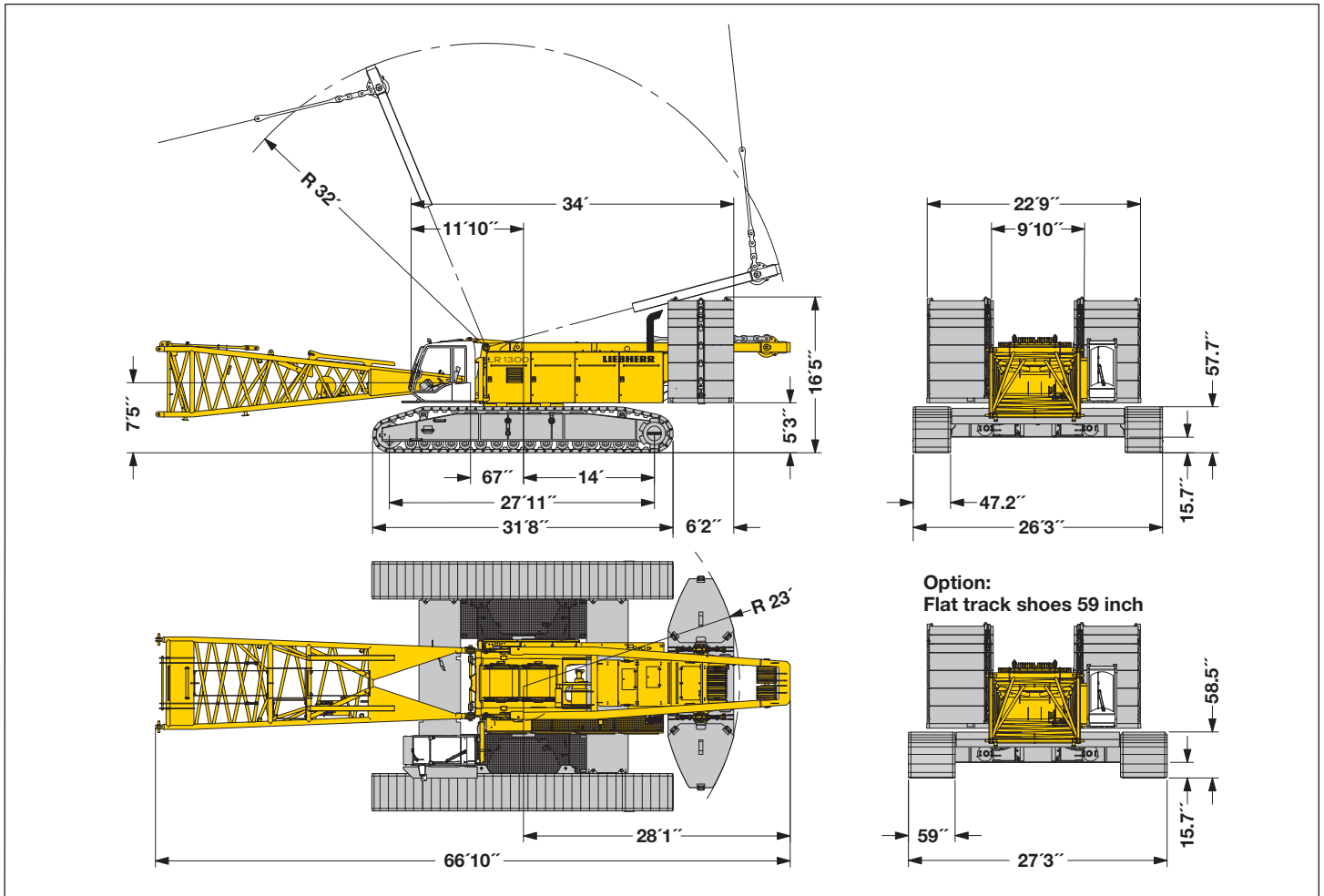

Operating weight

The operating weight includes the basic machine with crawlers, 2 main winches 33,720 lbf and 66 ft main boom, consisting of A-frame, boom foot (33 ft), boom head (23 ft), boom extension (10 ft), 273,400 lbs basic counterweight, 125,700 lbs carbody counterweight and 661,400 lbs hook block.

Total weight _____ approx. 639,350 lbs

Ground pressure

Ground bearing pressure _____ 20.6 PSI

Equipment

Main boom (No. 2821.xx) max. length _____ 322 ft
 High reach boom (No. 2821.xx and 2316.xx) _____ 404 ft
 Luffing jib (No. 2316.xx) max. length _____ 371 ft
 Max. combination _____ main boom 194 ft and luffing jib 371 ft
 Auxiliary jib _____ 79,400 lbs

Remarks

1. The lifting capacities stated are valid for lifting operation only (corresponding with crane classification according to F.E.M. 1.001 crane group A1).
2. Crane standing on firm, horizontal ground.
3. The weight of the lifting device (hoisting ropes, hook block, shackle etc.) must be deducted from the gross lifting capacity to obtain a net lifting value.
4. Additional equipment on boom (e.g. boom walkways, auxiliary jib) must be deducted to get the net lifting capacity.
5. For max. wind speed please refer to lift chart in operator's cab or manual.
6. Working radii are measured from center of swing and under load.
7. The lifting capacities are valid for 360 degrees of swing.
8. Calculation of stability under load is based on ANSI/ASME B 30.5 load ratings as well as ISO 4305 Table 2 and is tested according to SAE J765.
9. Loads for calculation of structures are corresponding to F.E.M. 1.001-1998 and are tested according to SAE J987.

Transport dimensions and weights

Basic machine and boom (No. 2821.xx)

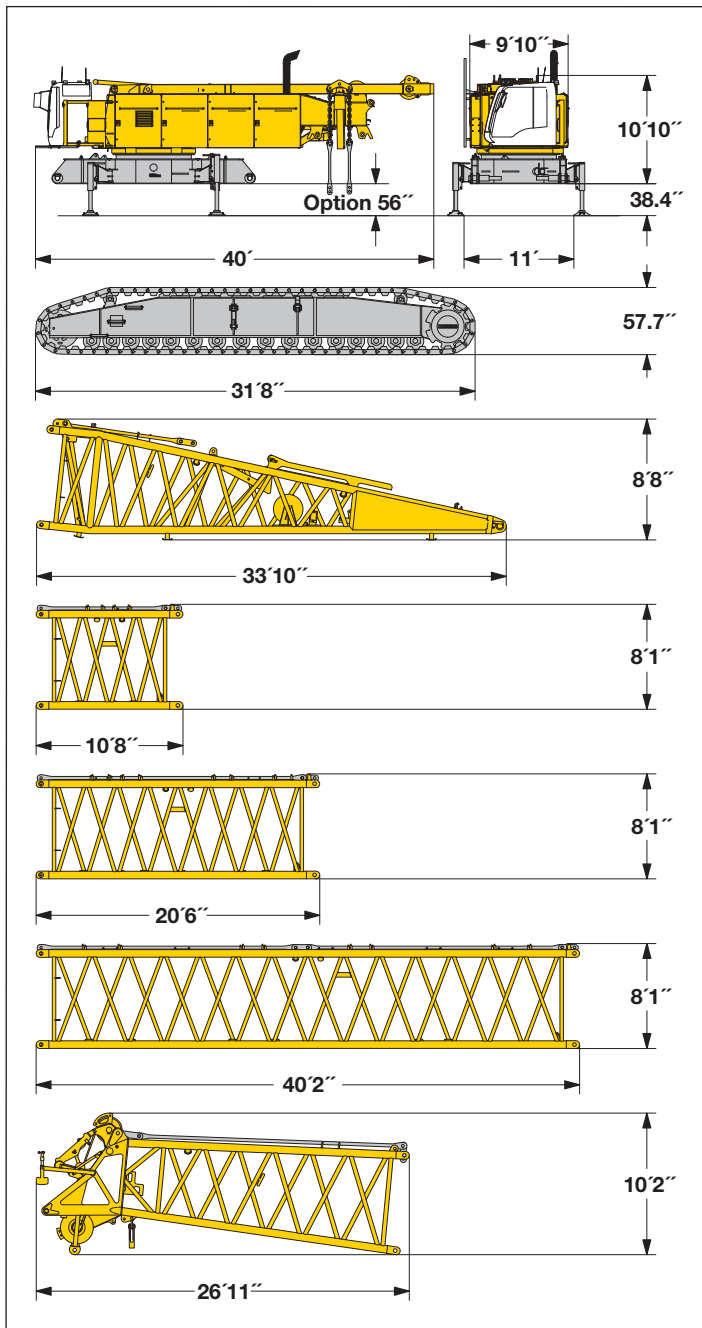

1) Pendant straps for main boom • 2) Pendant straps for jib

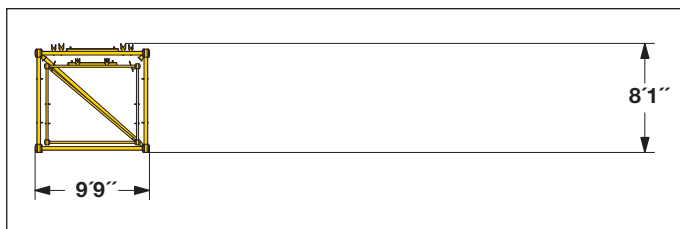

*) Including pendants

Basic machine

with A-frame, 2x 48,350 lbf crane winches, without boom foot, hoisting ropes, basic counterweight and crawlers

Width	9'10"
Weight excluding hoist ropes	99,210 lbs
Weight including hoist ropes (2x 2,182 ft)	103,620 lbs

Crawler

2 x

	Optional	Standard
Track pads	59 inch	47.2 inch
Width	59 inch	55.1 inch
Weight	57,800 lbs	49,300 lbs

Boom foot (No. 2821.30)

Width	9'9"
Weight incl. winch and rope	16,320 lbs
Weight without winch	12,600 lbs

Boom section (No. 2821.24)

10 ft

Width	9'9"
Weight with HPT ¹⁾	2,530 lbs
Weight with HPT ¹⁾ and NDL ²⁾	2,740 lbs

Boom section (No. 2821.24)

20 ft

Width	9'9"
Weight with HPT ¹⁾	3,840 lbs
Weight with HPT ¹⁾ and NDL ²⁾	4,240 lbs

Boom section (No. 2821.24)

40 ft

Width	9'9"
Weight with HPT ¹⁾	6,620 lbs
Weight with HPT ¹⁾ and NDL ²⁾	7,420 lbs

Boom head (No. 2821.24)

Width	9'9"
Weight with HPT ¹⁾	11,900 lbs

Boom - luffing jib transport option

No. 2821.xx/2316.xx	40/40	20/20	30/30 ft
Length	41'	20'6"	10'8"
Weight*	11,390	6,340	4,090 lbs

Transport dimensions and weights

Luffing jib (No. 2316.xx)

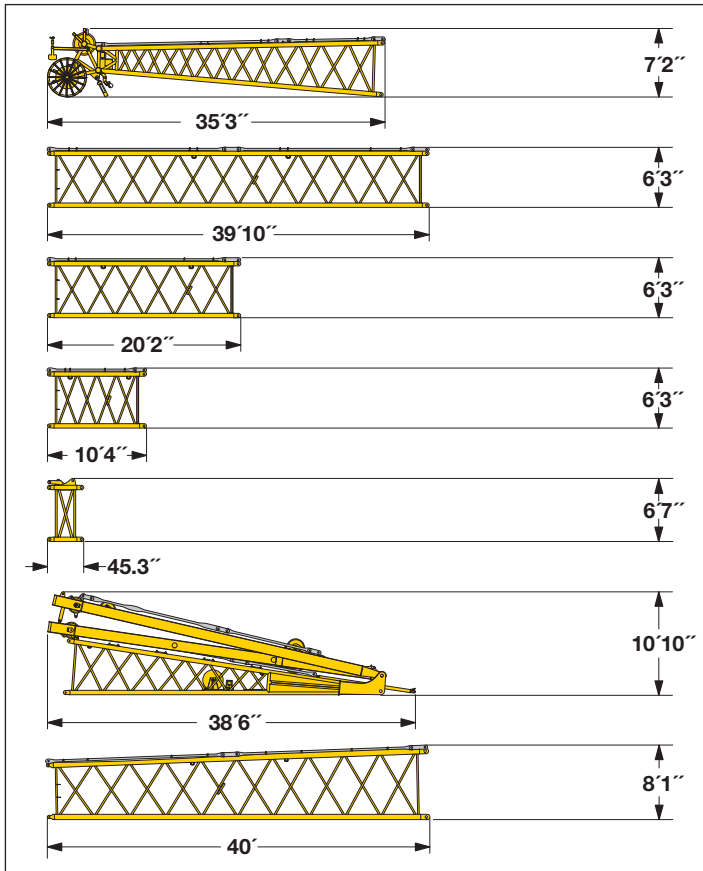

Luffing jib head (No. 2316.20)

Width	8'
Weight*	5,070 lbs

Luffing jib section (No. 2316.20) **40 ft**

Width	8'
Weight*	3,970 lbs

Luffing jib section (No. 2316.20) **20 ft**

Width	8'
Weight*	2,100 lbs

Luffing jib section (No. 2316.20) **10 ft**

Width	8'
Weight*	1,350 lbs

L-boom jib section (No. 2316.20) **39.4 inch**

Width	8'
Weight*	1,410 lbs

Luffing jib foot with A-frames (No. 2316.22)

Width	8'9"
Weight*	17,450 lbs

L-boom sect. tapered (No. 2821/2316.24) **40 ft**

Width	9'9"
Weight*	5,950 lbs

Fixed jib (No. 1713.xx)

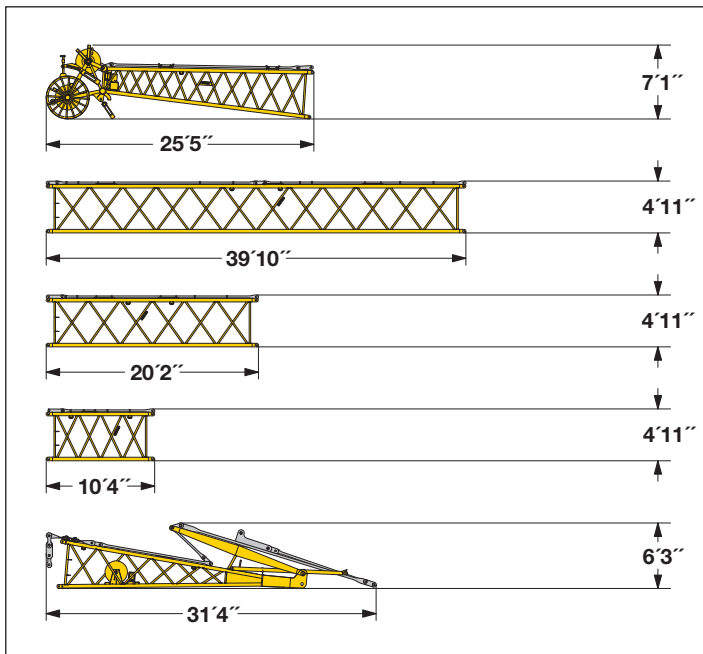

Jib head (No. 1713.21)

Width	6'
Weight*	3,030 lbs

Jib section (No. 1713.18) **40 ft**

Width	6'
Weight*	2,520 lbs

Jib section (No. 1713.18) **20 ft**

Width	6'
Weight*	1,400 lbs

Jib section (No. 1713.18) **10 ft**

Width	6'
Weight*	930 lbs

Jib foot with A-frame (No. 1713.22)

Width	8'
Weight*	5,070 lbs

*) Including pendants

Transport dimensions and weights

Luffing jib (No. 1916.xx)

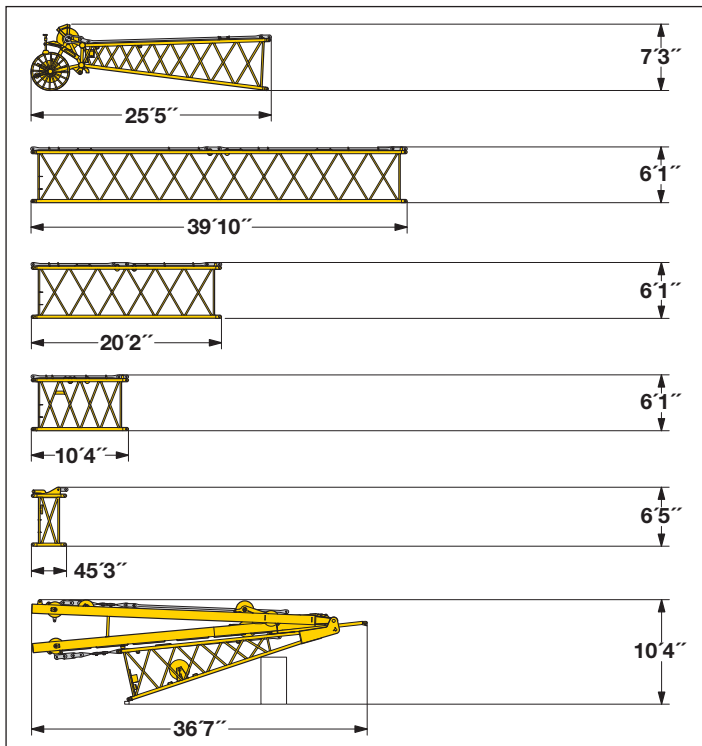

Luffing jib head (No. 1916.21)

Width	6'9"
Weight*	3,400 lbs

Luffing jib section (No. 1916.18) **40 ft**

Width	6'9"
Weight*	2,760 lbs

Luffing jib section (No. 1916.18) **20 ft**

Width	6'9"
Weight*	1,520 lbs

Luffing jib section (No. 2316.20) **10 ft**

Width	6'9"
Weight*	1,210 lbs

L-boom jib section (No. 1916.22) **39.4 inch**

Width	6'9"
Weight*	1,010 lbs

Luffing jib foot with A-frames (No. 1916.22)

Width	6'9"
Weight*	14,110 lbs

Fixed jib (No. 1008.xx)

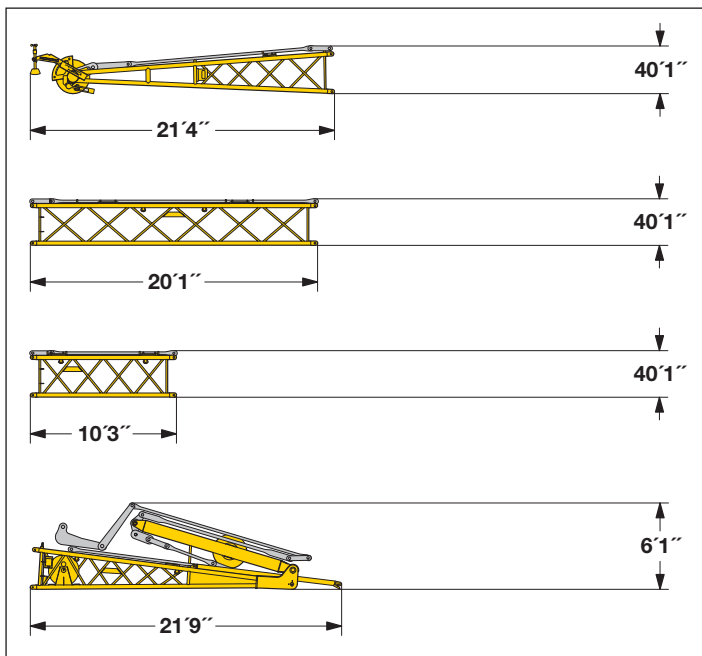

Jib head (No. 1008.20)

Width	3'7"
Weight*	920 lbs

Jib section (No. 1713.18) **20 ft**

Width	3'7"
Weight*	1,005 lbs

Jib section (No. 1008.17) **10 ft**

Width	3'7"
Weight*	660 lbs

Jib foot with A-frame (No. 1008.20)

Width	7'3"
Weight*	4,300 lbs

*) Including pendants

Transport dimensions and weights

Counterweights

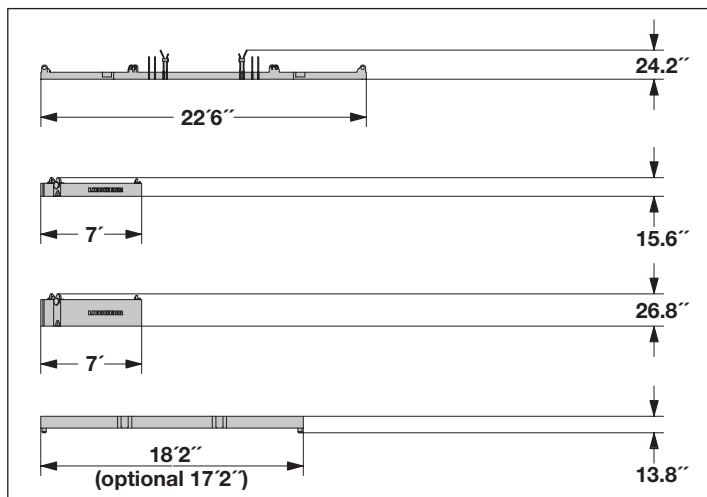

Counterweight **1x**

Width	6'11"
Weight	32,000 lbs

Counterweight **6x**

Width	6'11"
Weight	11,050 lbs

Counterweight **8x**

Width	6'11"
Weight	22,050 lbs

Carbody counterweight **4x**

Width	5'
Weight	31,420 lbs

Mid fall (optional)

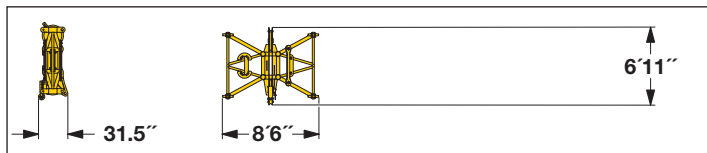

Mid fall section (No. 2316.25) **1.64 ft**

Width	8'6"
Weight	1,550 lbs

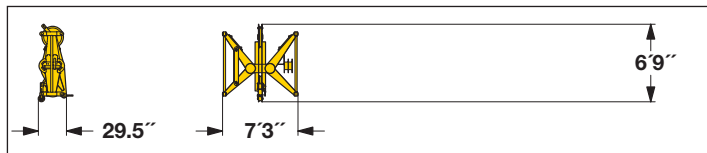

Mid fall section (No. 1916.32) **1.64 ft**

Width	7'3"
Weight	1,580 lbs

Hooks

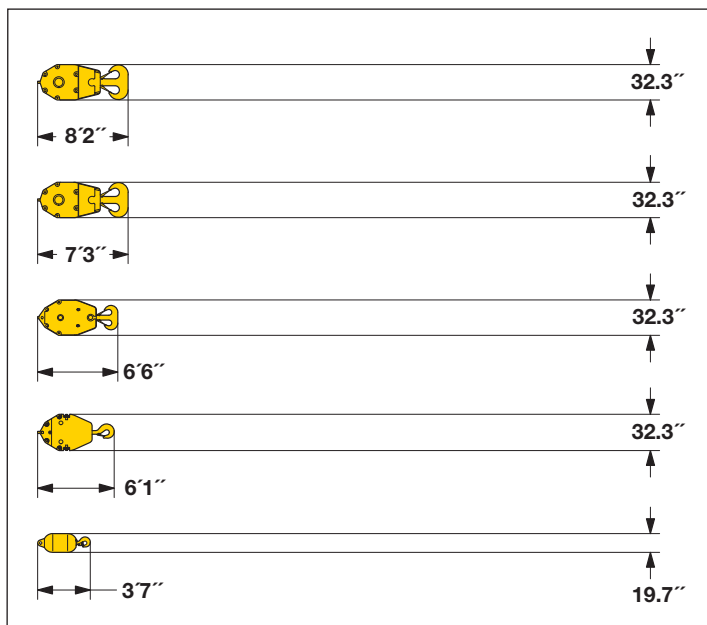

661,400 lbs hook block - 11 sheaves

Width	34.6 inch	48.4 inch
Weight	7,050 lbs	12,130 lbs

330,700 lbs hook block - 7 sheaves

Width	19.7 inch	26 inch	32.3 inch
Weight	3,500 lbs	6,200 lbs	8,800 lbs

220,500 lbs hook block - 5 sheaves

Width	13.4 inch	19 inch	24.4 inch
Weight	2,400 lbs	4,500 lbs	6,600 lbs

110,200 lbs hook block - 1 sheave

Width	11 inch	16.1 inch	21.3 inch
Weight	1,800 lbs	3,500 lbs	5,300 kg

35,300 lbs single hook

Width	19.7 inch
Weight	2,000 lbs

Technical description



Engine

Power rating according to ISO 9249, 390 kW (523 hp) at 1900 rpm

Engine type _____ Liebherr D 856 A7 SCR

Fuel tank _____ 238 gal capacity with continuous level indicator and reserve warning

Engine complies with NRMM exhaust certification EPA/CARB Tier 4i or 97/68 EC Stage IIIB.



Hydraulic system

An axial displacement pump supplies the open loop hydraulic system for boom luffing, jib luffing and travel. The main hoist winches and swing are operated in a closed loop system. All functions can be operated simultaneously. To minimize peak pressure an automatic working pressure cut-off has been installed. All filters are electronically monitored.

The use of synthetic environmentally friendly (biodegradable) oils is possible.

Working pressure _____ max. 5076 PSI

Oil tank capacity _____ 238 gal



Luffing jib winch

Line pull _____ max. 23,600 lbs

Rope diameter _____ 20 mm

Jib luffing _____ 69 sec. from 15° to 78°



Boom winch

Line pull _____ max. 48,800 lbs

Rope diameter _____ 24 mm

Boom up _____ 127 sec. from 15° to 86°



Swing

Consists of rollerbearing with external teeth, swing drive with fixed axial piston hydraulic motor, spring loaded and hydraulically released multi-disc holding brake, planetary gearbox and pinion.

Both swing modes are possible – speed control or free swing.

A multi-disc holding brake acts automatically at zero swing motion.

Swing speed from 0 – 1.8 rpm continuously variable.



Main winches

Line pull (1st layer) _____ max. 48,350 lbf

Line pull (7th layer) _____ 33,750 lbf

Rope diameter _____ 28 mm

Drum diameter _____ 28.7 inch

Rope speed _____ 0 – 453 ft/min

Rope capacity in 7 layers _____ 1,870 ft

The winches are outstanding in their compact design and easy assembly.

Propulsion is via a planetary gearbox in an oil bath.

Load support by the hydraulic system; additional safety factor provided by a spring loaded, multi-disc holding brake.

The main winches use pressure controlled, variable flow hydraulic motors.

This system features sensors that automatically adjust oil flow to provide max. winch speed depending on load.

Option – winch with freefall system:

Clutch and braking functions on the freefall system are provided by a compact designed, low wear and maintenance free multi-disc brake.



Crawlers

Propulsion through axial piston motor, hydraulically released spring loaded multi-disc brake, crawler tracks, hydraulic chain tensioning device.

Flat track shoes _____ 47.2 inch

Flat track shoes (Option) _____ 59.0 inch

Drive speed _____ 0 – 0.8 mph



Control

The control system – developed and manufactured by Liebherr – is designed to withstand extreme environmental conditions such as temperature, vibration and electromagnetic interference and to meet all requirements that are needed in heavy duty crane operation. Complete machine operating data are shown on a high resolution display. Standard operational information is displayed by means of graphical symbols, fault indications are displayed in plain text (more than 15 languages available).

The cranes are equipped with proportional control for all main movements, which can be carried out simultaneously.

The crane is operated with 2 multi-directional joysticks, the right for winch I and boom, the left for winch II and swing control.

Remote control for assembly of counterweight and boom hinge pins. Option:

Bi-directional double T-levers for simultaneous boom and luffing jib operation.

The crawlers are activated by the two foot pedals. Additionally, hand levers can be attached to the pedals.

Complete radio remote control of all crane functions.



Noise emission

Noise emissions correspond with 2000/14/EC directive on noise emission by equipment used outdoors.

Boom combinations

Standard main boom

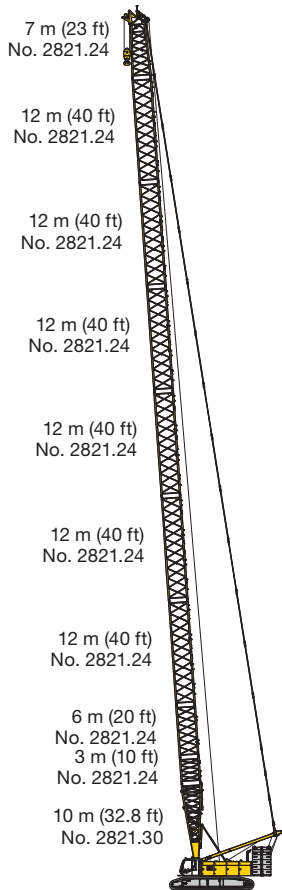

High reach boom

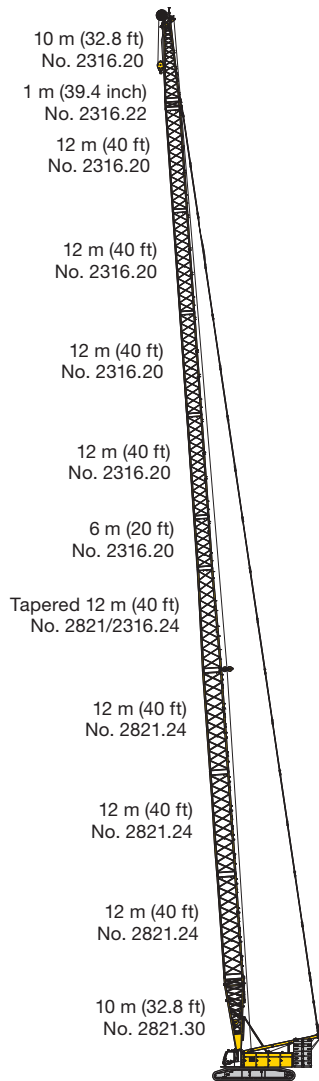

Fixed jib light

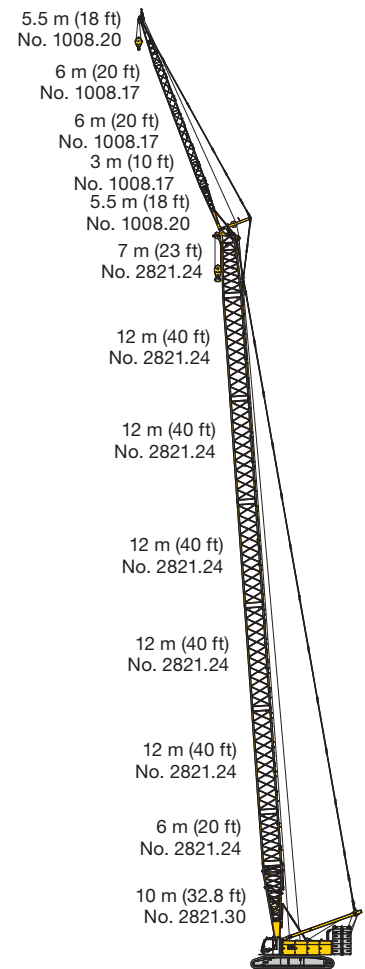

Main boom No.2821.xx — 322 ft

Max. combination — 404 ft

Main boom No.2321.xx — 141 ft

Tapered No.2321/2316.xx — 40 ft

Luffing jib No.2316.xx - 223 ft

Max. combination — 357 ft

Main boom No. 2821.xx — 272 ft

Fixed jib No. 1008.xx — 85 ft

Main boom No. 2821.xx — 282 ft

Fixed jib No. 1008.xx — 56 ft

Boom combinations

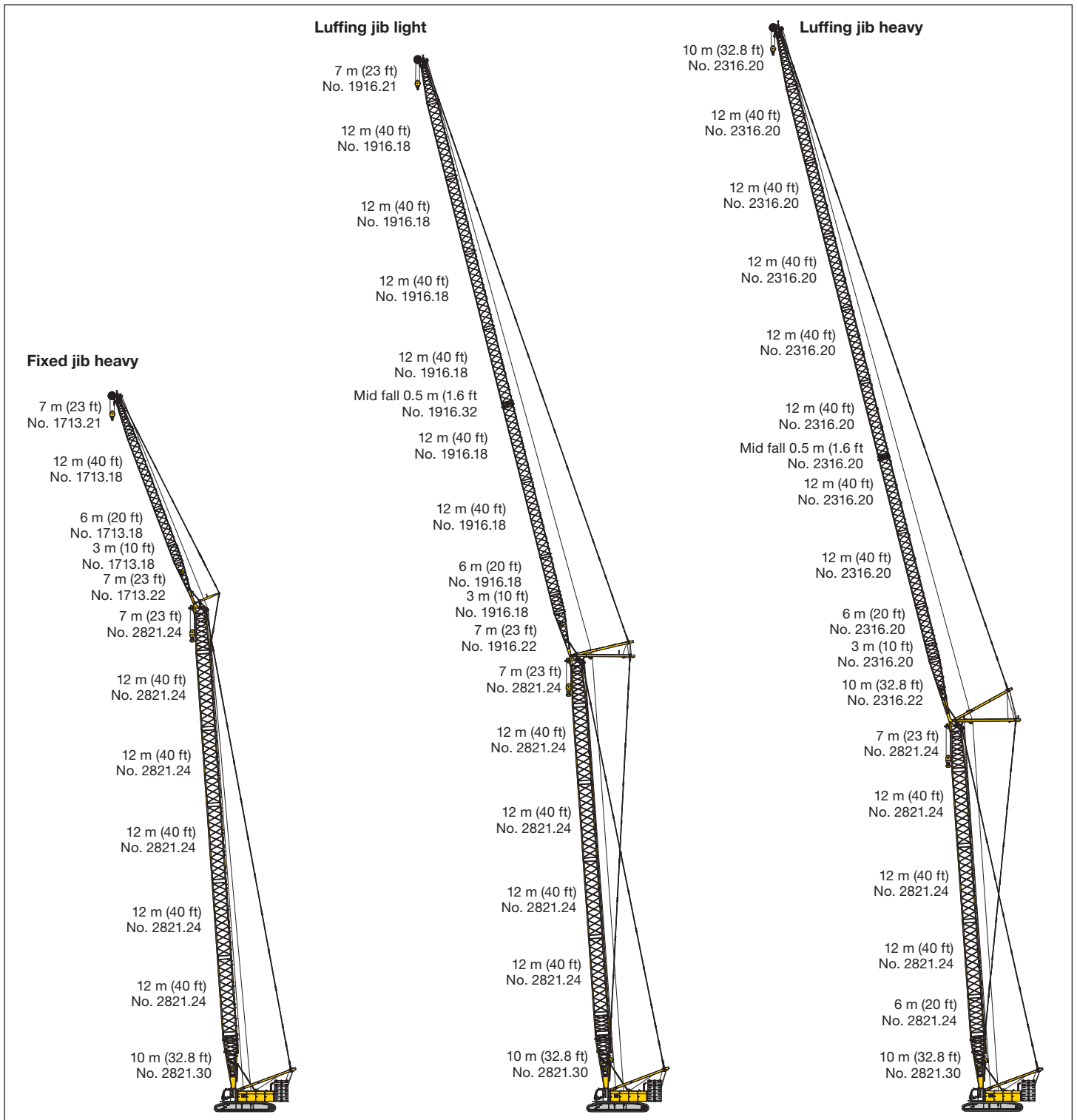

Max. combination — 368 ft

Main boom No. 2821.xx — 253 ft
 Fixed jib No. 1713.xx — 115 ft

Main boom No. 2821.xx — 272 ft
 Fixed jib No. 1713.xx — 76 ft

Max. combination — 535 ft

Main boom No. 2821.xx — 223 ft
 Luffing jib No. 1916.xx — 312 ft

Main boom No. 2821.xx — 243 ft
 Luffing jib No. 1916.xx — 174 ft

Max. combination — 565 ft

Main boom No. 2821.xx — 194 ft
 Luffing jib No. 2316.xx — 371 ft

Main boom No. 2821.xx — 233 ft
 Luffing jib No. 2316.xx — 144 ft

Self assembly system

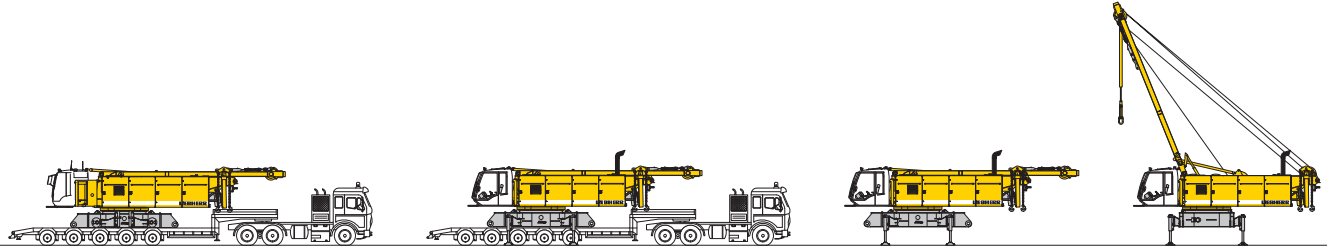

Unloading of basic machine

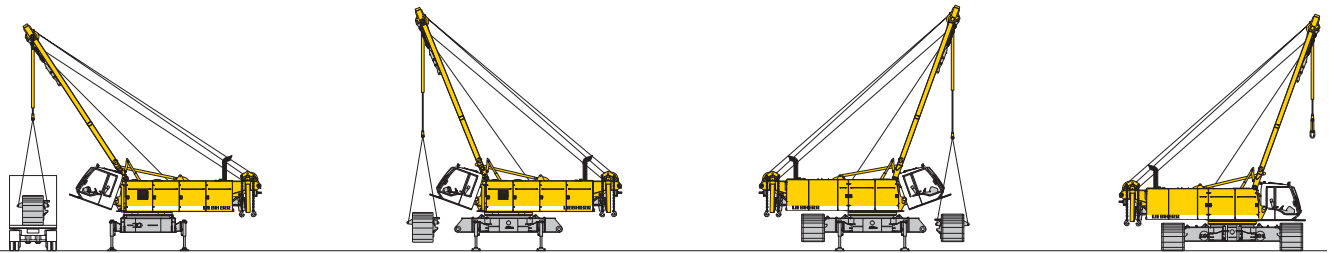

Unloading and assembly of crawlers

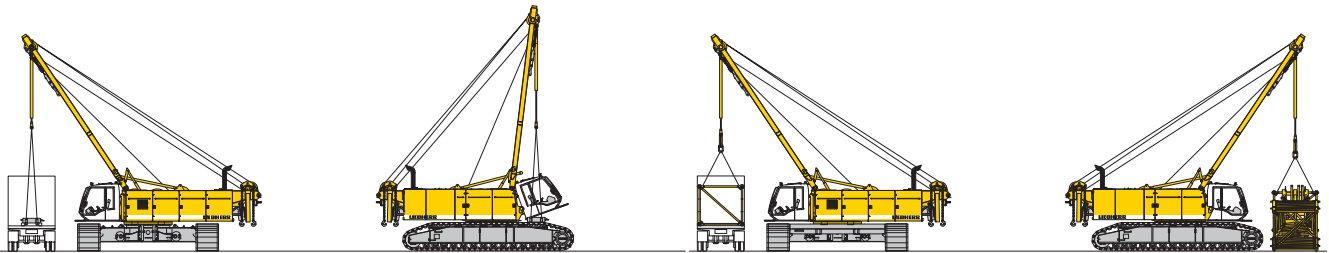

Unloading and assembly of carbody counterweight

Unloading and assembly of boom

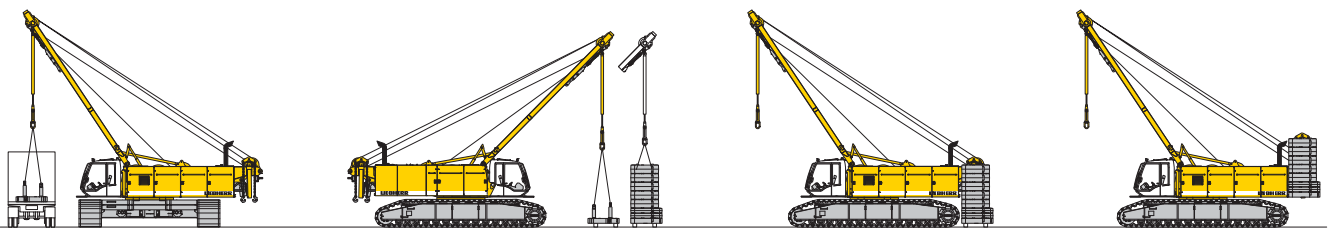

Unloading and assembly of counterweight

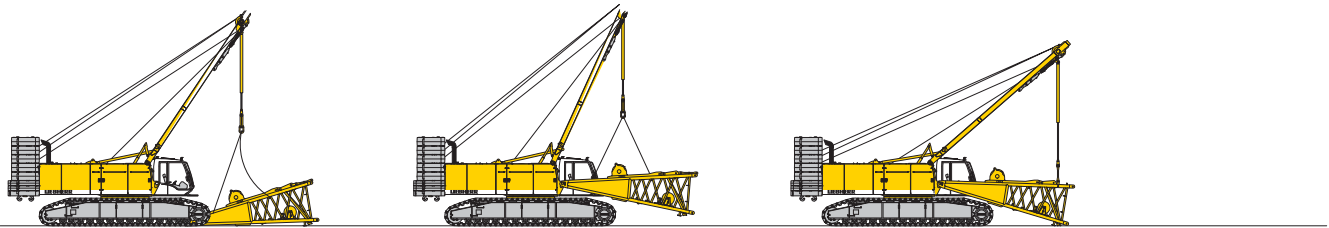

Unloading and assembly of boom foot

Erecting of main boom to working position

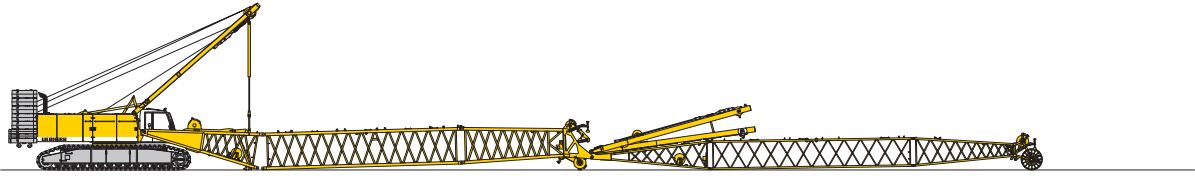

Assembly of boom

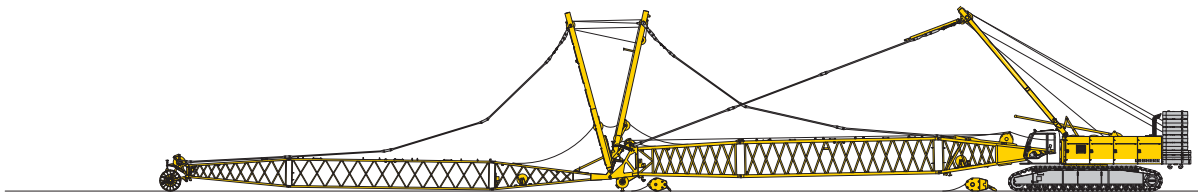

Reeving of hoist and luffing jib ropes

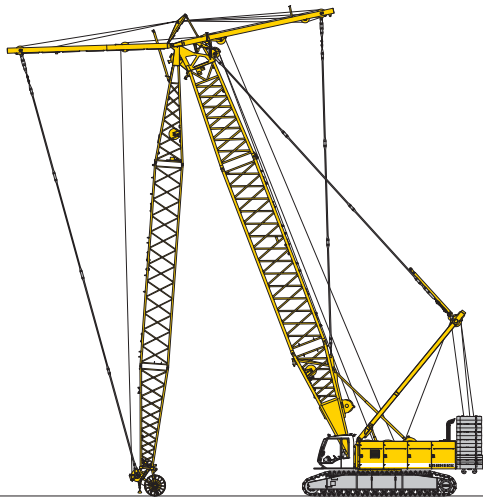

Erecting of main boom and luffing jib

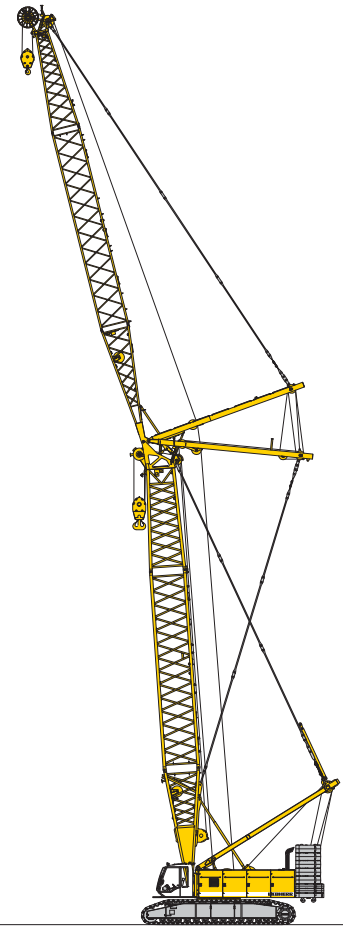

Working position

Lift chart for main boom (No. 2821.xx)

229,300 lbs counterweight and 125,700 lbs carbody counterweight

Captivate in 1000 lbs for boom lengths (66 ft - 312 ft) – with 48,350 lbf winches

Radius	Boom length in (ft)															Radius	
	66	76	85	105	125	144	164	184	203	223	243	262	282	302	312		
(ft)	lbs	lbs	lbs	lbs	lbs	lbs	lbs	lbs	lbs	lbs	lbs	lbs	lbs	lbs	lbs	lbs	(ft)
15	603,2	661,4															15
20	574,2	578,9	578,1	577,4	570,6	526,6											20
25	459,4	459,3	458,5	457,8	456,4	455,4	446,9	419,7	363,6								25
30	379,5	379,4	378,7	378,0	376,6	375,6	374,0	368,6	344,3	311,2	273,2	239,9	205,3				30
35	322,4	322,4	321,6	321,0	319,6	318,5	317,0	315,7	314,1	296,3	261,0	237,6	204,8	177,3	165,4		35
40	274,2	274,7	274,7	274,9	274,7	274,4	274,0	272,9	267,4	261,1	250,9	234,0	202,9	176,4	164,2		40
50	198,7	199,2	199,1	199,2	198,8	198,5	197,9	197,3	196,7	196,0	192,5	188,1	183,6	170,4	160,1		50
60	154,2	154,8	154,7	154,8	154,3	153,9	153,2	152,5	151,8	151,1	150,3	149,3	145,7	142,2	140,3		60
65	138,0	138,7	138,7	138,8	138,3	137,8	137,1	136,4	135,6	134,9	134,0	133,3	131,4	128,2	126,5		65
75		114,0	114,2	114,4	113,8	113,3	112,5	111,9	111,0	110,2	109,3	108,5	107,5	106,0	104,6		75
85			96,1	96,5	96,0	95,5	94,7	94,0	93,0	92,2	91,3	90,4	89,4	88,5	88,0		85
105				71,9	71,6	71,2	70,4	69,6	68,7	67,8	66,8	65,9	64,9	63,9	63,4		105
125					55,6	55,3	54,6	53,8	52,8	52,0	51,0	50,0	49,0	48,0	47,5		125
140						46,6	45,9	45,2	44,2	43,3	42,3	41,3	40,3	39,3	38,8		140
160							36,9	36,3	35,3	34,5	33,4	32,7	31,6	30,6	30,1		160
180								29,5	28,7	27,8	26,8	25,9	24,8	23,8	23,2		180
200									23,2	22,4	21,4	20,5	19,4	18,4	17,9		200
220										17,9	17,0	16,1	15,0	14,0	13,5		220
235											14,2	13,3	12,2	11,3	10,7		235
255												10,0	9,0	8,1	7,6		255
275													6,2	5,3	4,8		275
280														4,7	4,2		280
295														2,9	2,4		295

Lift chart for main boom (No. 2821.xx)

273,400 lbs counterweight and 125,700 lbs carbody counterweight

Capacities in 1000 lbs for boom lengths (66 ft - 322 ft) – with 48,350 lbf winches

Radius	Boom length in (ft)															Radius	
	66	76	85	105	125	144	164	184	203	223	243	262	282	302	322		
(ft)	lbs	lbs	lbs	lbs	lbs	lbs	lbs	lbs	lbs	lbs	lbs	lbs	lbs	lbs	lbs	lbs	(ft)
22,3								419,7									22,3
25							446,9	419,7	363,6								25
30					391,0	386,3	382,5	368,6	344,3	311,2	273,2	239,9	205,3				30
35			346,3	343,1	339,6	334,5	328,2	323,8	319,1	296,3	261,0	237,6	204,8	177,3	155,5		35
40	301,0	301,1	300,4	299,8	296,5	294,2	290,8	283,7	278,6	272,2	250,9	234,0	202,9	176,4	154,6		40
45	260,9	261,4	261,3	261,5	261,1	260,1	257,5	254,8	247,7	241,1	226,5	221,9	201,1	175,5	153,1		45
50	224,9	225,3	225,3	225,4	225,0	224,6	224,0	223,5	222,8	217,4	206,5	202,5	186,8	170,4	152,0		50
60	174,9	175,5	175,4	175,6	175,0	174,6	173,9	173,3	172,5	171,8	171,0	170,2	165,0	153,6	140,7		60
65	156,8	157,5	157,5	157,6	157,1	156,6	155,9	155,2	154,4	153,7	152,8	152,1	151,2	147,2	136,1		65
75		129,9	130,0	130,2	129,6	129,2	128,4	127,7	126,8	126,0	125,1	124,3	123,4	122,5	119,9		75
85			109,8	110,2	109,6	109,2	108,3	107,6	106,7	105,9	104,9	104,1	103,1	102,2	101,2		85
105				82,7	82,4	81,9	81,1	80,4	79,4	78,6	77,6	76,6	75,6	74,7	73,6		105
125					64,4	64,2	63,4	62,7	61,7	60,8	59,8	58,9	57,8	56,8	55,8		125
140						54,4	53,7	53,0	52,0	51,1	50,1	49,1	48,1	47,1	46,0		140
160							43,6	43,0	42,1	41,2	40,2	39,2	38,1	37,1	36,0		160
180								35,3	34,5	33,6	32,8	31,8	30,7	29,7	28,6		180
200									28,5	27,7	26,7	25,8	24,7	23,7	22,6		200
220										22,8	21,8	20,9	19,8	18,8	17,7		220
235											18,7	17,8	16,7	15,7	14,6		235
255												14,2	13,2	12,2	11,1		255
275													10,1	9,1	8,0		275
295														6,2	4,7		295
310															2,4		310

L - boom high reach (No. 2821/2316.xx) 236 ft - 404 ft

Working range 78° - 15°

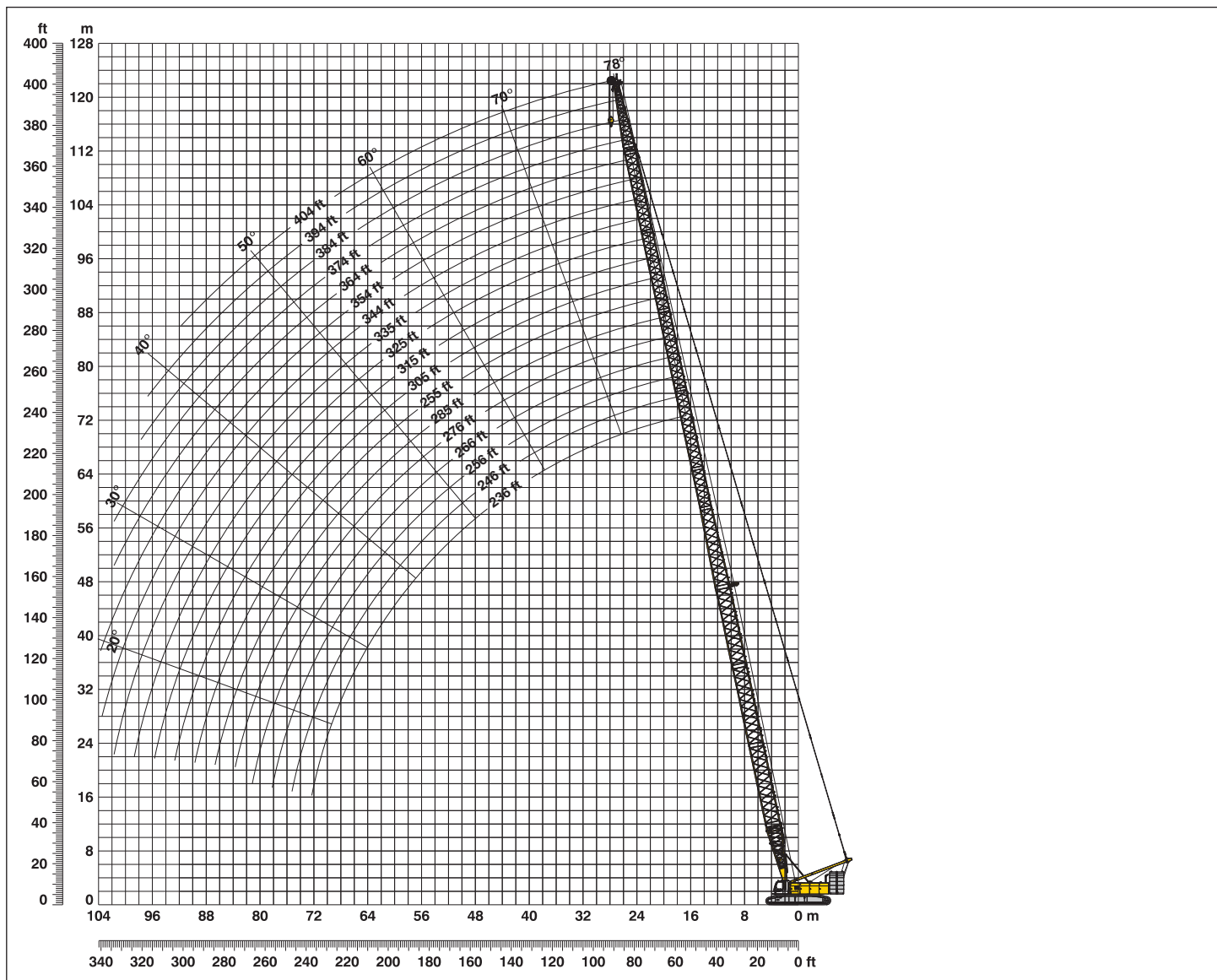

L - boom configuration with 151 ft main boom (No. 2821/2316.xx)

Configuration for L - boom lengths between 236 ft and 404 ft

	Length*	Amount of boom extensions																	
		1	1	1	1	1	1	1	1	1	1	1	1	1	1	1	1	1	1
Boom foot	33 ft	1	1	1	1	1	1	1	1	1	1	1	1	1	1	1	1	1	1
Boom insert	40 ft	3	3	3	3	3	3	3	3	3	3	3	3	3	3	3	3	3	3
Tapered	40 ft	1	1	1	1	1	1	1	1	1	1	1	1	1	1	1	1	1	1
Luffing insert	10 ft	1		1		1		1		1		1		1		1		1	
Luffing insert	20 ft		1	1			1	1			1	1			1	1			1
Luffing insert	40 ft				1	1	1	1	2	2	2	2	3	3	3	3	4	4	4
Luffing insert	3.2 ft	1	1	1	1	1	1	1	1	1	1	1	1	1	1	1	1	1	1
Luffing jib head	33 m	1	1	1	1	1	1	1	1	1	1	1	1	1	1	1	1	1	1
Max. L - boom length (ft)		236	246	256	266	276	285	295	305	315	325	335	344	354	364	374	384	394	404

*Actual lengths of boom sections are metric (e.g. 3m, 6m, 7m, 12m). The figures shown above are approximate conversions to feet.

L - boom high reach (No. 2821/2316.xx) **236 ft - 404 ft**

Working range 86° - 15°

Capacities in 1000 lbs for boom lengths (236 ft - 404 ft) – with 48,350 lbf winches

Radius	Boom length in (ft)															Radius	
	236	276	285	295	305	315	325	335	344	354	364	374	384	394	404		
(ft)	lbs	lbs	lbs	lbs	lbs	lbs	lbs	lbs	lbs	lbs	lbs	lbs	lbs	lbs	lbs	lbs	(ft)
56	141,9																56
65	120,9	115,0															65
70	110,2	106,9	102,6	102,3													70
75	101,7	98,4	97,5	96,4	93,5	87,1	87,2										75
80	95,2	90,6	89,7	89,3	88,8	84,5	84,1	71,4	77,4								80
85	89,7	84,0	83,1	82,5	82,0	79,3	80,7	69,1	75,5	71,1	65,3						85
90	84,9	78,9	77,7	76,8	76,3	73,9	74,8	66,8	72,6	69,6	64,0	57,4	53,5	47,4			90
95	81,0	74,6	73,4	72,1	71,4	69,4	69,6	64,7	67,7	65,6	61,8	56,3	52,5	46,3	42,3		95
100	77,7	70,9	69,5	68,4	67,6	65,6	65,3	62,9	63,4	61,6	58,5	54,1	51,1	45,4	41,5		100
110	68,4	64,8	63,1	62,0	61,2	59,6	58,6	60,1	56,8	55,1	53,2	50,4	48,2	42,9	39,2		110
120	61,2	59,1	58,4	57,1	56,3	54,5	53,3	54,6	51,7	50,3	49,3	47,6	46,0	41,0	37,3		120
130	55,4	52,8	52,3	51,9	52,1	50,8	49,1	50,0	47,4	45,9	44,9	44,0	43,3	39,5	35,8		130
140	49,8	47,9	47,3	46,6	46,6	46,0	45,2	46,6	44,1	42,5	41,4	40,4	39,6	36,8	33,7		140
150	45,5	43,7	43,6	42,4	42,2	41,5	40,7	41,8	40,3	39,5	38,7	37,5	36,6	34,5	31,6		150
160	41,5	39,5	39,4	38,7	38,8	37,9	37,1	37,7	36,3	35,4	35,0	34,6	34,4	32,8	29,9		160
170	37,6	36,1	35,8	35,0	35,0	34,6	34,2	34,4	33,0	32,0	31,5	31,0	30,7	30,2	28,4		170
180	34,4	33,4	32,9	31,8	31,7	31,1	30,8	31,8	30,4	29,3	28,5	28,0	27,6	26,9	25,6		180
190	31,9	30,2	30,5	29,4	29,0	28,1	27,8	28,5	27,6	27,0	26,4	25,5	25,0	24,2	23,1		190
200	28,9	27,5	27,6	26,9	27,0	25,7	25,4	25,6	24,8	24,1	23,7	23,5	23,0	22,4	21,2		200
210	26,3	25,3	25,1	24,3	24,4	23,7	23,4	23,2	22,4	21,6	21,2	20,9	20,6	20,6	20,0		210
220	24,0	23,2	23,0	22,1	22,1	21,4	21,1	21,2	20,4	19,5	19,0	18,6	18,3	18,1	17,7		220
230	21,6	20,9	20,9	20,3	20,1	19,4	19,0	18,9	18,4	17,8	17,2	16,6	16,3	16,0	15,5		230
235	20,4	19,9	19,9	19,3	19,3	18,5	18,1	17,9	17,4	16,8	16,4	15,8	15,4	15,0	14,5		235
240		19,0	18,9	18,3	18,5	17,7	17,2	16,9	16,5	15,8	15,5	15,0	14,6	14,1	13,6		240
250		17,3	17,1	16,5	16,6	16,2	15,7	15,2	14,7	14,1	13,7	13,3	13,1	12,5	11,9		250
260		15,5	15,6	14,9	14,9	14,4	14,1	13,8	13,3	12,5	12,1	11,6	11,4	11,0	10,5		260
270		13,7	13,9	13,4	13,4	12,9	12,5	12,2	12,0	11,2	10,7	10,1	9,8	9,4	9,0		270
280			12,3	11,9	12,1	11,5	11,1	10,7	10,5	9,9	9,6	8,9	8,4	8,0	7,6		280
290				10,4	10,6	10,2	9,9	9,4	9,2	8,6	8,3	7,8	7,2	6,7	6,4		290
300					9,2	8,9	8,6	8,2	8,0	7,4	7,1	6,5	6,1	5,7	5,3		300
310						7,5	7,4	7,0	6,9	6,3	5,9	5,4	4,8	4,7	4,4		310
320							6,2	5,8	5,0	5,3	4,9	4,3	3,5	3,7	3,6		320
330								4,6	3,1	3,9	4,0	3,4	2,4	2,7	2,9		330
335									2,2	3,2	3,5	3,0		2,3	2,6		335
340										2,5	3,0	2,8			2,2		340
350											2,0	2,6					
365												2,3					

Working range - luffing jib (No. 2316.xx) 78° - 15°

Main boom 88° - 45°

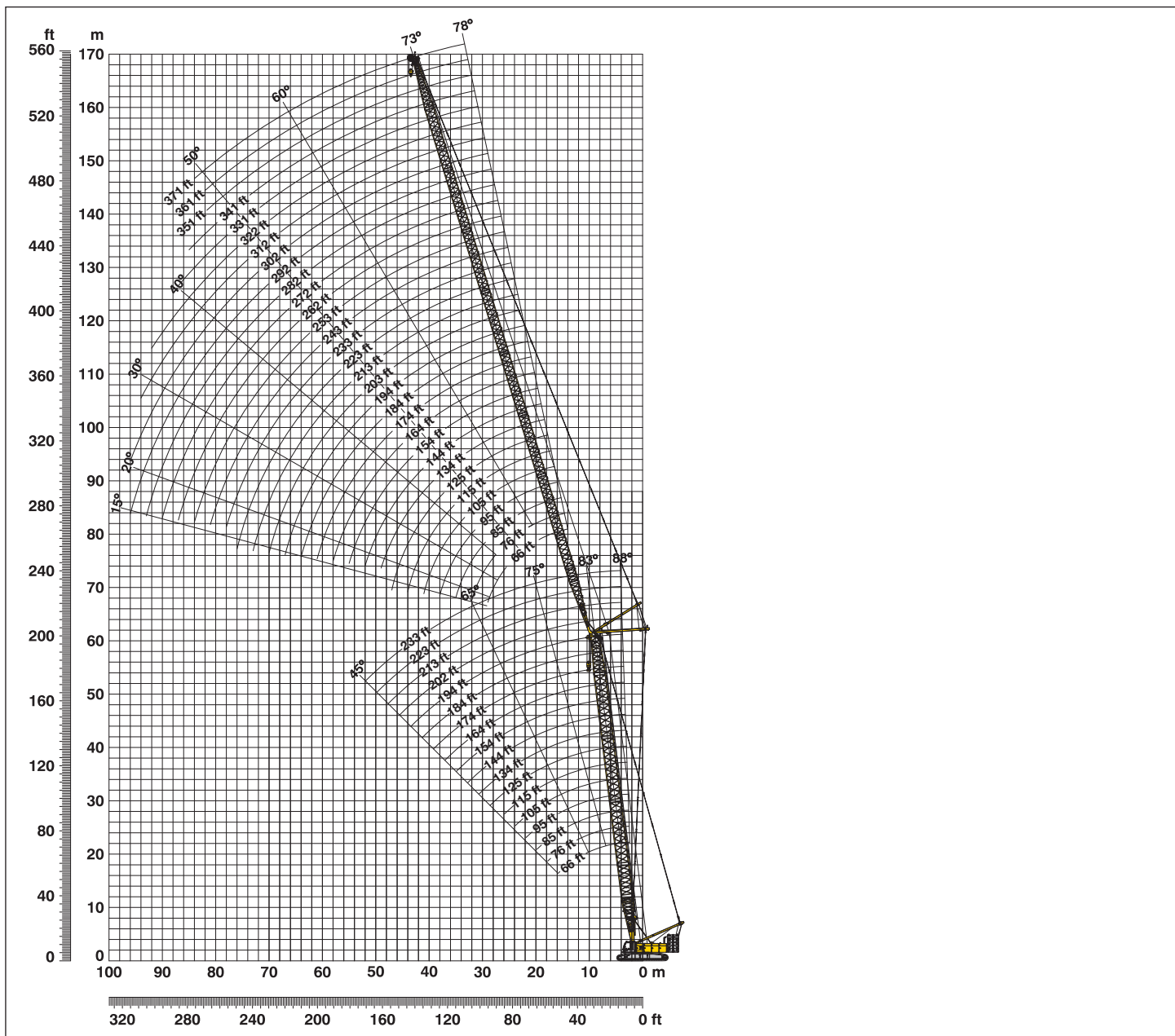

Boom configuration for main boom lengths (66 ft - 233 ft) – see table 1 on page 10

Jib configuration for jib lengths (66 ft - 371 ft)

	Length*	Amount of luffing jib extensions																																											
Luffing jib foot	33 ft	1	1	1	1	1	1	1	1	1	1	1	1	1	1	1	1	1	1	1	1	1	1	1	1	1	1	1	1	1	1	1	1	1	1	1	1	1	1	1	1	1	1		
Luffing jib insert	10 ft			1	1	1	1	1	1	1	1	1	1	1	1	1	1	1	1	1	1	1	1	1	1	1	1	1	1	1	1	1	1	1	1	1	1	1	1	1	1	1	1		
Luffing jib insert	20 ft				1	1	1	1	1	1	1	1	1	1	1	1	1	1	1	1	1	1	1	1	1	1	1	1	1	1	1	1	1	1	1	1	1	1	1	1	1	1	1	1	
Luffing jib insert	40 ft					1	1	1	1	1	2	2	2	2	3	3	3	3	3	4	4	4	4	4	5	5	5	5	5	6	6	6	6	6	6	7	7	7	7	7	7	7	7	7	7
Luffing jib head	33 ft	1	1	1	1	1	1	1	1	1	1	1	1	1	1	1	1	1	1	1	1	1	1	1	1	1	1	1	1	1	1	1	1	1	1	1	1	1	1	1	1	1	1	1	1
Luffing jib length (ft)		66	76	85	95	105	115	125	134	144	154	164	174	184	194	203	213	223	233	243	253	262	272	282	292	302	312	322	331	341	351	361	371	371	371	371	371	371	371	371	371	371	371	371	

*Actual lengths of boom sections are metric (e.g. 3m, 6m, 7m, 12m). The figures shown above are approximate conversions to feet.

Lift chart - luffing jib (No. 2316.xx)

Main boom angle 88°

Main boom 66 ft

Radius	Jib length in (ft)							
	66	105	164	203	243	282	322	371
(ft)	lbs	lbs	lbs	lbs	lbs	lbs	lbs	lbs
45		165,4						
50		142,3	141,6					
55		123,5	121,3	110,0				
60	115,7	109,4	107,5	107,4				
65	103,5	99,2	95,3	94,6	86,7			
70	94,7	90,5	86,5	85,7	85,0			
75	33,4	83,3	78,7	77,2	76,9	61,3		
80		77,5	71,8	70,3	69,8	60,8	42,1	
100		57,9	54,2	51,6	50,4	48,9	39,4	26,3
110		51,4	48,3	45,4	43,6	42,1	36,7	24,9
170			28,6	26,5	24,2	22,2	20,3	16,2
205				19,9	17,9	15,6	13,3	9,4
240					13,3	11,4	9,1	2,4
245					12,7	10,9	8,6	
280						7,7	5,7	
320							2,8	

Main boom 134 ft

Radius	Jib length in (ft)							
	66	105	164	203	243	282	322	371
(ft)	lbs	lbs	lbs	lbs	lbs	lbs	lbs	lbs
28,7	258,0							
40	239,2	221,4						
50	198,7	191,7	136,0					
60	170,3	167,5	131,4	97,6				
70	144,4	148,7	124,3	94,7	71,3			
75	121,0	139,7	121,7	93,0	70,5	53,1		
85		122,3	111,7	89,1	68,5	52,4	37,9	
95		104,6	104,8	84,9	65,9	51,0	37,1	24,0
110		79,1	87,3	78,6	62,6	48,7	35,1	22,9
140			63,1	62,3	55,3	44,4	31,6	20,5
170			42,2	47,8	46,8	39,9	28,8	18,4
205				31,9	35,1	34,2	26,1	16,6
245					21,8	24,5	21,5	14,9
285						14,0	16,6	7,2
310							11,2	2,1
320							9,1	

Main boom 164 ft

Radius	Jib length in (ft)							
	66	105	164	203	243	282	322	371
(ft)	lbs	lbs	lbs	lbs	lbs	lbs	lbs	lbs
29,7	252,2							
40	211,6	188,0						
55	164,9	158,6	115,4					
60	154,3	148,4	112,3	85,8				
70	135,4	133,4	105,9	83,2	64,0			
75	121,1	126,1	103,3	81,9	63,4	48,0		
85		114,8	95,9	77,7	61,4	47,6	35,0	
95		102,8	90,4	74,1	58,9	46,2	34,8	22,1
110		82,1	80,1	68,3	55,7	43,9	33,2	21,4
140			62,6	57,4	49,1	38,2	30,3	19,4
170			43,6	46,8	42,5	33,1	27,8	17,5
205				32,9	34,7	28,5	25,1	15,8
245					22,7	24,4	21,2	14,3
285						14,5	16,5	7,4
310							11,2	2,4
320							9,0	

Main boom 194 ft

Radius	Jib length in (ft)							
	66	105	164	203	243	282	322	371
(ft)	lbs	lbs	lbs	lbs	lbs	lbs	lbs	lbs
30,8	213,9							
40	186,0	155,1						
55	148,0	139,2	99,5					
60	139,4	131,1	96,7	75,2				
70	123,6	119,0	91,1	73,3	56,9			
75	117,3	112,8	88,7	71,9	56,6			
80		107,7	85,8	70,0	55,5	43,6		
85		103,6	82,6	68,2	54,6	43,3	32,5	
95		93,8	77,7	65,0	48,9	42,0	31,9	20,4
115		73,4	66,4	58,3	42,1	39,2	30,8	19,6
170			43,0	41,4	32,9	28,1	26,1	16,7
210				30,5	29,5	24,3	20,8	14,9
245					22,3	21,6	18,1	13,6
285						14,6	16,3	7,4
310							11,4	2,6
320							9,3	

Main boom 213 ft

Radius	Jib length in (ft)					
	66	105	164	203	243	262
(ft)	lbs	lbs	lbs	lbs	lbs	lbs
31,5	185,2					
40	169,4	136,8				
55	137,2	123,9	89,7			
65	122,0	113,0	85,6	68,7		
70	115,5	108,6	82,6	67,2	52,5	
75	110,4	103,0	80,3	65,8	52,4	46,1
80		98,3	77,9	64,1	51,4	45,9
115		72,1	60,7	53,5	38,5	34,9
140			50,9	45,6	34,6	31,6
170			42,1	38,1	29,8	27,6
180				35,9	28,9	26,4
210				30,2	27,1	24,5
220					26,5	24,1
245					22,0	21,9
260						19,2
265						18,3

Main boom 233 ft

Radius	Jib length in (ft)					
	135	144				
(ft)	lbs	lbs				
46,5	97,9					
50	97,6	92,0				
60	91,5	88,2				
70	85,3	82,1				
80	79,0	76,0				
90	73,0	71,2				
100	67,4	65,5				
110	62,5	61,2				
115	59,9	58,9				
120	57,5	56,5				
125	55,4	54,2				
135	51,9	50,3				
140	50,3	48,8				
145	48,6	47,3				
150		45,9				
155		44,4				

Capacities in 1000 lbs with luffing jib (No. 2316.xx) 273,400 lbs counterweight + 125,700 lbs carbody counterweight. Above lift chart is for reference only. For actual lift duty and complete chart with all available configurations please refer to lift chart in operator's cab or manual.

Lift chart - luffing jib (No. 2316.xx)

Main boom angle 83°

Main boom 66 ft

Radius	Jib length in (ft)							
	66	105	164	203	243	282	322	371
(ft)	lbs	lbs	lbs	lbs	lbs	lbs	lbs	lbs
37,7	257,9							
50	188,8	179,6						
70	110,9	104,7	105,8					
75	101,4	93,9	93,7					
80		85,2	84,9	82,6				
90		73,0	70,1	70,1	65,5			
105		59,9	56,0	54,8	54,3	53,2		
115		52,9	48,9	47,9	46,9	47,9	36,9	
130			41,7	39,4	38,1	38,5	34,5	23,0
140			37,7	35,1	33,9	33,4	32,1	22,4
170			30,0	27,0	24,8	24,8	22,3	18,2
210				19,4	17,6	16,3	14,0	11,7
250					12,5	11,3	9,0	6,6
285						7,9	6,0	2,9
290							5,6	2,5
325							3,0	

Main boom 134 ft

Radius	Jib length in (ft)							
	66	105	164	203	243	282	322	371
(ft)	lbs	lbs	lbs	lbs	lbs	lbs	lbs	lbs
46,1	233,1							
60	182,7	181,3						
75	138,0	136,9	130,1					
85	118,2	117,4	115,1					
90		109,5	107,2	97,9				
100		96,3	94,1	92,5	71,0			
110		85,8	83,7	82,1	69,8	50,0		
125		73,3	71,5	69,9	66,5	48,7	33,9	
140			62,1	60,6	59,1	46,5	32,5	21,0
180			45,1	43,8	42,3	40,7	28,9	18,4
220				31,8	32,0	30,4	25,9	16,3
255					24,3	24,1	22,0	14,9
295						15,5	17,3	6,8
315							13,6	2,7
320							12,6	
330							10,5	

Main boom 164 ft

Radius	Jib length in (ft)							
	66	105	164	203	243	282	322	371
(ft)	lbs	lbs	lbs	lbs	lbs	lbs	lbs	lbs
49,7	201,0							
65	163,1	159,2						
80	126,1	124,9	116,4					
90	109,0	108,2	105,7	86,2				
105		89,7	87,4	83,0	63,7			
115		80,3	78,1	76,5	62,6	46,6		
125		72,5	70,5	68,9	60,8	45,9	32,4	
130		69,0	67,1	65,6	59,6	45,3	32,4	
140			61,2	59,7	57,3	44,0	31,7	20,1
185			42,9	41,5	40,0	37,3	27,7	17,5
225				31,3	30,3	28,7	25,1	15,7
240					27,5	26,0	24,1	15,1
260					23,4	22,8	21,3	14,4
300						15,2	16,3	6,6
320							12,9	2,6
335							10,2	

Main boom 194 ft

Radius	Jib length in (ft)							
	66	105	164	203	243	282	322	371
(ft)	lbs	lbs	lbs	lbs	lbs	lbs	lbs	lbs
53,3	184,0							
65	156,1	144,8						
85	115,5	114,3	98,9					
95	100,7	99,8	93,7	75,1				
110		83,5	81,2	72,0	55,9			
120		75,1	72,9	68,0	53,9	43,0		
130		68,1	66,0	64,0	52,3	42,4	30,8	
145			57,6	56,0	45,7	40,7	30,1	19,0
160			50,9	49,3	42,2	38,2	28,8	18,4
190			40,6	39,3	37,7	33,0	26,5	16,7
225				31,0	29,6	27,4	23,8	15,2
265					22,5	21,5	19,6	13,7
280						19,5	17,8	11,8
305						14,7	15,2	6,2
325							12,1	2,4
340							9,6	

Main boom 213 ft

Radius	Jib length in (ft)					
	66	105	164	203	243	262
(ft)	lbs	lbs	lbs	lbs	lbs	lbs
55,7	168,5					
70	139,0	132,6				
85	114,4	111,0	89,0			
95	99,8	98,7	86,1			
100		92,8	84,1	68,0		
110		82,6	77,2	65,9	51,7	
115		78,3	74,5	64,6	50,9	45,3
130		67,4	65,2	59,7	48,0	43,0
160			50,2	48,7	38,6	35,3
190			40,1	38,7	35,9	32,5
200				36,1	34,3	32,0
225				30,6	29,1	28,4
240					26,4	25,7
265					22,5	21,8
280						19,9
285						18,9

Main boom 233 ft

Radius	Jib length in (ft)			
	135	144		
(ft)	lbs	lbs		
78,2	95,8			
85	93,6	89,7		
90	90,5	87,6		
100	83,5	81,6		
110	76,9	76,3		
120	70,4	69,4		
125	67,9	66,6		
130	65,1	64,3		
135	62,4	61,9		
140	59,7	59,4		
145	57,1	57,0		
150	54,8	54,6		
155	52,5	52,4		
160	50,5	50,3		
165	48,5	48,4		
175		44,8		

Capacities in 1000 lbs with luffing jib (No. 2316.xx) 273,400 lbs counterweight + 125,700 lbs carbody counterweight. Above lift chart is for reference only. For actual lift duty and complete chart with all available configurations please refer to lift chart in operator's cab or manual.

Lift chart - luffing jib (No. 2316.xx)

Main boom angle 75°

Main boom 66 ft

Radius	Jib length in (ft)							
	66	105	164	203	243	282	322	371
(ft)	lbs	lbs	lbs	lbs	lbs	lbs	lbs	lbs
60	181,2							
75	122,9	122,7						
85	100,1	97,7						
100		75,0	73,9					
115		63,3	58,6	55,6				
125		55,2	50,6	50,0				
135			45,1	44,1	44,2			
150			38,7	36,3	36,5	33,6		
165			33,8	31,5	30,5	30,9	26,1	
180			30,3	27,6	27,0	26,1	23,8	
185				26,5	26,1	24,5	22,3	16,3
220				19,6	19,1	16,7	14,4	12,0
255					13,9	12,1	9,3	6,7
295						8,0	5,4	2,7
300							5,1	2,2
335							3,0	

Main boom 134 ft

Radius	Jib length in (ft)							
	66	105	164	203	243	282	322	371
(ft)	lbs	lbs	lbs	lbs	lbs	lbs	lbs	lbs
75	129,6							
90	103,7	102,1						
105	85,9	84,7						
115		75,8	73,1					
135		62,3	59,9	58,1				
140		59,6	57,2	55,5				
150			52,5	50,7	49,0			
165			46,5	44,8	43,1	41,3		
185			40,0	38,4	36,8	35,0	28,5	
200			36,0	34,6	33,0	31,3	27,9	
205				33,4	31,8	30,1	27,5	17,0
235				27,5	25,9	24,3	22,6	15,9
275					20,1	18,6	17,0	13,9
310						14,8	13,2	8,2
335							11,0	2,7
350							9,8	

Main boom 164 ft

Radius	Jib length in (ft)							
	66	105	164	213	243	282	322	371
(ft)	lbs	lbs	lbs	lbs	lbs	lbs	lbs	lbs
85	107,7							
100	88,4	86,7						
110	78,6	77,2						
125		66,1	63,3					
145		55,0	52,5	50,1				
150		52,7	50,3	47,9				
160			46,3	44,0	42,7			
175			41,2	39,0	37,7	35,5		
190			37,0	34,8	33,6	31,6	27,4	
205			33,4	31,3	30,2	28,4	25,3	
210				30,3	29,1	27,4	24,3	16,2
255				22,6	21,5	19,9	17,5	13,9
285					17,7	16,2	14,2	10,7
320						12,8	11,2	6,2
340							9,6	2,6
360							8,0	

Main boom 194 ft

Radius	Jib length in (ft)							
	66	105	164	213	243	282	322	371
(ft)	lbs	lbs	lbs	lbs	lbs	lbs	lbs	lbs
90	96,8							
105	80,3	66,4						
120	68,1	66,7						
130		60,5	57,5					
155		48,6	46,0	43,5				
160		46,6	44,1	41,7				
165			42,4	40,0	38,2			
180			37,8	35,5	34,0	30,7		
200			32,8	30,6	29,4	26,4	23,1	
215			29,7	27,6	26,4	23,7	20,5	
220				26,7	25,5	22,8	19,7	15,2
265				19,9	18,8	16,9	14,0	10,2
290					16,0	14,4	11,6	7,9
330						10,8	8,6	4,3
345							7,6	2,3
370							5,6	

Main boom 213 ft

Radius	Jib length in (ft)					
	66	105	164	213	243	262
(ft)	lbs	lbs	lbs	lbs	lbs	lbs
95	88,1					
115	69,9	68,1				
125	63,0	61,5				
135		56,0	52,9			
155		47,1	44,4			
160		45,2	42,6	39,6		
170			39,3	36,7	34,2	
180			36,5	34,0	31,8	30,1
200			31,7	29,3	27,5	25,9
220			27,6	25,5	24,0	22,5
240				22,3	21,1	19,7
265				18,9	17,8	16,8
280					16,1	15,3
295					14,6	13,8
300						13,4
315						12,0

Main boom 233 ft

Radius	Jib length in (ft)			
	135	144		
(ft)	lbs	lbs		
127,6	56,1			
135	52,3	52,0		
140	49,9	49,7		
145	47,8	47,5		
150	45,8	45,5		
155	43,9	43,7		
160	42,2	41,9		
165	40,5	40,3		
170	39,0	38,8		
175	37,5	37,3		
180	36,1	35,9		
185	34,9	34,7		
190	33,6	33,4		
195	32,4	32,3		
200	30,1	31,2		
210		27,0		

Capacities in 1000 lbs with luffing jib (No. 2316.xx) 273,400 lbs counterweight + 125,700 lbs carbody counterweight. Above lift chart is for reference only. For actual lift duty and complete chart with all available configurations please refer to lift chart in operator's cab or manual.

Lift chart - luffing jib (No. 2316.xx)

Main boom angle 65°

Main boom 66 ft

Radius	Jib length in (ft)							
	66	105	164	213	243	282	322	371
(ft)	lbs	lbs	lbs	lbs	lbs	lbs	lbs	lbs
80	121,9							
100	81,5	77,0						
135		46,8	45,5					
165			30,8	31,3				
180			28,0	25,4	23,8			
195			24,2	21,3	20,0			
200				20,0	18,8	15,0		
225				15,8	14,0	11,9	9,3	
240				13,8	11,9	9,9	7,6	
255					10,5	7,9	5,7	4,4
260					10,0	7,4	5,3	4,0
270					9,0	6,4	4,2	2,0
280						5,8	3,3	
295						4,8	2,1	
300						4,5		
305						4,2		

Main boom 134 ft

Radius	Jib length in (ft)							
	66	105	164	203	243	282	322	371
(ft)	lbs	lbs	lbs	lbs	lbs	lbs	lbs	lbs
104,8	66,4							
125	64,1							
130		59,5						
165		44,2	41,6					
185			35,7	33,9				
210			30,1	28,4	26,6			
220			28,2	26,5	24,7			
230				24,8	23,1	21,2		
255				21,1	19,5	17,7	15,5	
260				20,5	18,8	17,1	14,9	
280					16,5	14,8	12,8	9,1
300					14,5	12,8	10,9	7,4
320						11,1	9,4	5,9
335						9,9	8,2	4,9
360							6,1	2,3
375							5,0	

Main boom 164 ft

Radius	Jib length in (ft)							
	66	105	164	203	243	282	322	371
(ft)	lbs	lbs	lbs	lbs	lbs	lbs	lbs	lbs
117,3	65,1							
140	52,3	50,6						
175		38,1	35,3					
180		36,7	34,0					
200			29,5	27,6				
220			25,8	24,0	22,0			
235			23,3	21,6	19,8			
245				20,2	18,4	16,1		
265				17,8	16,0	13,9	10,9	
275				16,6	15,0	12,9	10,0	
295					13,0	11,2	8,3	4,6
310					11,7	10,0	7,2	3,6
335						7,9	5,5	2,1
350						6,7	4,3	
360							3,6	
380							2,2	

Main boom 194 ft

Radius	Jib length in (ft)							
	66	105	164	203	243	282	322	
(ft)	lbs	lbs	lbs	lbs	lbs	lbs	lbs	
129,8	53,4							
150	44,6							
155		41,0						
190		31,5	28,6					
210			24,8	22,7				
235			20,9	19,1	16,6			
245			19,6	17,8	15,4			
250				17,2	14,9			
255				16,6	14,4	11,3		
280				14,0	12,1	9,2	6,2	
285				13,6	11,8	8,8	5,8	
295					10,9	8,1	5,1	
300					10,5	7,7	4,8	
320					8,9	6,4	3,6	
340						4,9	2,3	
360						3,5		

Main boom 213 ft

Radius	Jib length in (ft)						
	66	105	164	203	243	262	
(ft)	lbs	lbs	lbs	lbs	lbs	lbs	
138,1	46,7						
160	38,7						
161		36,6					
195		28,4	25,3				
200		27,4	24,5				
220			21,2	18,9			
240			18,5	16,5	13,3		
255			16,8	14,9	11,9	10,5	
260				14,4	11,5	10,0	
280				12,5	9,9	8,5	
295				11,2	8,9	7,5	
300					8,5	7,1	
320					7,0	5,8	
330					6,2	5,0	
340						4,3	
350						3,6	

Main boom 233 ft

Radius	Jib length in (ft)						
	135	144					
(ft)	lbs	lbs					
185,9	26,1						
190	25,4						
195	24,5	24,2					
200	23,6	23,3					
205	22,8	22,5					
210	22,0	21,7					
215	21,2	21,0					
220	20,5	20,3					
225	19,8	19,6					
230	19,1	18,9					
235	18,5	18,3					
240		17,7					
245		17,1					

Capacities in 1000 lbs with luffing jib (No. 2316.xx) 273,400 lbs counterweight + 125,700 lbs carbody counterweight. Above lift chart is for reference only. For actual lift duty and complete chart with all available configurations please refer to lift chart in operator's cab or manual.

Lift chart – luffing jib (No. 2316.xx)

Main boom angle 45°

Main boom 66 ft

Radius	Jib length in (ft)					
	66	105	164	203	243	282
(ft)	lbs	lbs	lbs	lbs	lbs	lbs
109,7	66,4					
115	73,9					
142		54,7				
155		46,2				
195			29,8			
210			24,9			
225				19,3		
250				14,9		
255					10,9	
285					8,6	
290						5,4
325						3,0

Main boom 134 ft

Radius	Jib length in (ft)					
	66	105	164	203	243	282
(ft)	lbs	lbs	lbs	lbs	lbs	lbs
158,4	40,5					
165	38,4					
195		29,4				
205		27,4				
240			19,2			
260			16,9			
275				13,6		
300				11,4		
305					9,1	
335					7,0	
340					6,6	4,0
370						2,1

Main boom 164 ft

Radius	Jib length in (ft)				
	66	105	164	203	243
(ft)	lbs	lbs	lbs	lbs	lbs
179,3	29,9				
185	28,8				
215		21,7			
225		20,2			
260			13,3		
280			11,6		
295				8,3	
320				6,4	
325					3,3
345					2,2

Main boom 194 ft

Radius	Jib length in (ft)			
	66	105	164	203
(ft)	lbs	lbs	lbs	lbs
200,2	21,5			
205	20,8			
235		15,1		
245		14,1		
285			7,2	
305			5,7	
315				2,3
320				2,0

Main boom 213 ft

Radius	Jib length in (ft)		
	66	105	164
(ft)	lbs	lbs	lbs
214,1	16,5		
220	15,9		
250		11,0	
260		10,1	
295			3,1
300			2,9
310			2,3
315			2,0

Main boom 233 ft

Radius	Jib length in (ft)	
	135	144
(ft)	lbs	lbs
284,5	2,0	

Capacities in 1000 lbs with luffing jib (No. 2316.xx) 273,400 lbs counterweight + 125,700 lbs carbody counterweight. Above lift chart is for reference only. For actual lift duty and complete chart with all available configurations please refer to lift chart in operator's cab or manual.

Working range - luffing jib (No. 1916.xx) **78° - 15°**

Main boom **88° - 45°**

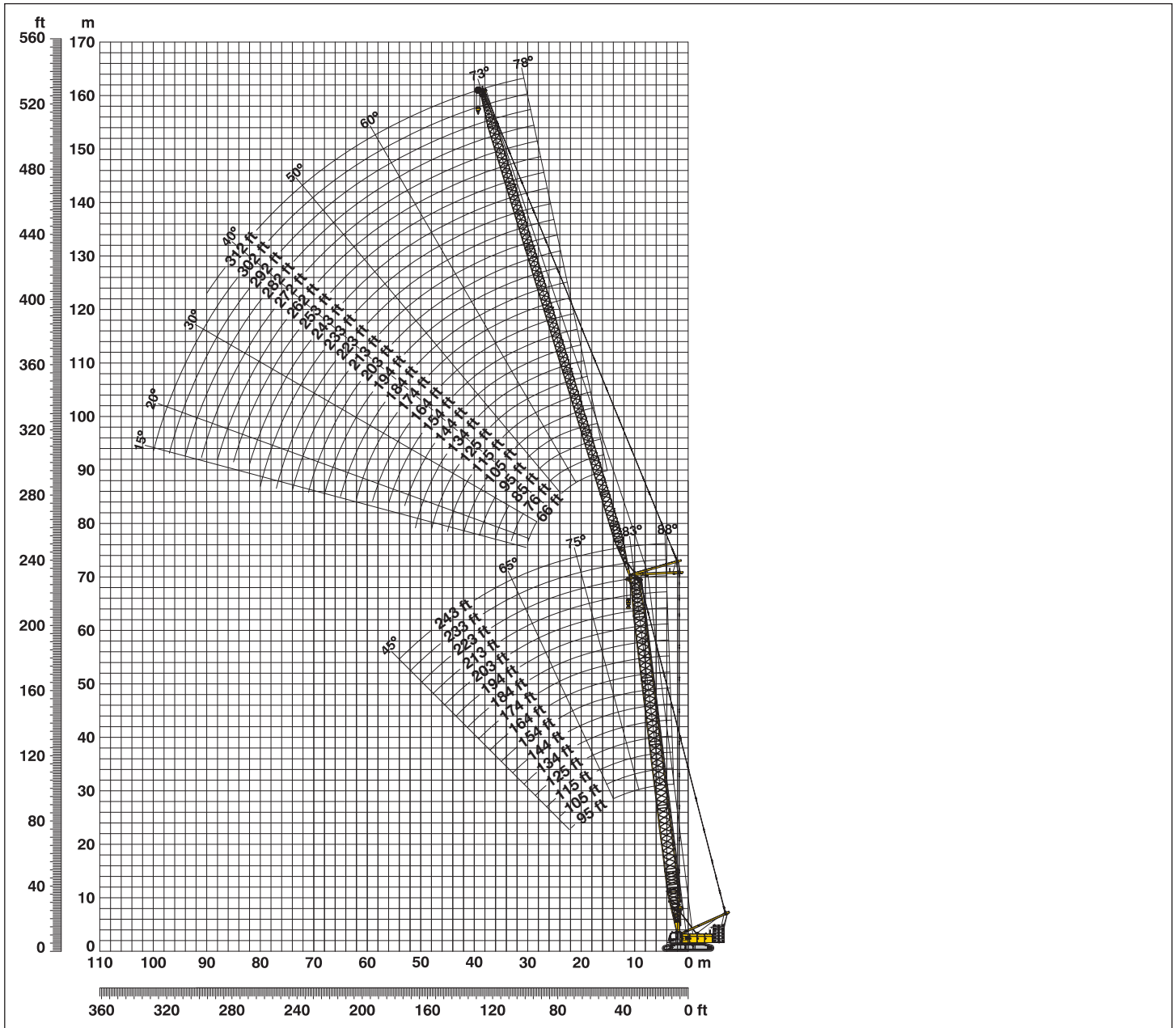

Boom configuration for main boom lengths (95 ft - 243 ft) – see table 1 on page 10
Jib configuration for jib lengths (66 ft - 312 ft)

	Length*	Amount of luffing jib extensions																									
		1	2	3	4	5	6	7	8	9	10	11	12	13	14	15	16	17	18	19	20	21	22	23	24		
Luffing jib foot	23 ft	1	1	1	1	1	1	1	1	1	1	1	1	1	1	1	1	1	1	1	1	1	1	1	1		
Luffing jib insert	10 ft		1		1		1		1		1		1		1		1		1		1		1		1		
Luffing jib insert	20 ft	1	1			1	1			1	1			1	1			1	1			1	1		1		
Luffing jib insert	40 ft			1	1	1	1	2	2	2	2	3	3	3	3	4	4	4	4	5	5	5	5	6	6	6	6
Luffing jib head	23 ft	1	1	1	1	1	1	1	1	1	1	1	1	1	1	1	1	1	1	1	1	1	1	1	1		
Luffing jib length (ft)		66	76	85	95	105	115	125	134	144	154	164	174	184	194	203	213	223	233	243	253	262	272	282	292	302	312

*Actual lengths of boom sections are metric (e.g. 3m, 6m, 7m, 12m). The figures shown above are approximate conversions to feet.

Lift chart - luffing jib (No. 1916.xx)

Main boom angle 88°

Main boom 95 ft

Radius	Jib length in (ft)							
	66	95	134	174	203	233	272	312
(ft)	lbs	lbs	lbs	lbs	lbs	lbs	lbs	lbs
41,7			103,7					
50		128,7	98,2	71,5				
60	128,5	114,4	89,4	68,6	53,1			
65	115,0	107,0	84,9	66,8	51,7	41,1		
70	99,6	100,9	80,5	65,1	50,7	40,1		
75	80,5	95,5	77,0	63,8	49,4	39,1	27,0	
80		88,4	73,2	62,3	48,4	38,3	26,4	17,6
105		33,4	55,6	55,2	43,7	34,6	23,8	15,8
140			38,0	43,2	39,3	30,5	20,7	13,5
180				26,9	30,2	26,5	18,0	11,5
205					22,1	24,1	16,9	10,5
235						16,6	15,8	9,2
240							15,3	9,0
275							11,2	7,7
300								6,5
310								6,0

Main boom 125 ft

Radius	Jib length in (ft)							
	66	95	134	174	203	233	272	312
(ft)	lbs	lbs	lbs	lbs	lbs	lbs	lbs	lbs
34,5		149,1						
40	175,3	143,9						
45	168,1	135,6	100,2					
55	145,9	120,4	92,1	68,8				
60	132,2	114,8	88,2	67,0	52,1			
65	118,9	107,5	84,6	65,5	50,7	39,9		
75	89,0	96,6	77,0	62,5	48,4	38,3	26,5	
100		65,5	59,7	56,4	43,7	34,7	23,8	15,9
105		57,7	56,7	54,8	42,9	34,0	23,4	15,5
140			39,2	44,0	38,6	30,2	20,3	13,4
180				28,0	30,5	26,5	17,8	11,4
210					21,7	23,4	16,5	10,2
235						17,3	15,6	9,1
275							11,4	7,7
300								6,7
315								5,6

Main boom 164 ft

Radius	Jib length in (ft)							
	66	95	134	174	203	233	272	312
(ft)	lbs	lbs	lbs	lbs	lbs	lbs	lbs	lbs
29,7	183,4							
40	164,1	136,7						
45	155,5	131,8	94,6					
55	140,7	119,7	89,3	65,9				
60	132,2	114,1	85,6	64,5	49,8			
65	120,7	108,0	82,9	63,4	49,2	38,2		
75	95,0	97,0	76,0	60,5	47,0	37,1	25,6	
85		85,2	69,8	58,1	45,1	35,6	24,9	16,6
105		60,8	57,3	53,8	41,8	33,1	22,8	15,4
120			49,4	50,8	39,8	31,4	21,5	14,3
145			27,4	42,2	37,2	29,0	19,6	12,8
180				29,0	30,8	26,2	17,5	11,2
210					22,1	23,8	16,2	10,0
240						13,3	15,2	8,8
275							11,7	7,6
315								5,8

Main boom 194 ft

Radius	Jib length in (ft)							
	66	95	134	174	203	233	272	312
(ft)	lbs	lbs	lbs	lbs	lbs	lbs	lbs	lbs
30,8	166,1							
40	148,9	128,5						
50	134,2	120,9	88,6					
55	128,1	116,0	86,0	62,9				
60	123,1	111,3	82,7	62,3	47,9			
70	114,0	101,0	77,1	59,6	46,6	36,8		
75	99,3	96,3	74,2	58,4	45,9	36,0	24,7	
80	33,4	91,7	71,9	57,5	44,8	35,2	24,6	
85		85,8	69,0	56,2	43,8	34,6	24,1	16,1
105		62,7	57,4	52,5	40,7	32,2	22,3	14,9
145			38,4	42,6	32,3	28,3	19,2	12,6
180				29,6	30,3	25,5	17,1	11,0
210					22,6	23,1	15,9	9,8
240						11,8	15,0	8,6
275							11,9	7,5
315								6,3

Main boom 223 ft

Radius	Jib length in (ft)							
	66	95	134	174	203	233	272	312
(ft)	lbs	lbs	lbs	lbs	lbs	lbs	lbs	lbs
31,8	147,7							
40	135,5	117,2						
50	122,0	111,4	82,7					
55	116,1	107,5	80,6	59,0				
65	107,4	99,9	75,8	57,5	45,7			
70	103,7	95,5	73,4	56,5	44,7	35,0		
75	96,0	91,9	70,7	55,4	43,9	34,6	23,8	
80	85,3	88,9	68,6	54,5	43,0	33,9	23,8	
85		84,4	66,4	52,0	42,1	33,4	23,4	15,5
105		64,2	56,2	43,1	37,3	31,1	21,6	14,7
145			38,8	35,3	29,9	26,5	18,7	12,3
185				18,3	29,2	22,2	16,5	10,5
210					23,0	20,4	15,6	9,6
240						17,1	14,6	8,4
280							8,9	7,2
315								6,1

Main boom 243 ft

Radius	Jib length in (ft)			
	66	95	134	174
(ft)	lbs	lbs	lbs	lbs
32,5	135,4			
40	126,9	108,8		
50	113,8	104,9	78,9	
60	103,9	97,3	75,1	56,5
70	96,4	90,2	71,0	54,6
80	85,5	84,0	66,6	52,6
90		77,5	62,0	47,4
100		70,4	57,2	42,6
110		29,2	53,1	40,4
120			48,6	39,1
130			45,1	38,1
140			41,1	36,5
150				35,0
160				33,8
180				29,3
185				14,7

Capacities in 1000 lbs with luffing jib (No. 1916.xx) 273,400 lbs counterweight + 125,700 lbs carbody counterweight. Above lift chart is for reference only. For actual lift duty and complete chart with all available configurations please refer to lift chart in operator's cab or manual.

Lift chart - luffing jib (No. 1916.xx)

Main boom angle 83°

Main boom 95 ft

Radius	Jib length in (ft)							
	66	95	134	174	203	233	272	312
(ft)	lbs	lbs	lbs	lbs	lbs	lbs	lbs	lbs
41,3	186,5							
50	173,7	142,3						
65	140,2	120,1	93,0					
75	114,2	106,3	84,6	66,2				
85	33,4	94,1	76,7	63,4	49,2			
95		81,4	68,2	60,6	47,0	37,3		
105		69,3	61,7	58,4	45,1	35,7	24,6	
110		61,9	58,6	56,5	44,2	35,1	24,2	
115			55,5	54,8	43,5	34,4	23,6	15,6
140			43,2	46,7	40,1	31,6	21,2	14,1
150			38,2	42,6	39,0	30,5	20,5	13,4
185				29,4	31,0	27,0	18,2	11,7
215					23,2	23,7	16,8	10,5
245						17,6	15,6	9,2
280							12,2	7,9
320								6,2

Main boom 125 ft

Radius	Jib length in (ft)							
	66	95	134	174	203	233	272	312
(ft)	lbs	lbs	lbs	lbs	lbs	lbs	lbs	lbs
44,9	183,6							
55	170,4	138,5						
65	149,4	123,4	90,5					
80	110,6	104,0	81,0	64,5				
85	95,5	99,2	77,2	62,9				
90		92,1	74,4	61,6	47,7			
95		85,6	70,1	60,3	46,6	36,5		
110		68,5	60,5	57,0	44,0	34,7	24,0	
115		61,5	57,4	55,5	43,2	34,2	23,5	
120			54,5	54,2	42,5	33,5	22,9	15,3
155			33,4	42,4	38,1	29,8	20,1	13,1
190				29,5	31,1	26,8	17,9	11,4
220					22,7	23,8	16,6	10,3
250						17,5	15,4	9,0
285							12,3	7,8
325								5,9

Main boom 164 ft

Radius	Jib length in (ft)							
	66	95	134	174	203	233	272	312
(ft)	lbs	lbs	lbs	lbs	lbs	lbs	lbs	lbs
49,7	177,7							
60	162,5	132,4						
70	144,5	120,6	87,7					
85	110,2	102,8	79,8	61,7				
90	95,8	98,2	76,5	60,5	46,1			
100		85,2	70,1	58,2	45,0	35,0		
115		68,8	60,7	55,3	42,6	33,5	23,2	
120		61,9	57,7	54,1	41,9	33,0	22,8	
125			54,9	53,0	41,3	32,3	22,2	14,9
160			32,8	42,2	37,2	29,0	19,6	12,8
195				29,8	30,9	26,3	17,5	11,1
225					19,0	23,7	16,2	10,1
255						16,2	15,2	8,8
290							12,3	7,7
300								7,4
330								6,0

Main boom 194 ft

Radius	Jib length in (ft)							
	66	95	134	174	203	233	272	312
(ft)	lbs	lbs	lbs	lbs	lbs	lbs	lbs	lbs
53,3	165,6							
65	148,7	124,3						
75	131,3	115,2	83,8					
85	116,4	105,1	79,4	59,5				
95	92,0	95,5	73,8	58,0	44,7			
105		83,1	67,8	56,0	43,5	33,7		
115		73,6	61,8	54,1	42,2	32,9	22,4	
125		33,2	56,5	52,4	40,7	31,9	22,0	
130			53,8	51,5	40,1	31,3	21,5	14,4
160			40,3	43,3	36,2	28,7	19,3	12,7
200				29,4	30,7	25,7	17,1	10,8
230					19,0	23,2	15,9	9,8
255						18,3	15,1	8,8
295							10,1	7,6
300								7,4
330								6,5

Main boom 223 ft

Radius	Jib length in (ft)							
	66	95	134	174	203	233	272	312
(ft)	lbs	lbs	lbs	lbs	lbs	lbs	lbs	lbs
56,9	147,1							
70	130,9	113,0						
80	116,3	105,9	78,1					
90	104,1	97,4	74,1	55,8				
100	33,4	89,4	69,3	54,5	42,3			
110		80,3	64,0	52,1	41,3	32,3		
120		71,2	58,9	50,0	39,7	31,4	21,5	
125		65,0	56,7	49,0	39,0	30,9	21,5	
130			54,1	47,7	38,3	30,5	21,1	13,9
165			39,5	39,7	34,4	27,4	18,6	12,2
205				17,8	29,4	24,5	16,6	10,5
230					23,6	22,9	15,7	9,6
260						18,0	14,8	8,5
300							9,7	7,3
320								6,8
335								6,4

Main boom 243 ft

Radius	Jib length in (ft)							
	66	95	134	174				
(ft)	lbs	lbs	lbs	lbs				
59,3	132,5							
70	120,1	106,2						
80	109,2	100,0	74,6					
95	94,9	89,1	69,9	53,6				
100	89,6	86,1	67,7	52,9				
110		79,0	63,5	50,6				
120		72,3	58,6	47,2				
130		61,4	54,4	44,7				
140			49,9	42,2				
150			46,2	40,3				
165			40,4	37,8				
170				37,1				
180				35,8				
190				33,5				
200				30,8				
205				29,4				

Capacities in 1000 lbs with luffing jib (No. 1916.xx) 273,400 lbs counterweight + 125,700 lbs carbody counterweight. Above lift chart is for reference only. For actual lift duty and complete chart with all available configurations please refer to lift chart in operator's cab or manual.

Lift chart - luffing jib (No. 1916.xx)

Main boom angle 75°

Main boom 95 ft

Radius	Jib length in (ft)							
	66	95	134	174	203	233	272	312
(ft)	lbs	lbs	lbs	lbs	lbs	lbs	lbs	lbs
63	167,7							
80	124,9	120,4						
95	98,4	99,8	81,1					
110		81,0	68,6	59,8				
125		63,8	59,0	57,1	44,2			
135			53,1	53,1	42,6	33,2		
155			44,0	46,1	40,0	31,3	21,1	
165			33,4	41,8	39,0	30,4	20,3	
170				40,0	37,7	29,9	19,9	13,0
200				30,9	31,8	27,0	18,1	11,7
230					24,9	23,7	16,8	10,4
260						18,9	15,7	9,2
280							14,2	8,5
295							13,3	8,0
300								7,8
335								6,0

Main boom 125 ft

Radius	Jib length in (ft)							
	66	95	134	174	203	233	272	312
(ft)	lbs	lbs	lbs	lbs	lbs	lbs	lbs	lbs
75	131,9							
85	113,3	112,5						
100	93,1	92,5	80,1					
105	87,7	87,3	78,3					
120		74,4	66,8	58,4				
130		67,6	61,0	56,4	43,0			
145			52,3	52,4	41,3	32,2		
160			45,8	48,3	39,5	30,9	20,2	
170			41,3	43,8	38,5	30,0	19,7	
175				41,9	37,9	29,6	19,4	12,7
210					31,0	30,9	26,7	17,4
235						25,6	24,5	16,4
265							19,6	15,5
305								13,3
320								7,3
340								6,5

Main boom 164 ft

Radius	Jib length in (ft)							
	66	95	134	174	203	233	272	312
(ft)	lbs	lbs	lbs	lbs	lbs	lbs	lbs	lbs
85	109,0							
95	95,4	94,4						
110	80,0	79,3	76,9					
115	75,7	75,2	74,0					
130		64,9	63,9	56,2				
140		59,4	58,4	54,7	41,2			
155			51,6	50,5	40,0	30,9		
170			46,1	45,1	38,4	29,8	19,8	
180			41,8	42,0	37,6	29,1	19,4	
185				40,5	37,2	28,7	19,1	12,2
220				30,0	30,9	26,3	17,2	10,9
245					25,3	24,5	16,3	10,0
275						19,4	15,4	8,9
315							12,7	7,8
340								7,0
350								6,7

Main boom 194 ft

Radius	Jib length in (ft)							
	66	95	134	174	203	233	272	312
(ft)	lbs	lbs	lbs	lbs	lbs	lbs	lbs	lbs
90	98,3							
105	81,7	80,7						
120	69,6	68,9	67,6					
135		59,8	58,7	54,1				
150		52,6	51,6	50,4	39,8			
160			47,7	46,5	39,0	29,8		
180			41,3	40,2	37,1	28,7	19,1	
190			32,3	37,5	36,4	28,1	18,8	
195				36,3	35,5	27,7	18,5	11,8
200				35,1	34,3	27,4	18,2	11,8
225				30,1	29,4	26,0	17,0	10,8
255					24,7	23,8	16,0	9,7
285						18,7	15,2	8,7
320							13,5	7,7
340								7,2
360								6,3

Main boom 223 ft

Radius	Jib length in (ft)							
	66	95	134	174	203	233	272	312
(ft)	lbs	lbs	lbs	lbs	lbs	lbs	lbs	lbs
100	83,2							
110	74,2	73,2						
130	60,6	59,9	58,6					
150		50,4	49,3	48,0				
155		48,4	47,4	46,0	37,9			
160		33,4	45,6	44,3	37,8			
170			42,3	41,0	37,1	28,5		
185			38,0	36,9	35,8	27,8	18,4	
195			35,6	34,5	33,6	27,3	18,2	
200				33,4	32,5	26,9	17,9	11,3
235				25,4	26,2	25,0	16,4	10,3
260					22,7	21,8	15,6	9,4
290						18,4	14,9	8,5
330							11,5	7,5
340								7,3
365								6,7

Main boom 243 ft

Radius	Jib length in (ft)							
	66	95	134	174				
(ft)	lbs	lbs	lbs	lbs				
105	76,0							
115	68,2	67,1						
135	56,1	55,4	54,1					
150		48,8	47,6	46,1				
155		46,9	45,7	44,3				
160		45,0	44,0	42,6				
165		33,4	42,3	41,0				
170			40,8	39,5				
180			38,0	36,7				
190			35,5	34,3				
200			33,2	32,1				
210				30,1				
220					28,3			
230					26,6			
235					25,8			
240					21,7			

Capacities in 1000 lbs with luffing jib (No. 1916.xx) 273,400 lbs counterweight + 125,700 lbs carbody counterweight. Above lift chart is for reference only. For actual lift duty and complete chart with all available configurations please refer to lift chart in operator's cab or manual.

Lift chart - luffing jib (No. 1916.xx)

Main boom angle 65°

Main boom 95 ft

Radius	Jib length in (ft)							
	66	95	134	174	203	233	272	312
(ft)	lbs	lbs	lbs	lbs	lbs	lbs	lbs	lbs
90	103,4							
110	81,2	80,6						
130		66,0	65,0					
140		60,3	59,4					
155			51,9	51,4				
170			45,7	45,9	39,0			
180			33,4	42,0	38,2			
185				40,2	37,7	29,1		
210				33,4	31,9	27,6	17,9	
215				32,5	31,6	27,0	17,7	
230					29,2	25,3	17,0	10,6
245					26,2	24,1	16,5	10,2
275						20,1	15,6	9,1
310							13,9	8,0
320								7,7
350								6,3

Main boom 125 ft

Radius	Jib length in (ft)							
	66	95	134	174	203	233	272	312
(ft)	lbs	lbs	lbs	lbs	lbs	lbs	lbs	lbs
101	86,0							
120	70,0	69,2						
125	66,5	65,9						
145		55,1	54,0					
155		33,4	49,8					
165			46,2	45,0				
180			41,5	40,3	37,8			
190			38,7	37,7	36,8			
200				35,3	34,5	28,1		
220				31,2	30,5	27,0	17,3	
230				29,4	28,7	26,3	17,1	
245					26,3	25,2	16,5	10,2
255					24,9	24,0	16,2	10,0
285						20,3	15,4	8,9
325							14,1	7,8
360								6,9

Main boom 164 ft

Radius	Jib length in (ft)							
	66	95	134	174	203	233	272	312
(ft)	lbs	lbs	lbs	lbs	lbs	lbs	lbs	lbs
117,3	66,4							
135	56,4	55,5						
140	53,9	53,1						
160		45,2	44,0					
170		41,9	40,8					
180			38,0	36,7				
200			33,3	32,1	31,2			
210			31,2	30,1	29,3			
215				29,2	28,4	26,8		
240				25,2	24,4	23,3	16,6	
245				24,4	23,7	22,6	16,5	
260					21,8	20,8	16,0	9,7
275					20,0	19,1	15,6	9,4
305						16,1	15,0	8,5
340							12,3	7,7
380								6,4

Main boom 194 ft

Radius	Jib length in (ft)							
	66	95	134	174	203	233	272	312
(ft)	lbs	lbs	lbs	lbs	lbs	lbs	lbs	lbs
129,8	55,3							
150	46,4	45,4						
155	33,4	43,6						
170		39,0	37,7					
180		36,2	35,0					
195			31,7	30,4				
210			28,8	27,5	26,6			
220			27,0	25,9	25,0			
230				24,3	23,5	22,3		
250				21,7	20,9	19,7	16,0	
260				20,4	19,7	18,6	15,9	
275					18,1	17,0	15,5	9,3
285					17,1	16,1	14,8	9,2
315						13,6	12,4	8,3
355							9,8	7,5
390								6,6

Main boom 223 ft

Radius	Jib length in (ft)							
	66	95	134	174	203	233	272	312
(ft)	lbs	lbs	lbs	lbs	lbs	lbs	lbs	lbs
142,2	45,5							
160	39,4	38,3						
165	37,8	36,9						
185		32,0	30,7					
195		29,9	28,7					
205			26,9	25,4				
225			23,7	22,4	21,5			
230			23,0	21,7	20,8			
240				20,5	19,6	18,4		
265				17,7	16,9	15,7	13,7	
270				17,2	16,4	15,2	13,3	
285					15,0	13,9	12,1	8,9
300					13,8	12,7	11,1	8,7
330						10,6	9,3	7,3
365							7,3	5,6
405								3,5

Main boom 243 ft

Radius	Jib length in (ft)							
	66	95	134	174				
(ft)	lbs	lbs	lbs	lbs				
150,6	39,7							
170	34,1	33,1						
175	32,9	31,9						
195		27,8	26,5					
205		26,0	24,8					
215			23,2	21,8				
220			22,5	21,1				
225			21,8	20,5				
230			21,2	19,8				
235			20,5	19,2				
240			19,9	18,6				
250				17,5				
260				16,5				
270				15,6				
275				15,1				
280				14,7				

Capacities in 1000 lbs with luffing jib (No. 1916.xx) 273,400 lbs counterweight + 125,700 lbs carbody counterweight. Above lift chart is for reference only. For actual lift duty and complete chart with all available configurations please refer to lift chart in operator's cab or manual.

Lift chart - luffing jib (No. 1916.xx)

Main boom angle 45°

Main boom 95 ft

Radius	Jib length in (ft)							
	66	95	134	174	203	233	272	312
(ft)	lbs	lbs	lbs	lbs	lbs	lbs	lbs	lbs
130,6	60,5							
140	55,6							
155		48,5						
170		33,4						
187			37,5					
205			33,4					
220				29,4				
245				25,4	24,6			
270					21,5	20,5		
300						17,4	14,6	
330							13,8	
335							13,4	7,6
340							13,0	7,5
360								7,2
375								7,1

Main boom 125 ft

Radius	Jib length in (ft)							
	66	95	134	174	203	233	272	312
(ft)	lbs	lbs	lbs	lbs	lbs	lbs	lbs	lbs
151,5	46,2							
160	43,2							
180		36,5						
190		33,4						
210			29,0					
225			26,4					
242				22,8				
265				20,0	19,2			
290					16,7	15,6		
295					16,3	15,3		
320						13,3		
325							11,7	
355							9,8	7,2
360							9,5	7,2
400								6,3

Main boom 164 ft

Radius	Jib length in (ft)							
	66	95	134	174	203	233	272	312
(ft)	lbs	lbs	lbs	lbs	lbs	lbs	lbs	lbs
179,3	32,0							
190	29,7							
205		26,0						
215		24,4						
240			19,8					
255			18,1					
268				15,6				
290				13,8				
294					12,6			
320					10,8	9,7		
350						8,0	6,5	
385							4,7	2,9
400								2,2

Main boom 194 ft

Radius	Jib length in (ft)							
	66	95	134	174	203	233	272	312
(ft)	lbs	lbs	lbs	lbs	lbs	lbs	lbs	lbs
200,2	23,6							
210	22,1							
225		19,1						
235		18,0						
260			14,3					
275			13,0					
290				10,6				
310				9,4				
315				9,1	8,2			
330					7,4			
340					6,8	5,1		
350						4,6		
370						3,6		

Main boom 223 ft

Radius	Jib length in (ft)				
	66	95	134	174	203
(ft)	lbs	lbs	lbs	lbs	lbs
221,1	16,4				
230	15,5				
246		13,0			
260		11,8			
280			9,1		
295			8,1		
310				5,2	
320				4,7	
335				4,0	2,7
340					2,5
350					2,1

Main boom 243 ft

Radius	Jib length in (ft)			
	66	95	134	
(ft)	lbs	lbs	lbs	
235	12,1			
240	11,7			
245	11,3			
260		8,7		
261		8,7		
265		8,4		
270		8,1		
295			4,7	
300			4,4	
305			4,2	
310			3,9	

Capacities in 1000 lbs with luffing jib (No. 1916.xx) 273,400 lbs counterweight + 125,700 lbs carbody counterweight. Above lift chart is for reference only. For actual lift duty and complete chart with all available configurations please refer to lift chart in operator's cab or manual.

Working range - fixed jib (No. 1713.xx) 15° and 30°

Main boom 88° - 30°

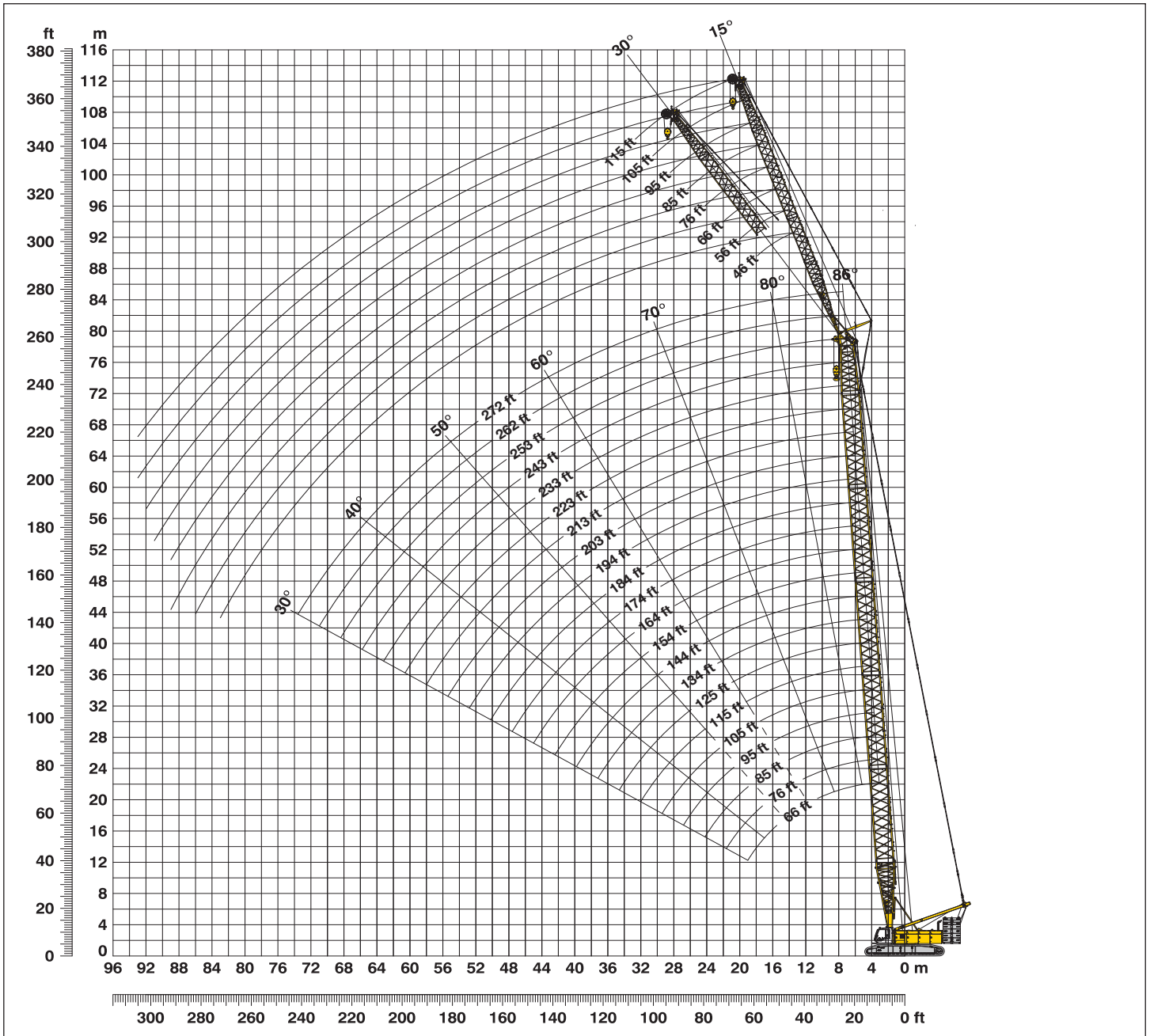

Boom configuration for boom lengths (66 ft - 272 ft) – see table 1 on page 10

Fixed jib configuration for fixed jib lengths (46 ft - 115 ft)

	Length*	Amount of fixed jib extensions							
Fixed jib foot	23 ft	1	1	1	1	1	1	1	1
Fixed jib insert	10 ft		1		1		1		1
Fixed jib insert	20 ft			1	1			1	1
Fixed jib insert	40 ft					1	1	1	1
Fixed jib head	23 ft	1	1	1	1	1	1	1	1
Fixed jib length (ft)		46	56	66	76	85	95	105	115

*Actual lengths of boom sections are metric (e.g. 3m, 6m, 7m, 12m). The figures shown above are approximate conversions to feet.

Lift chart - fixed jib (No. 1713.xx)

Offset 15°

Main boom 66 ft

Radius	Fixed jib length in (ft)			
	46	76	95	115
(ft)	lbs	lbs	lbs	lbs
45	97,3			
50	90,4	63,5	53,7	
55	85,9	59,7	50,7	44,6
60	80,3	56,5	47,0	41,6
80	63,4	44,5	36,9	33,1
100	53,5	36,4	30,3	27,7
110	48,9	33,3	28,6	25,0
120		31,4	26,3	22,9
140		27,6	22,8	19,6
155			20,8	17,8
160				17,2
175				15,7

Main boom 95 ft

Radius	Fixed jib length in (ft)			
	46	76	95	115
(ft)	lbs	lbs	lbs	lbs
40	121,3			
45	111,4	75,1		
50	104,0	70,4	58,6	48,5
60	90,2	61,4	51,4	42,4
80	73,1	50,0	40,9	33,9
100	61,2	41,5	34,1	28,8
120	54,2	35,7	29,4	24,5
135	48,9	32,9	26,9	22,0
140		32,7	26,0	21,4
165		28,7	22,6	18,2
185			20,6	16,5
200				15,4

Main boom 125 ft

Radius	Fixed jib length in (ft)			
	46	76	95	115
(ft)	lbs	lbs	lbs	lbs
35	129,6			
40	127,8	81,2		
45	118,5	75,9	62,7	
55	104,7	67,3	55,2	45,7
80	81,7	52,8	43,0	35,4
100	69,0	44,8	36,1	29,9
120	59,9	38,7	31,1	26,0
140	54,6	34,3	28,2	22,6
160	45,2	31,0	25,1	20,2
190		27,3	22,0	17,4
210			20,3	16,0
230				14,9

Main boom 154 ft

Radius	Fixed jib length in (ft)			
	46	76	95	115
(ft)	lbs	lbs	lbs	lbs
30	132,3			
40	127,5	83,2		
45	124,2	78,7	64,0	
55	110,0	70,4	57,0	46,7
80	86,8	57,1	45,1	37,0
120	65,7	42,5	33,9	28,6
140	54,2	38,0	30,4	25,4
160	44,0	34,2	28,2	22,6
185	34,5	31,7	25,0	20,0
215		27,6	22,4	17,6
220			22,0	17,3
255				15,4

Main boom 184 ft

Radius	Fixed jib length in (ft)			
	46	76	95	115
(ft)	lbs	lbs	lbs	lbs
27,9	132,3			
40	128,0	82,2		
50	120,9	74,0	59,6	
55	114,4	70,4	57,1	46,9
80	92,1	57,4	45,9	38,0
120	66,5	44,2	35,3	30,0
160	42,5	36,0	29,3	24,0
200	28,7	30,2	24,8	20,0
210	26,0	27,5	23,9	19,2
240		20,7	21,6	17,3
260			17,9	16,3
280				15,4

Main boom 203 ft

Radius	Fixed jib length in (ft)			
	46	76	95	115
(ft)	lbs	lbs	lbs	lbs
28,6	132,3			
40	128,8	82,3		
50	123,0	74,8	59,0	
55	117,0	71,1	56,7	47,1
80	95,4	58,4	46,3	38,7
120	65,5	45,9	36,0	30,9
160	41,5	37,4	29,5	25,0
200	27,6	29,1	25,3	20,9
230	20,4	21,8	22,7	18,6
255		16,9	17,8	17,2
275			14,5	15,2
295				12,3

Main boom 223 ft

Radius	Fixed jib length in (ft)			
	46	76	95	115
(ft)	lbs	lbs	lbs	lbs
29,3	132,3			
40	130,1	81,8		
50	122,9	75,1	59,7	
55	119,1	71,6	57,3	46,9
80	98,4	60,1	47,5	38,9
120	64,5	47,8	37,2	31,8
160	40,5	39,2	30,6	25,9
200	26,7	28,1	26,6	21,7
245	16,5	17,8	18,7	18,4
275		12,7	13,6	14,3
295			10,7	11,4
315				8,8

Main boom 253 ft

Radius	Fixed jib length in (ft)			
	46	76	95	115
(ft)	lbs	lbs	lbs	lbs
30,3	132,3			
45	126,3	78,4		
50	122,0	75,6	59,9	
60	114,4	69,8	55,7	44,5
80	99,6	61,5	48,7	38,9
120	63,1	49,3	38,7	32,5
160	39,0	40,4	32,3	26,7
200	25,2	26,7	27,7	22,5
270	10,8	12,0	12,9	13,6
300		7,8	8,7	9,3
320			6,0	6,8
340				4,0

Main boom 272 ft

Radius	Fixed jib length in (ft)			
	46	56	66	76
(ft)	lbs	lbs	lbs	lbs
31	125,2			
35	124,8	106,7		
40	124,6	104,7	92,5	
45	122,2	103,2	88,4	76,9
80	100,1	84,3	69,6	61,8
120	62,1	62,7	57,4	49,8
200	24,0	24,5	25,2	25,6
240	14,8	15,2	15,8	16,2
290	6,6	7,0	7,7	8,1
295		6,2	6,9	7,2
305			5,3	5,6
315				4,1

Capacities in 1000 lbs with fixed jib (No. 1713.xx) 273,400 lbs counterweight + 125,700 lbs carbody counterweight. Above lift chart is for reference only. For actual lift duty and complete chart with all available configurations please refer to lift chart in operator's cab or manual.

Lift chart - fixed jib (No. 1713.xx)

Offset 30 °

Main boom 66 ft

Radius	Fixed jib length in (ft)			
	46	76	95	115
(ft)	lbs	lbs	lbs	lbs
50	69,7			
60	63,7	43,8		
65	61,9	41,9	35,0	
75	57,1	38,5	32,8	27,7
80	55,3	36,8	31,7	27,3
90	51,5	34,1	29,4	25,1
100	49,1	32,1	27,0	23,1
110	47,5	31,0	25,2	21,3
120		29,2	23,5	19,9
140		27,4	21,1	17,4
160			19,9	15,7
180				14,8

Main boom 95 ft

Radius	Fixed jib length in (ft)			
	46	76	95	115
(ft)	lbs	lbs	lbs	lbs
45	80,6			
55	72,9	49,3		
65	66,8	45,0	36,7	
80	59,7	39,9	33,4	27,4
100	53,0	34,8	28,9	23,5
120	48,6	31,5	25,6	20,6
135	47,0	29,6	23,5	18,9
140		29,0	23,0	18,4
165		27,4	20,9	16,3
185			20,2	15,2
200				14,8
205				14,6

Main boom 125 ft

Radius	Fixed jib length in (ft)			
	46	76	95	115
(ft)	lbs	lbs	lbs	lbs
40	66,4			
55	75,7	48,8		
70	67,8	43,6	34,7	
80	63,5	40,4	32,3	28,1
100	56,6	35,8	28,7	24,5
120	51,9	32,4	25,6	21,8
140	48,6	30,3	23,3	19,7
160	45,5	28,3	21,6	17,9
180		27,3	20,2	16,6
190		26,9	19,9	16,0
210			19,4	15,2
230				14,8

Main boom 154 ft

Radius	Fixed jib length in (ft)			
	46	76	95	115
(ft)	lbs	lbs	lbs	lbs
37,5	66,4			
55	78,0	49,8		
70	70,6	44,8	35,6	
80	66,3	42,1	33,4	28,2
100	59,9	37,9	30,6	25,0
120	54,9	34,6	27,6	22,5
140	51,2	32,1	25,4	20,3
160	44,6	30,7	23,4	18,7
185	34,7	28,7	21,7	17,1
215		27,8	20,4	15,7
235			20,1	15,1
255				14,8

Main boom 184 ft

Radius	Fixed jib length in (ft)			
	46	76	95	115
(ft)	lbs	lbs	lbs	lbs
38,5	66,4			
60	76,6	47,3		
70	72,0	44,5	35,3	
80	68,6	42,3	33,3	27,3
120	58,1	35,2	27,8	22,3
160	43,3	30,6	23,8	19,1
180	35,3	29,0	22,4	17,7
200	29,0	27,7	21,2	16,7
215	24,9	26,9	20,5	16,1
240		21,0	19,9	15,2
260			18,2	14,9
280				14,6

Main boom 203 ft

Radius	Fixed jib length in (ft)			
	46	76	95	115
(ft)	lbs	lbs	lbs	lbs
39,2	66,4			
60	77,7	47,1		
70	73,3	44,6	35,4	
80	70,0	42,6	33,6	27,5
120	59,4	35,7	28,1	23,2
160	42,4	31,1	24,3	19,9
200	28,1	28,3	21,7	17,4
220	22,9	24,7	20,8	16,6
230	20,5	22,4	20,4	16,2
260		16,2	17,5	15,3
280			14,0	15,0
300				11,8

Main boom 223 ft

Radius	Fixed jib length in (ft)			
	46	76	95	115
(ft)	lbs	lbs	lbs	lbs
39,9	66,4			
60	78,1	47,1		
70	74,2	44,8	35,4	
85	69,6	41,9	33,0	27,3
120	61,5	36,3	29,2	23,4
160	41,6	31,9	25,5	20,1
200	27,3	29,1	22,6	17,8
220	22,1	23,9	21,7	16,9
245	16,7	18,4	19,7	16,0
275		12,9	14,2	15,1
295			11,0	12,0
315				9,1

Main boom 253 ft

Radius	Fixed jib length in (ft)			
	46	75	95	115
(ft)	lbs	lbs	lbs	lbs
40,9	66,4			
60	78,0	47,7		
70	74,8	45,6	35,6	
85	70,0	42,8	33,2	27,2
120	61,8	37,6	29,4	23,6
160	40,2	33,3	25,9	20,5
200	25,9	28,1	23,2	18,3
240	16,4	18,2	19,4	16,6
270	11,0	12,6	13,8	14,8
300		8,0	9,2	10,1
320			6,3	7,4
340				4,3

Main boom 272 ft

Radius	Fixed jib length in (ft)			
	46	56	66	76
(ft)	lbs	lbs	lbs	lbs
41,6	66,4			
50	82,1	68,1		
55	80,1	66,5	55,7	
60	78,1	65,1	54,4	47,3
80	71,8	59,8	50,1	43,3
160	39,2	40,1	38,3	33,4
200	24,9	25,6	26,5	27,1
240	15,4	15,9	16,7	17,2
290	6,8	7,4	8,2	8,6
300		5,6	6,4	7,0
310			4,7	5,3
320				3,6

Capacities in 1000 lbs with fixed jib (No. 1713.xx) 273,400 lbs counterweight + 125,700 lbs carbody counterweight. Above lift chart is for reference only. For actual lift duty and complete chart with all available configurations please refer to lift chart in operator's cab or manual.

Working range - fixed jib (No. 1008.xx) 15° and 30°

Main boom 88° - 30°

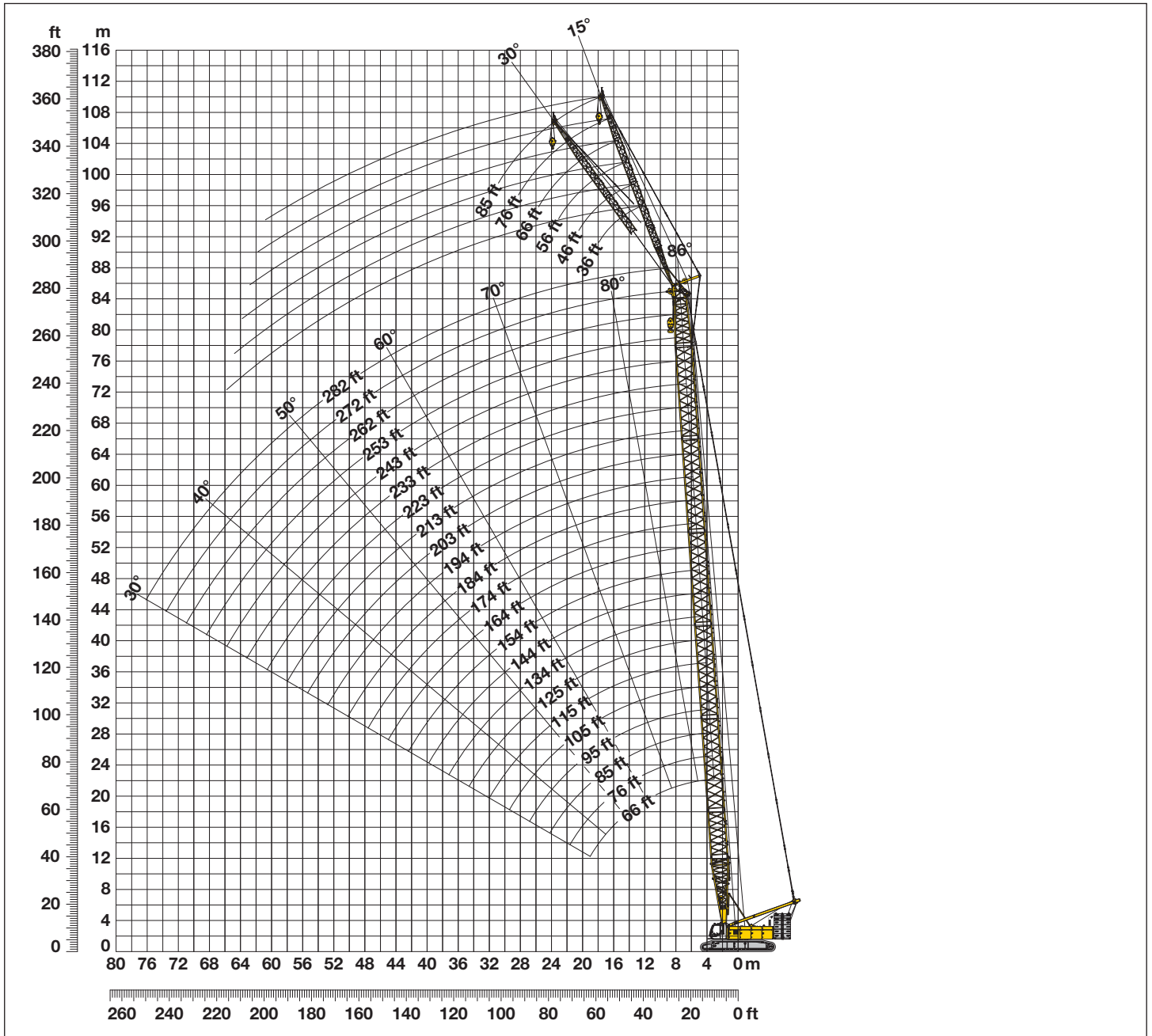

Boom configuration for boom lengths (66 ft - 282 ft) – see table 1 on page 10

Fixed jib configuration for fixed jib lengths (36 ft - 85 ft)

	Length*	Amount of fixed jib extensions					
		1	1	1	1	1	1
Fixed jib foot	18 ft	1	1	1	1	1	1
Fixed jib insert	10 ft*		1		1		1
Fixed jib insert	20 ft*			1	1	2	2
Fixed jib head	18 ft	1	1	1	1	1	1
Fixed jib length (ft)		36	46	56	66	76	85

*Actual lengths of boom sections are metric (e.g. 3m, 6m, 5.5m). The figures shown above are approximate conversions to feet.

Lift chart - fixed jib (No. 1008.xx)

Offset 15°

Main boom 66 ft

Radius	Fixed jib length in (ft)			
	36	46	66	85
(ft)	lbs	lbs	lbs	lbs
45	99,2	82,5		
55	89,2	76,7	57,6	
60	83,0	70,7	53,0	42,3
70	72,7	62,6	46,5	37,2
80	64,8	56,8	41,0	33,4
90	60,4	50,7	37,0	30,7
100	54,8	46,3	33,5	28,2
110		42,5	31,7	26,0
120			29,6	23,8
130			27,6	22,2
140				20,8
150				19,6

Main boom 95 ft

Radius	Fixed jib length in (ft)			
	36	46	66	85
(ft)	lbs	lbs	lbs	lbs
40	99,2	90,7		
45	99,2	87,7	70,2	
50	99,2	85,1	63,9	48,8
60	97,1	80,1	59,2	44,7
80	77,0	65,1	47,0	36,0
100	64,5	56,2	38,9	30,7
120	56,8	48,2	32,6	26,4
125	54,9	46,5	32,5	25,4
135		43,7	31,5	23,7
155			28,2	21,2
160				20,7
175				19,2

Main boom 125 ft

Radius	Fixed jib length in (ft)			
	36	46	66	85
(ft)	lbs	lbs	lbs	lbs
30	99,2			
35	99,2	93,9		
40	99,2	92,2	73,4	
45	99,2	88,8	69,9	51,1
80	87,2	71,4	49,9	38,5
100	73,2	60,2	42,1	33,4
120	62,3	52,2	36,6	29,2
140	55,6	46,4	32,6	26,1
150	50,1	44,1	32,3	24,6
160		42,0	30,9	23,3
180			28,3	21,3
200				19,7

Main boom 154 ft

Radius	Fixed jib length in (ft)			
	36	46	66	85
(ft)	lbs	lbs	lbs	lbs
30	99,2	96,5		
35	99,2	95,1	77,3	
45	99,2	92,1	72,3	50,9
80	97,5	78,3	54,6	40,3
100	81,4	67,5	46,7	34,4
120	67,8	61,1	40,5	31,4
140	54,3	53,6	36,1	28,1
160	44,2	45,0	33,0	25,4
175	38,2	39,0	32,3	23,6
185		35,5	31,1	22,6
205			28,8	21,0
225				19,7

Main boom 184 ft

Radius	Fixed jib length in (ft)			
	36	46	66	85
(ft)	lbs	lbs	lbs	lbs
23,2	99,2			
30	99,2	95,8		
35	99,2	94,7	75,3	
45	99,2	92,0	71,5	50,6
80	98,5	78,6	56,5	41,5
120	66,4	62,2	42,7	33,4
160	42,7	43,5	34,6	27,3
180	35,0	35,8	32,4	24,9
200	28,9	29,6	31,0	22,9
210		26,9	28,3	22,2
230			23,6	20,9
250				19,7

Main boom 203 ft

Radius	Fixed jib length in (ft)			
	36	46	66	85
(ft)	lbs	lbs	lbs	lbs
23,9	99,2			
30	99,2	95,6		
40	99,2	93,2	73,1	
45	99,2	92,1	71,7	50,4
80	98,3	80,2	57,7	42,3
120	65,5	60,9	44,7	33,4
160	41,7	42,5	36,3	28,3
200	27,8	28,5	29,9	24,0
220	22,8	23,5	24,8	22,4
230		21,3	22,6	21,8
245			19,6	20,7
265				17,1

Main boom 223 ft

Radius	Fixed jib length in (ft)			
	36	46	66	85
(ft)	lbs	lbs	lbs	lbs
24,6	99,2			
30	99,2	95,2		
40	99,2	93,3	72,5	
45	99,2	92,1	71,4	49,9
80	96,8	81,5	58,6	42,9
120	63,8	62,0	46,3	34,1
160	40,7	41,5	37,7	29,4
200	26,9	27,6	28,9	25,1
235	18,7	19,3	20,6	21,7
245		17,4	18,7	19,8
265			15,2	16,3
285				13,2

Main boom 272 ft

Radius	Fixed jib length in (ft)			
	36	46	66	85
(ft)	lbs	lbs	lbs	lbs
26,3	99,2			
35	99,2	93,2		
40	99,2	92,7	70,9	
50	99,2	91,4	69,0	48,2
80	99,2	85,1	60,4	43,3
120	62,0	63,0	49,3	35,6
160	38,0	38,9	40,0	31,5
200	24,2	24,9	26,4	26,9
280	8,6	9,2	10,4	11,4
285		8,5	9,7	10,7
305			7,0	8,1
325				5,3

Main boom 282 ft

Radius	Fixed jib length in (ft)		
	36	46	56
(ft)	lbs	lbs	lbs
26,7	99,2		
35	99,2	91,8	83,5
40	99,2	91,2	82,2
80	99,2	83,6	69,6
120	61,5	61,1	57,8
160	37,5	38,3	39,2
200	23,4	24,3	25,1
240	14,5	15,1	15,9
280	7,9	8,6	9,2
285	7,1	7,8	8,5
295		6,2	7,0
305			5,4

Capacities in 1000 lbs with fixed jib (No. 1008.xx) 273,400 lbs counterweight + 125,700 lbs carbody counterweight. Above lift chart is for reference only. For actual lift duty and complete chart with all available configurations please refer to lift chart in operator's cab or manual.

Lift chart - fixed jib (No. 1008.xx)

Offset 30°

Main boom 66 ft

Radius	Fixed jib length in (ft)			
	36	46	66	85
(ft)	lbs	lbs	lbs	lbs
50	66,5			
55	64,6	55,0		
65	58,4	49,1	34,9	
70	55,6	46,4	32,8	26,0
80	50,9	42,4	31,1	23,8
90	47,5	39,1	28,6	21,7
100	45,3	36,8	26,6	20,2
110		35,3	24,9	18,7
120			23,8	17,7
130			23,0	16,7
140				16,1
150				15,7

Main boom 95 ft

Radius	Fixed jib length in (ft)			
	36	46	66	85
(ft)	lbs	lbs	lbs	lbs
45	76,0			
50	72,3	63,7		
60	64,9	57,4	39,1	
65	64,3	54,4	37,2	27,8
80	57,0	48,0	32,9	26,2
100	50,0	41,9	30,2	22,6
120	45,9	37,8	27,0	19,9
125	45,2	37,2	26,3	19,4
135		36,2	25,1	18,5
155			24,0	17,0
160				16,8
175				16,4

Main boom 125 ft

Radius	Fixed jib length in (ft)			
	36	46	66	85
(ft)	lbs	lbs	lbs	lbs
40	83,4			
45	79,5	65,3		
55	72,4	61,1	41,0	
65	66,3	56,3	37,8	30,4
80	62,2	50,0	33,9	27,2
100	54,9	44,0	31,6	23,7
120	49,4	39,9	28,3	21,3
140	46,3	36,9	25,9	19,2
150	45,1	36,0	25,0	18,5
160		35,2	24,3	17,8
180			23,5	16,8
200				16,4

Main boom 154 ft

Radius	Fixed jib length in (ft)			
	36	46	66	85
(ft)	lbs	lbs	lbs	lbs
35	89,5			
40	85,3	70,2		
50	78,3	65,2	42,5	
65	69,9	59,2	39,2	30,6
100	57,5	47,8	32,0	24,7
120	52,4	43,2	29,8	22,2
140	48,4	39,9	27,4	20,3
160	44,7	37,5	25,5	18,8
175	38,5	36,6	24,4	17,9
185		35,8	24,0	17,4
205			23,4	16,7
225				16,4

Main boom 184 ft

Radius	Fixed jib length in (ft)			
	36	46	66	85
(ft)	lbs	lbs	lbs	lbs
32	92,8			
40	86,8	68,8		
55	77,4	62,4	41,7	
65	72,3	58,4	39,0	30,8
80	66,0	53,7	35,8	28,0
120	54,5	43,9	31,4	22,9
160	43,4	38,2	27,0	19,6
200	29,1	30,0	24,3	17,5
205	27,7	28,5	24,2	17,3
215		25,9	23,9	16,9
230			23,5	16,6
250				16,4

Main boom 203 ft

Radius	Fixed jib length in (ft)			
	36	46	66	85
(ft)	lbs	lbs	lbs	lbs
33,3	91,9			
40	87,7	69,2		
55	79,8	63,7	42,0	
65	74,9	60,4	39,7	31,0
80	69,6	55,5	36,8	28,5
120	58,2	46,8	31,1	23,9
160	41,5	40,6	27,2	20,7
200	27,4	28,2	24,6	18,5
235	18,9	19,7	21,2	17,1
245		17,6	19,1	16,8
265			15,4	16,6
285				13,4

Main boom 223 ft

Radius	Fixed jib length in (ft)			
	36	46	66	85
(ft)	lbs	lbs	lbs	lbs
33,3	91,9			
40	87,7	69,2		
55	79,8	63,7	42,0	
65	74,9	60,4	39,7	31,0
80	69,6	55,5	36,8	28,5
120	58,2	46,8	31,1	23,9
160	41,5	40,6	27,2	20,7
200	27,4	28,2	24,6	18,5
235	18,9	19,7	21,2	17,1
245		17,6	19,1	16,8
265			15,4	16,6
285				13,4

Main boom 272 ft

Radius	Fixed jib length in (ft)			
	36	46	66	85
(ft)	lbs	lbs	lbs	lbs
35	89,8			
45	85,1	68,4		
55	80,1	65,8	42,7	
70	74,4	63,0	39,7	29,6
120	62,3	50,8	32,8	24,5
160	39,1	40,3	30,5	21,5
200	24,9	25,8	27,5	19,3
240	15,5	16,3	17,9	17,6
280	8,8	9,4	10,9	12,2
290		8,0	9,4	10,7
310			6,4	7,9
330				4,9

Main boom 282 ft

Radius	Fixed jib length in (ft)		
	36	46	56
(ft)	lbs	lbs	lbs
35,4	89,7		
40	87,4		
45	85,3	66,5	
50	82,7	66,4	51,0
80	71,5	58,4	44,6
120	62,6	49,9	38,3
160	38,6	39,8	34,2
200	24,4	25,3	26,3
240	15,0	15,8	16,6
290	6,5	7,3	8,2
300		5,6	6,6
310			4,9

Capacities in 1000 lbs with fixed jib (No. 1008.xx) 273,400 lbs counterweight + 125,700 lbs carbody counterweight. Above lift chart is for reference only. For actual lift duty and complete chart with all available configurations please refer to lift chart in operator's cab or manual.

Notice

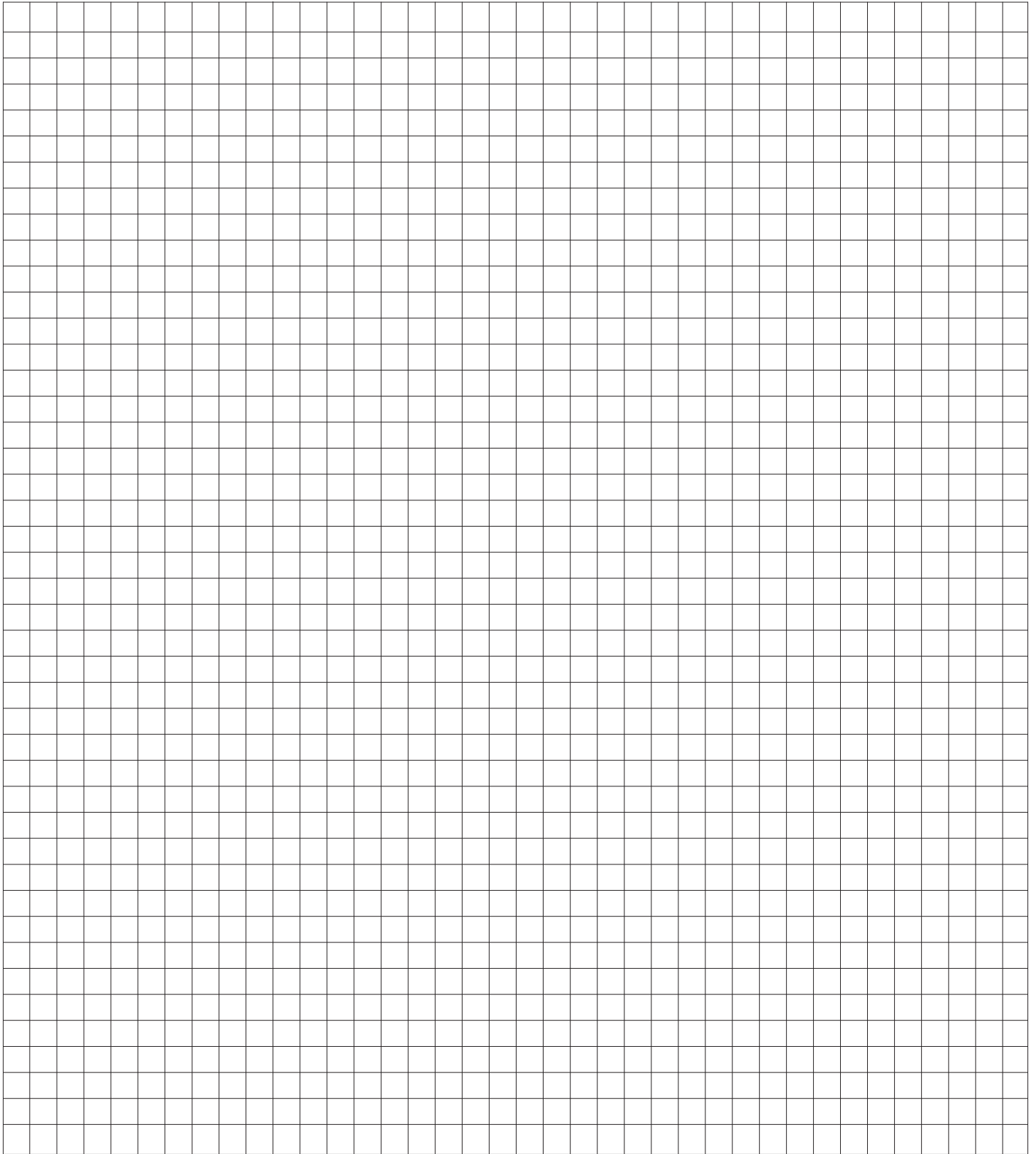

Notice

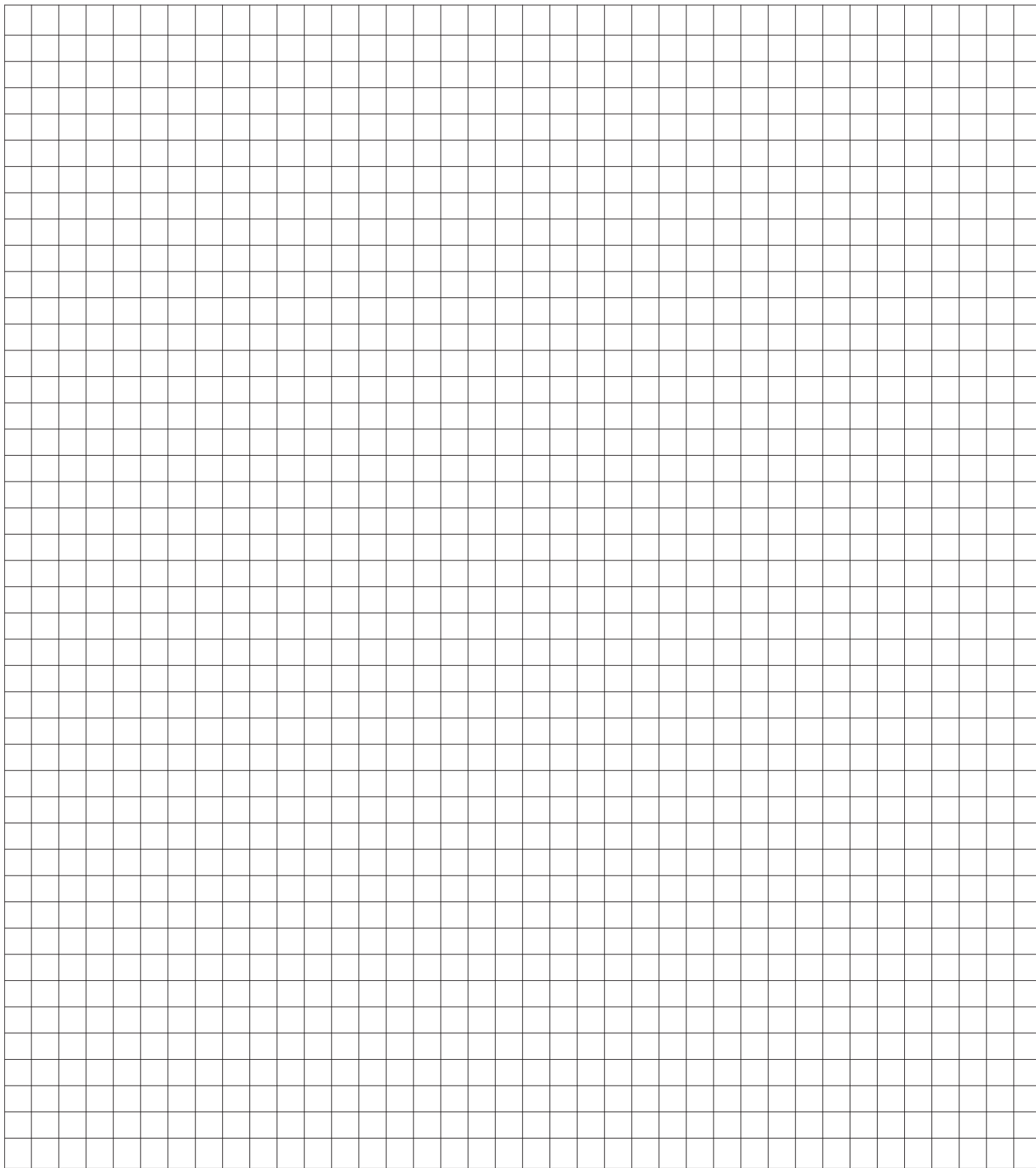

Liebherr-Werk Nenzing GmbH
P.O. Box 10, A-6710 Nenzing/Austria
Tel.: +43 50809 41-473
Fax: +43 50809 41-499
crawler.crane@liebherr.com
www.liebherr.com

Liebherr Nenzing Crane Co.
7075 Bennington Street, Houston, TX 77028-5812
Phone: +1 713 636 4050
Fax: +1 713 636 4051
crawler.crane@inc.liebherr.com
www.liebherr.com