R 9100

Generation 6

LIEBHERR

Mining excavator



Powertrain

Liebherr: 565 kW (FCO, Tier 4f)
757 HP

Backhoe configuration

Overall weight: 113 tonnes
125 tons
Bucket payload: 21 tonnes
23 tons

Face shovel configuration

Overall weight: 116 tonnes
128 tons
Bucket payload: 25 tonnes
27.5 tons

Overview
R 9100





Diesel drive 565 kW / 757 HP



BH 7.5 m³ / 9.8 yd³
FS 7.3 m³ / 9.6 yd³



BH 113 tonnes / 125 tons
FS 116 tonnes / 128 tons



Performance

Productive, efficient and reliable



V12
diesel engine





Efficient and effective by design, the R 9100 sets a new standard in job performance and functions as the optimal tool for loading 50 t up to 100 t off-highway trucks.

Fast and precise movement

Liebherr engine V12

The R 9100 is equipped with the long-lasting and proven Liebherr V12 diesel engine specifically designed to withstand extreme outside temperatures and high altitudes with low atmospheric pressure. The R 9100 is built for extreme conditions.

Fast cycle time

Like all other Liebherr mining excavators, the R 9100 uses a closed-loop swing circuit. The main hydraulic circuit comprises a combination of three independent main valves fed by three working pumps, providing unrivaled flexibility of attachment control and force distribution, while allowing full oil flow integration for fast movement and lowest cycle times.

Precise machine motions

The R 9100's hydraulic control system is optimized in order to improve combined machine motions. The ergonomically mounted joysticks on the suspended seat armrests allow the operator to precisely position the machine.

High digging and lifting capabilities

High digging forces & power-oriented energy management

Designed for the best mechanical force distribution, the production-tailored attachment delivers tough digging and lifting forces. Integrating Liebherr-made cylinders and a wide range of buckets with mining optimized GET, the R 9100's attachment ensures the highest forces, easy bucket penetration and high fill factor to perform even in the most demanding conditions.

Liebherr diesel engine

- V12 by Liebherr
- FCO, US EPA Tier 4f / EU Stage V compliant
- Automatic idle control
- Max. altitude without derating: 3,600 m
- Eco-Mode selector

Exclusive EVO bucket solution

- Liebherr patented EVO design to maximize the loading capacity
- Optimized Liebherr GET and wear package according to customer application (GP, HD, XHD)
- Ensures optimal penetration efficiency
- Single GET hammerless locking system for safe and easy maintenance
- Fully patented GET system design for optimal penetration / lifetime
- 4 tooth profiles available for various range of applications

The R 9100 follows the Liebherr design philosophy of maximizing a machine's performance by improving the efficiency of all individual subsystems. Engineered for excellent serviceability, the machine is designed to ensure maximum uptime. The R 9100's modern cab creates a comfortable working environment, ensuring peak operator performance at every shift.

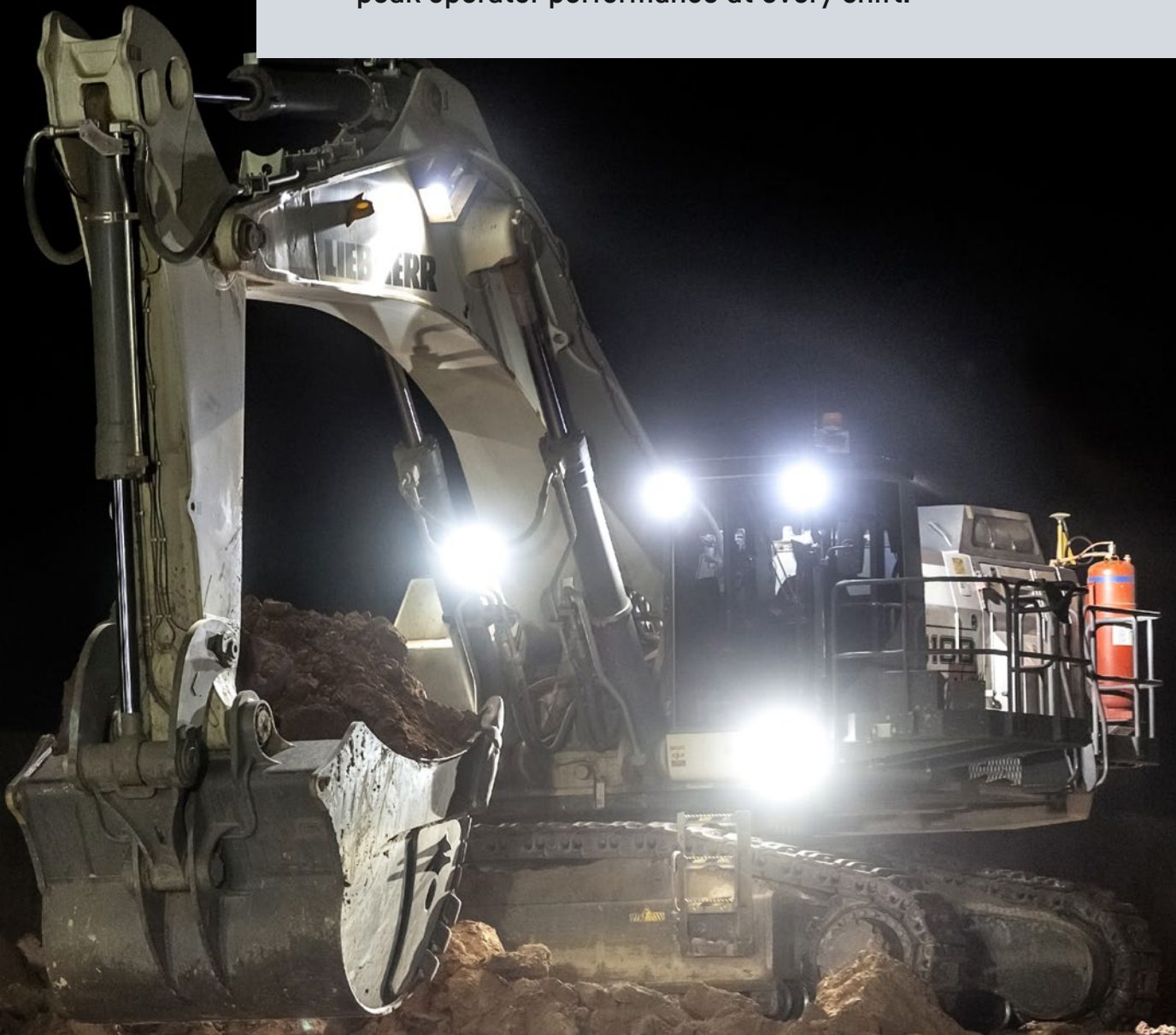

Built for maximum profitability

Hydraulic system efficiency

Liebherr advanced hydraulic technology contributes to the R 9100's energy optimization. The high-pressure hydraulic system and the optimized pipe and hose layout maximize usable power transmission. The hydraulic pumps are managed to provide optimal pressure compensation and oil flow management. The hydraulic system is independently regulated over the engine circuit for the best operational efficiency.

Closed loop swing circuit

The Liebherr mining excavators are all equipped with a closed loop swing circuit. The kinematic energy is recovered when the swing motion is used during deceleration, to drive the main and auxiliary pumps, reducing fuel consumption.

Independent cooling system

Oil and water cooling fans are independent and electronically managed. The on-demand cooling control enables to maximize available power for the working process. This technology contributes to maintain sustainable temperature of all the hydraulic components extending their life while reducing the fuel consumption.

Comfortable cab for efficient work

The modern cab which equips the R 9100 offers ideal working conditions and optimal operator's comfort. Mounted on silent blocks, the cab design reduces vibrations and limit noise pollution to provide a quiet environment.

Extended components lifetime

The R 9100's hydraulic oil filtration systems remove fluid contaminants to offer the highest rate of hydraulic components durability. To maintain oil quality, all return hydraulic oil flow goes through a fine filtration system (15/5 µm) and oil tank is sized to considerably extend the time between service intervals.



Advanced machine monitoring

- 10.5" LCD color screen
- Information interface to operator
- On-board diagnostics to service staff
- Real text information
- Long term data storage for maintenance



First-class service arrangements

- Service friendly design allows easy and fast maintenance for maximum uptime:
- Service from one-side
 - Large catwalks and walkways
 - Refillable grease tanks instead of drums to be changed
 - Centralized single-line lubrication system with bucket included



Comfort-oriented cab design

- Tinted laminated safety glass
- Armored front window
- Adjustable air suspended seat
- A/C with dust filter in fresh air / recirculated
- Pressurization to prevent dust penetration (optional)
- Optional Operator Comfort Kit: sun blinds, bottle cooler, reading light, premium seat with cooling / airing system, electronic weight adjustment
- Pre-heating system (optional)



Quality
The Liebherr trademark

With over 50 years of innovative thinking, engineering and manufacturing excellence, Liebherr sets the industry standard for advanced equipment design and technology tools to provide the most up-to-date product, responding to the requirements of mining customers.

Long-lasting job performances

Maximized components lifetime

The R 9100 is equipped with an automatic single line lubrication system for the entire attachment and swing ring. All greasing points are suitably protected against external damages, extending component life and ensuring constant performance over the excavator's operational life.

Liebherr components integration

As an OEM, Liebherr has built a solid reputation for its development and production of high quality strategic mining components. The R 9100 integrates robust and reliable mining optimized components that are developed, manufactured and controlled by Liebherr, ensuring reliability and high performance for the entire machine.

Structure made exclusively for mining

Liebherr mining excavators are conceptualised, designed and dedicated to the mining industry. The engineering department uses specific 3D solution in order to meet possible requirements, such as Finite Element and Fatigue Life Analysis. In combination, the manufacturing department uses advanced welding techniques to strategically reinforce the structure. The synergy of our skills allows to obtain maximal machine availability.

Reinforced undercarriage structure

Specifically designed for extreme mining conditions, the rugged R 9100 undercarriage represents the basis for the stability of the machine. Developed and built for both shovel and backhoe configurations, the enlarged undercarriage offers an efficient ground bearing pressure management providing the necessary stability and reliability. The access to the travel motors and brakes has been designed to provide maximum protection to the components, while providing easy and fast service access.



Liebherr vertical component integration

- Diesel engine
- Hydraulic pumps and motors
- Electronic and control technology
- Swing and travel drives
- Hydraulic cylinders
- Splitter box
- Swing ring
- GET



Quality commitment

- Liebherr-Mining Equipment Colmar, France, ISO 9001 certified
- Compliance of materials tested in laboratory
- Quality control during the stages of production
- CE certified (2006/42/EC), MDG 15 and MDG 41 compliant



Arctic package (optional)

Designed for reliability in regions with temperatures of down to -50 °C / -58 °F:

- Integrated into machine structure
- Start up easily even at very low temperatures
- Increases machine availability and components lifetime
- Optimum operator comfort even in harsh temperature conditions
- Facilitate machine servicing

Service

Where you need it, when you need it

By partnering with our customers, Liebherr implements tailored solutions from technical support, spare parts and logistics solutions to global maintenance for all types of equipment, all over the world.



Troubleshoot advisor platform

- Unique maintenance system to help you identify problems
- Easy and friendly-user interface
- Compatible with mobile, tablet or laptop
- Regular updating of the database
- Procedures described by specialist with images and videos



MyLiebherr customer portal

- Easy access parts online
- Available any time anywhere
- User friendly interface
- Online ordering
- Save time and money

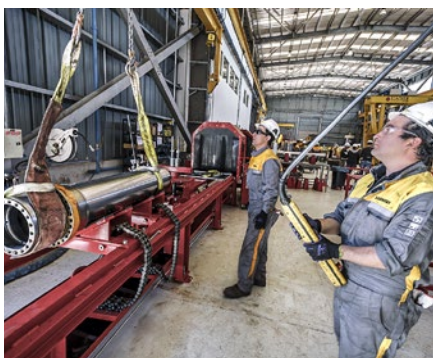

The Liebherr-Mining remanufacturing program

- Liebherr certified quality
- As-new warranty
- OEM expertise
- Reduced costs and investment
- Fast availability



Customer support

International service organization

The Liebherr service support has always been an important focus for the company. Complete service during all operating phases from machinery installation to problem solving, spare parts inventory and technical service. Our service team is close to our customers, delivering the best specific maintenance solution to reduce both equipment downtime and repair costs.

Complete training programs

The Liebherr mining training system provides blended training sessions for operator and maintenance staff to encourage productive, cost-effective and safe mining operation. The Liebherr mining training system employs online learning programs, factory and on-site sessions and simulator training.

Remanufacturing

Reduced costs and investment

Over the course of a mining machine's lifetime, major components must be replaced to ensure continued safety, productivity and reliability. The Liebherr mining remanufacturing program offers customers an OEM alternative to purchasing brand new replacement components. Enabling customers to achieve lowest possible equipment lifecycle costs without compromising quality, performance or reliability.

Fast availability

A international service network and component facilities worldwide means that component repair services and exchange components are available to customers regardless of their location.

Genuine parts

Performance

Using genuine Liebherr components ensures the best interaction within your machine, encouraging optimal performance and most effective machine operation. For all major components, Liebherr relies on its Liebherr maintenance management system to follow and monitor service life while predicting maintenance activities.

Partnership

Liebherr regularly reviews requirements for parts and components for individual machines, based on operating hours, consumption and planned maintenance, resulting in minimized down time for customers. With access to the global stock via all Liebherr mining warehouses, you will improve productivity by having the part you need, when you need it.

Safety

Protecting your most important assets

The Liebherr R 9100 provides uncompromising safety for operators and maintenance crew. As it is designed to be serviced from one side, the R 9100 allows effortless access facilities to the major service points for quick and safe maintenance. The R 9100 offers numerous features for operator safety.



Safety-first working conditions

Safe service access

The R 9100 is fitted with ergonomic access for fast and safe maintenance. All service points are within reach from one side and at machine level. The R 9100's upperstructure is accessible via a robust fixed ladder and integrates one large central platform equipped with slip resistant surfaces. The wide catwalks facilitate maintenance and ensure comfort during all the operations.

Secure maintenance

All components have been located to allow for effortless inspection and replacement. Numerous service lights are perfectly located in the service areas to guaranty suitable maintenance conditions, day or night. Emergency stops have been strategically placed in the cab and engine compartment (at ground level in option). The R 9100 eliminates hazards to ensure a safe environment for the service staff during maintenance.

Efficient machine protection

Protection against fire ignition

The engine compartment integrates a bulkhead wall that separates the engine from the hydraulic pumps. This reduces the risk of hydraulic oil entering the engine compartment. The turbochargers and exhaust systems are heat shielded, and all the hydraulic hoses are made from a fire resistant material.

Automatic fire suppression system

The R 9100 can be equipped with a fully integrated fire suppression, employing a dual agent solution to prevent and protect the machine. The fire suppression system has both automatic and manual release capabilities. E-stops, interconnected with the fire suppression system, are strategically located in the cab, over the machine, on the ground level to be easily accessible in any case by the operator or maintenance. The automatic fire suppression system is connected to the machine electronic, in case of release, the 45° access stairway is automatically activated.



Working environment control

- Rear and side camera system
- LCD color screen to display cameras view
- 9 long-range working LED lights located on attachment and upper-structure



User friendly maintenance

- Wide walkways with slip-resistant surfaces
- Emergency ladder available outside the cab
- Wide open service access
- Reflective stripes on counterweight
- 45° hydraulic driven access stair (optional)



Commitment to employees safety

- Safe and protected access to the components
- Major components centralized to be easily accessible
- Optional ground-level fluid maintenance hub
- E-stops located for the operator and maintenance staff
- FOPS: Falling Object Protective Structure (optional)

Sustainability

Committed to our future



Eco-Mode

Eco-Mode

The Eco-Mode can be manually selected by the operator when maximal power is not required according to job need for:

- An improved fuel efficiency
- Less load on the engine
- Less noise pollution
- Less dioxide carbon emissions

The Liebherr-Mining remanufacturing program

- Reduced environmental impact
- Second life for your components
- Reduced costs and investment
- Liebherr certified workshops
- Alternative to purchase brand-new replacement components

Automatic idle control

Electronic idle control of the engine results in:

- Less fuel consumption
- Less load on the engine
- Reduced emissions
- More comfort to the operator (reduced noise pollution)



Liebherr considers the conservation and preservation of the environment as a major challenge for the present and future. Liebherr are considerate of environmental issues in designing, manufacturing and managing machine structures, providing solutions that allow customers to balance performance with environmental consciousness.

Minimized impact on life

Optimized energy consumption, fewer emissions

Constant power regulation of the hydraulic system and engine output optimize equipment fuel efficiency, depending on the application. In “Eco-Mode” setting, the machine is set up to reduce engine load, significantly improve fuel consumption and reduce emissions.

Controlled emission rejection

The R 9100 can be offered with a diesel engine which complies with US EPA Tier 4f / EU Stage V emission limits. This power drive makes the R 9100 cost effective without compromising productivity and reduces the machines impact on the environment.

Sustainable design and manufacturing process

Certified environment management systems

Subject to the stringent European program for the regulation of the use of chemical substances in the manufacturing process REACH*, Liebherr undertakes a global evaluation to minimize the impacts of hazardous material, pollution control, water conservation, energy and environmental campaigns.

Extended components and fluids lifetime

Liebherr is constantly working on ways to extend component life. Through the Liebherr-Mining remanufacturing program, superior lubrication systems and the reinforcement of parts under stress, Liebherr can reduce frequency of part replacement. The result minimizes environmental impact and lowers the overall total cost of ownership.

*REACH is the European Community Regulation on chemicals and their safe use (EC 1907 / 2006) It deals with the registration, evaluation, authorization and restriction of chemical substances.

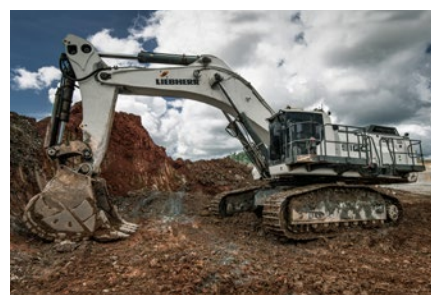

The four pillars of the Liebherr mining division

With more than 50 years of experience in the mining industry, Liebherr has identified four key factors of customer satisfaction: Performance, Safety, Service, and Sustainability. These pillars provide structure and focus for all our activities, and embody Liebherr's customer commitments.





Performance
Productive, efficient and reliable



Safety
Protecting your most important assets



Service
Where you need it, when you need it



Sustainability
Committed to our future



Technical data

Powertrain

1 Liebherr diesel engine	
Rating per ISO 9249	565 kW (757 HP) at 1,800 rpm
Model	Liebherr D9512 (US EPA Tier 4f / EU Stage V compliant or fuel consumption optimized setting)
Type	V12 cylinder engine
Bore / Stroke	128 / 157 mm / 5.04 / 6.18 in
Displacement	24.24 l / 1,479 in ³
Engine operation	4-stroke diesel common-rail direct injection turbo-charged
Cooling	water-cooled, hydrostatic fan drive
Air cleaner	dry-type air cleaner with pre-cleaner, primary and safety elements, automatic dust discharge
Fuel tank capacity	1,478 l / 390 gal (2,580 l / 682 gal optional)
Engine idling	electronically controlled
Electrical system	
Voltage	24 V
Batteries	4 x 75 Ah / 12 V
Starter	24 V / 2 x 8.4 kW
Alternator	24 V / 140 A
RPM adjustment	brushless adjustment of engine output via rpm selector

Hydraulic controls

Power distribution	via monoblock control valves with integrated primary and secondary relief valves
Flow summation	to attachment and travel drive
Closed-loop circuit	for uppercarriage swing drive
Servo circuit	
Attachment and swing	proportional via hydraulic joystick levers
Travel	proportional via hydraulic pedals or removable hand levers
Shovel flap functions	proportional via hydraulic pedals

Swing drive

Hydraulic motor	2 Liebherr axial piston motors
Swing gear	2 Liebherr planetary reduction gears
Swing ring	Liebherr, sealed single race ball bearing swing ring, internal teeth
Swing speed	0 - 6.0 rpm
Swing-holding brake	wet multi-disc brakes, spring applied, hydraulically released

Hydraulic system

Hydraulic pump	
for attachment and travel drive	3 Liebherr variable flow axial piston pumps
Max. flow	3 x 435 l/min. / 3 x 115 gpm
Max. pressure	350 bar / 5,076 psi
for swing drive	1 Liebherr reversible swashplate pump, closed-loop circuit
Max. flow	420 l/min. / 111 gpm
Max. pressure	350 bar / 5,076 psi
Pump management	electronically controlled pressure and flow management with oil flow optimisation
Hydraulic tank capacity	1,000 l / 264 gal
Hydraulic system capacity	1,500 l / 396 gal
Hydraulic oil filter	1 high pressure safety filter after each high pressure pump + extra-fine filtration of entire return flow with integrated by-pass filtration (15/5 µm) + dedicated leak-oil filtration
Hydraulic oil cooler	1 separated cooler, temperature controlled fan driven via 1 hydraulic piston motor
MODE selection	adjustment of machine performance and the hydraulics via a mode selector to match application
ECO	for economical operation (can be combined with fuel optimized setting)
POWER	for maximum digging power and heavy duty jobs

Electric system

Electric isolation	easy accessible battery isolators
Working lights	high brightness LED lights: - 2 on working attachment - 2 on cabin - 2 on RHS of uppercarriage - 3 on LHS of uppercarriage
Emergency stop switches	in the cab / in engine compartment
Electrical wiring	heavy duty execution in IP 65 standard for operating conditions of -50 °C to 100 °C / -58 °F to 212 °F

Uppercarriage

Design	torque resistant modular design upper frame
Attachment mounting	parallel length girders
Catwalks	large catwalk on the left-hand side

Cab

Design	sound insulated, tinted windows, front window armored glass, door with sliding window
Operator's seat	air suspended, body-contoured with shock absorber, adjustable to operator's weight
Joysticks	joystick levers integrated into armrest of seat, armrest adjusted to seat position
Condition monitoring	machine condition monitoring system with error reporting and operational information
Display	color LCD-display with low and high brightness settings, 1 additional fixation for supplementary customer device
Vision system	camera installation on counterweight and right-hand side of the uppercarriage, displayed over the LCD-display
Heating system / Air conditioning	standard automatic air conditioning, contains fluorinated greenhouse gases HFC 134a with a Global Warming Potential (GWP) of 1430, the AC circuit contains 1.7 kg / 3.8 lb of HFC-134 representing an equivalent of 2.4 tonnes / 2.7 tons of CO ₂ , combined cooler / heater, additional dust filter in fresh air / recirculated
Noise level (ISO 6396)	L _{pa} (inside cab) = 76 dB(A)
Hand-arm vibrations	≤ 2.5 m/s ²
Whole-body vibrations	≤ 0.5 m/s ²

Undercarriage

Version HD	heavy duty
Drive	Liebherr swashplate motors
Travel gear	Liebherr planetary reduction gears
Travel speed	0 - 3.5 km/h / 0 - 2.17 mph
Track components	track pitch 280 mm / 11.02 in, maintenance-free
Track rollers / Carrier rollers	8 / 2 per side frame
Track pads	double grouser
Track tensioner	spring with grease tensioner
Parking brake	wet multi-discs (spring applied, pressure released)
Brake valves	integrated in main valve block

Central lubrication system

Type	single line lubrication system, for the entire attachment / swing ring bearing and teeth
Grease pumps	1 hydraulic pump for attachment / swing ring bearing lubrication, 1 electric pump for swing teeth lubrication
Capacity	27 l / 7.1 gal bulk container for attachment / swing ring bearing, separated 8 l / 2.1 gal container for swing ring teeth
Refill	via quick connections and grease filters for both containers

Attachment

Design	box-type, combination of resistant steel plates and cast steel components
Hydraulic cylinders	Liebherr design
Hydraulic connections	pipes and hoses equipped with SAE flange connections
Pivots	sealed, low maintenance
Pivots bucket-to-stick Pivots bucket-to-link	O-ring sealed and completely enclosed

Dimensions

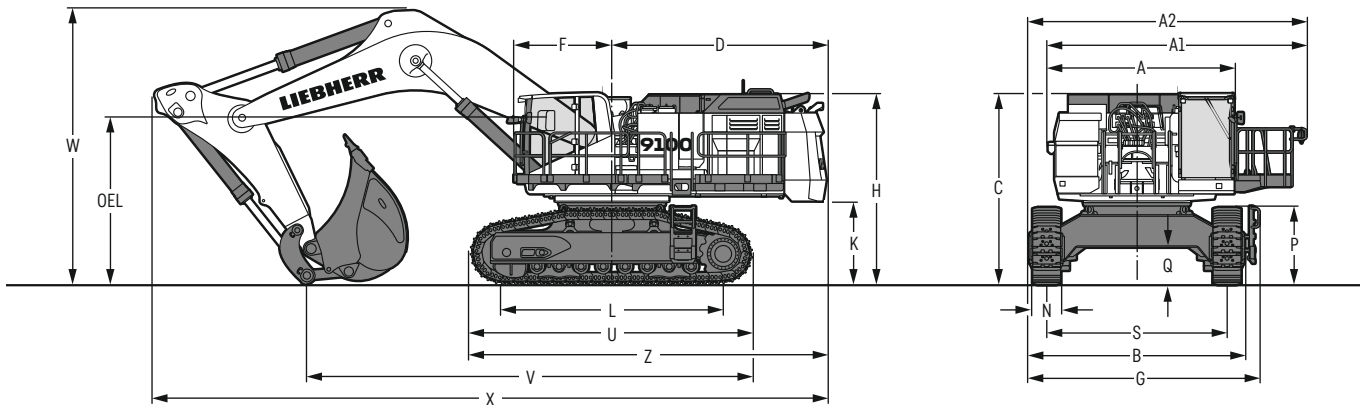

	mm / ft in
A	4,059 / 13'3"
A1	5,443 / 17'9"
A2	5,856 / 19'2"
B	4,685 / 15'4"
C	4,143 / 13'6"
D	4,630 / 15'2"
F	2,107 / 6'9"
G	4,995 / 16'4"
H	4,114 / 13'5"

	mm / ft in
K	1,803 / 5'9"
L	4,810 / 15'8"
N	500 / 1'6"
	600 / 2'
	750 / 2'5"
P	1,663 / 5'5"
Q	812 / 2'7"
S	3,900 / 12'8"
U	6,107 / 20'
Z	7,683 / 25'2"
OEL (Operator's eye level)	3,533 / 11'6"

	Stick length m / ft in	Mono boom 7.60 m / 24'9" mm / ft in	Mono boom 9.20 m / 30'2" mm / ft in
V	3.20 / 10'5"	9,660 / 31'7"	11,445 / 37'6"
	4.50 / 14'8"	- / -	9,930 / 32'6"
	5.60 / 18'4"	- / -	9,890 / 32'5"
W	3.20 / 10'5"	6,035 / 19'8"	6,210 / 20'4"
	4.50 / 14'8"	- / -	6,800 / 22'3"
	5.60 / 18'4"	- / -	7,550 / 24'8"
X	3.20 / 10'5"	14,560 / 47'8"	16,080 / 52'8"
	4.50 / 14'8"	- / -	15,385 / 50'5"
	5.60 / 18'4"	- / -	14,825 / 48'6"

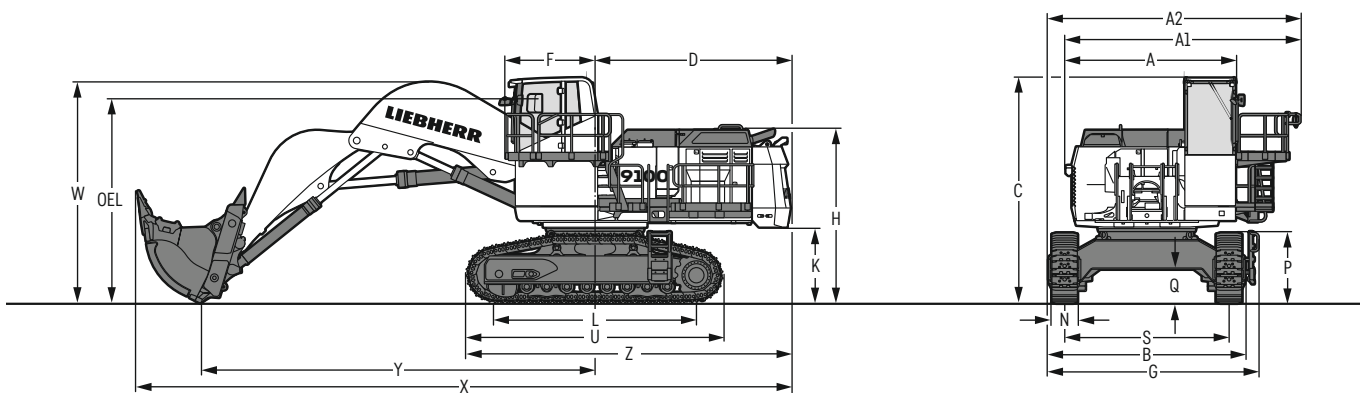

	mm / ft in
A	4,059 / 13'3"
A1	5,443 / 17'9"
A2	5,856 / 19'2"
B	4,685 / 15'4"
C	5,340 / 17'5"
D	4,630 / 15'2"
F	2,107 / 6'9"

	mm / ft in
G	4,995 / 16'4"
H	4,114 / 13'5"
K	1,803 / 5'9"
L	4,810 / 15'8"
N	500 / 1'6"
	600 / 2'
	750 / 2'5"

	mm / ft in
P	1,663 / 5'5"
Q	812 / 2'7"
S	3,900 / 12'8"
U	6,107 / 20'
V1	12,350 / 40'5"
W1	6,035 / 19'8"

	mm / ft in
X1	15,530 / 51'
Z	7,683 / 25'2"
OEL (Operator's eye level)	4,733 / 15'5"

Backhoe attachment (standard)

with boom 7.60 m / 24'9"

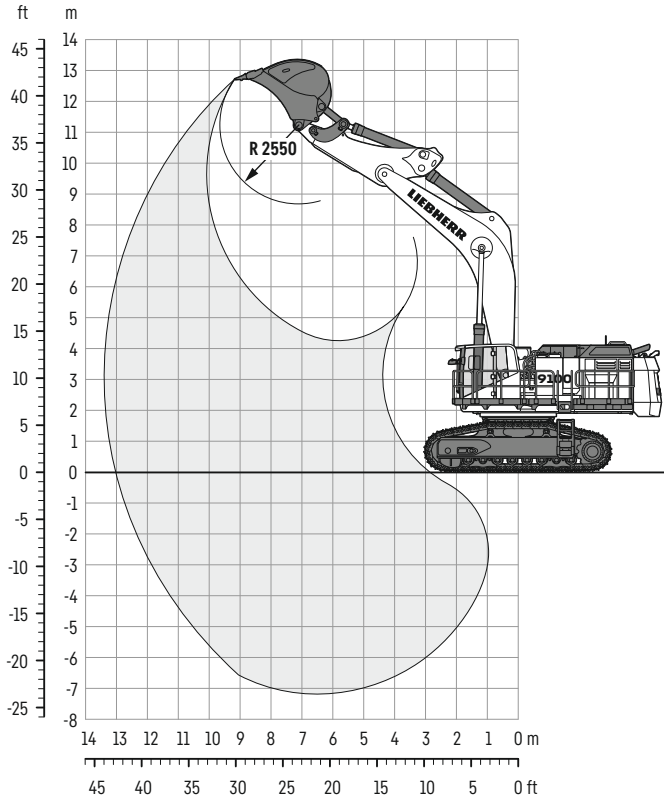

Digging envelope

Stick length	m	3.20
	ft in	10'5"
Max. digging depth	m	7.15
	ft in	23'5"
Max. reach at ground level	m	13.00
	ft in	42'7"
Max. dumping height	m	8.65
	ft in	28'4"
Max. teeth height	m	12.70
	ft in	41'7"

Forces

Max. digging force (ISO 6015)	kN	415
	lbf	93,296
Max. breakout force (ISO 6015)	kN	560
	lbf	125,893

Operating weight and ground pressure

The operating weight includes the basic machine with boom 7.60 m / 24'9", stick 3.20 m / 10'5" and bucket 7.50 m³ / 9.8 yd³.

		HD	
		600	750
Undercarriage			
Pad width	mm ft in	600 2'	750 2'5"
Weight	kg	112,717	113,733
	lb	248,498	250,738
Ground pressure*	kg/cm ²	1.79	1.44
	psi	25.46	20.48

* according to ISO 16754

Backhoe buckets

For materials class according to VOB, Section C, DIN 18300		< 5	< 5	< 5	5 - 6	5 - 6	5 - 6	5 - 6	7 - 8	7 - 8	7 - 8
Typical operation according to VOB, Section C, DIN 18300		GP	GP	GP	HD	HD	HD	HD	XHD	XHD	XHD
Capacity ISO 7451	m ³	9.00	8.40	7.70	8.00	7.00	7.50	7.00	7.50	6.50	6.00
	yd ³	11.8	11.0	10.1	10.5	9.2	9.8	9.2	9.8	8.5	7.8
Suitable for material up to a specific weight of	t/m ³	1.5	1.65	1.8	1.65	1.8	1.8	1.95	1.65	2.0	2.2
	lb/yd ³	2,528	2,781	3,034	2,781	3,034	3,034	3,287	2,781	3,371	3,708
Weight	kg	7,200	7,000	6,900	7,700	7,200	7,450	7,200	8,520	7,710	7,420
	lb	15,873	15,432	15,212	16,976	15,873	16,424	15,873	18,783	16,998	16,358

GP: General purpose bucket with Liebherr Z90 teeth
 HD: Heavy-duty bucket with Liebherr Z100 teeth
 XHD: Heavy-duty rock bucket with Liebherr Z100 teeth

Backhoe attachment

with boom 9.20 m / 30'2"

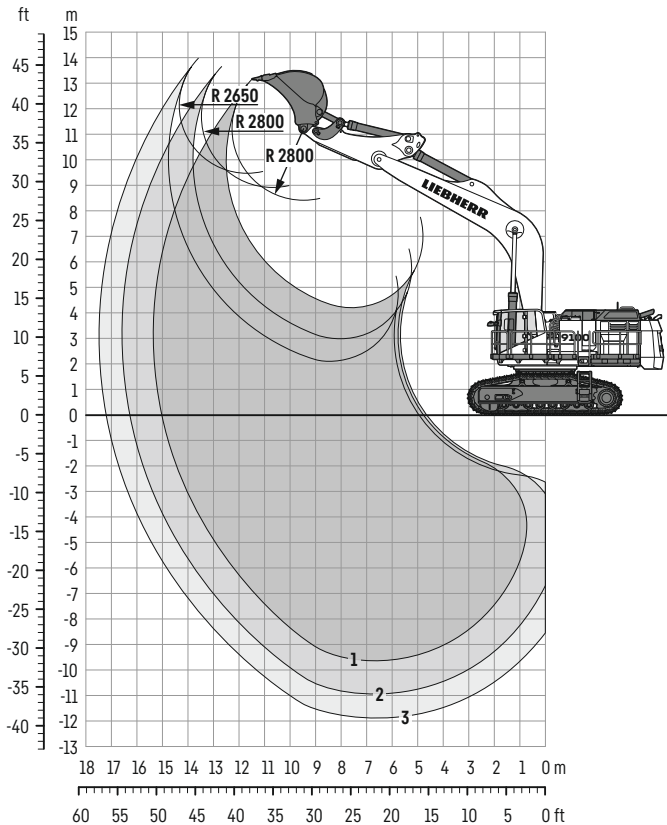

Digging envelope

		1	2	3
Stick length	m	3.20	4.50	5.60
	ft in	10'5"	14'8"	18'4"
Max. digging depth	m	9.64	10.94	11.90
	ft in	31'6"	35'9"	39'
Max. reach at ground level	m	15.02	16.20	17.20
	ft in	49'3"	53'1"	56'4"
Max. dumping height	m	8.40	8.90	9.40
	ft in	27'6"	29'2"	30'8"
Max. teeth height	m	13.16	13.60	13.90
	ft in	43'2"	44'6"	45'6"

Forces

		1	2	3
Max. digging force (ISO 6015)	kN	410	330	285
	lbf	92,172	74,187	64,071
Max. breakout force (ISO 6015)	kN	530	530	530
	lbf	119,149	119,149	119,149

Operating weight and ground pressure

The operating weight includes the basic machine with boom 9.20 m / 30'2", stick 4.50 m / 14'8" and bucket 4.50 m³ / 5.9 yd³.

		HD	
		600	750
Undercarriage	Pad width	600	750
		2'	2'5"
Weight	kg	112,464	113,480
	lb	247,941	250,181
Ground pressure*	kg/cm ²	1.78	1.44
	psi	25.32	20.48

* according to ISO 16754

Backhoe buckets

For materials class according to VOB, Section C, DIN 18300	< 5	5 - 6	5 - 6	5 - 6	5 - 6	5 - 6
Typical operation according to VOB, Section C, DIN 18300	GP	HD	HD	HD	HD	HD
Capacity ISO 7451	m ³	6.50	5.80	5.50	4.50	3.80
	yd ³	8.5	7.6	7.2	5.9	5.0
Suitable for material up to a specific weight of						
with stick 3.20 m	t/m ³	1.2	1.5	1.8	2.0	2.2
with stick 10'5"	lb/yd ³	2,023	2,528	3,034	3,371	3,708
with stick 4.50 m	t/m ³	-	1.2	1.4	1.8	2.0
with stick 14'8"	lb/yd ³	-	2,023	2,361	3,034	3,371
with stick 5.60 m	t/m ³	-	-	1.2	1.5	1.8
with stick 18'4"	lb/yd ³	-	-	2,023	2,528	3,034
Weight	kg	6,800	7,100	6,300	5,300	4,600
	lb	14,991	15,653	13,889	11,685	10,141

GP: General purpose bucket with Liebherr Z90 teeth

HD: Heavy-duty bucket with Liebherr Z100 teeth

Face shovel attachment

with boom 5.30 m / 17'4"

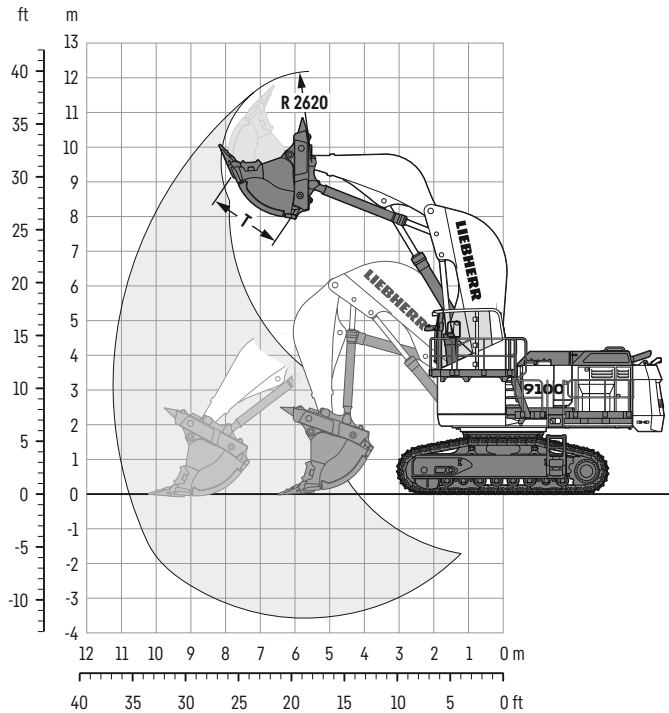

Digging envelope

Stick length	m	3.70
	ft in	12'1"
Max. reach at ground level	m	10.70
	ft in	35'1"
Max. dumping height	m	8.00
	ft in	26'2"
Max. crowd length	m	3.70
	ft in	12'1"
Bucket opening width T	mm	2,000
	ft in	6'6"

Forces

Max. crowd force at ground level (ISO 6015)	kN	545
	lbf	122,521
Max. crowd force (ISO 6015)	kN	704
	lbf	158,266
Max. breakout force (ISO 6015)	kN	585
	lbf	131,513

Operating weight and ground pressure

The operating weight includes the basic machine with shovel attachment and bucket 7.30 m³ / 9.6 yd³.

Undercarriage		HD	
		600	750
Pad width	mm	600	750
	ft in	2'	2'5"
Weight	kg	116,391	117,407
	lb	256,598	258,838
Ground pressure*	kg/cm ²	1.84	1.49
	psi	26.17	21.19

* according to ISO 16754

Face shovel buckets

For materials class according to VOB, Section C, DIN 18300	< 5	< 5	5 - 6	5 - 6	5 - 6	5 - 6	7 - 8	7 - 8	7 - 8	
Typical operation according to VOB, Section C, DIN 18300	GP	GP	HD	HD	HD	HD	XHD	XHD	XHD	
Capacity ISO 7451	m ³	9.00	7.80	7.80	7.30	6.70	5.90	7.30	6.70	5.80
	yd ³	11.8	10.2	10.2	9.6	8.8	7.7	9.6	8.8	7.6
Suitable for material up to a specific weight of	t/m ³	1.3	1.7	1.6	1.8	2.0	2.4	1.5	1.8	2.2
	lb/yd ³	2,191	2,865	2,697	3,034	3,371	4,045	2,528	3,034	3,708
Weight	kg	12,700	11,500	12,200	11,600	11,200	10,600	13,400	12,600	11,800
	lb	27,999	25,353	26,896	25,574	24,692	23,369	29,542	27,778	26,015

GP: General purpose bucket with Liebherr Z90 teeth

HD: Heavy-duty bucket with Liebherr Z100 teeth

XHD: Heavy-duty rock bucket with Liebherr Z100 teeth

Optional equipment

Undercarriage

Narrow track pad width
Large track pad width
Removable side frames
HD travel gear for muddy applications
Rock protection for idler wheel
Protection for undercarriage center frame
Full length chain guide

Uppercarriage

Increased fuel tank capacity (24h operation)
Grid protection for front headlights
Semi-automatic swing brake with joystick control
Wiggins couplings for ground level access service
Wiggins fast fueling system with Multiflo Hydrau-Flo®
Steel grease lines on swing ring
Hydraulically operated 45° access stair
Swing ring scrapers
External grease refill station (hydraulic-powered)
Right-hand bumper
External starting device
Rock protection for swing gear and grease lines
Heavy-duty engine air filtration system for very harsh conditions

Hydraulic system

Oil cooler inlet screen

Cab

4-point seat belt
Cab elevation (500 mm / 1'6" / 1,200 mm / 3'9" / 1,600 mm / 5'3")
Cab pressurization / cab pressurization with HEPA filter
FOPS top guard with additional sun protection
Operator comfort package
Front protective grid
Pre-heating system for cab
Roof glazing
External louvers

Attachment

Piston rod guard for bucket cylinder (BH)
Piston rod guard for hoist cylinder (FS)
Piston rod guard for stick cylinder (FS)
Quick change coupling

Specific solutions

Arctic package (-20 °C / -4 °F, -35 °C / -31 °F, -50 °C / -58 °F)
Sound attenuation package
Hydraulic arrangement for special application (hammer / shear / grapple / coupler)

Safety

Additional LED lighting with timer (for main access)
Automatic fire suppression system
Additional emergency stop (ground level)

General

Maritime transport packaging

Subject to technical modifications. All comparisons and claims of performance are made with respect to the prior Liebherr model unless specifically stated.

Liebherr-Mining Equipment Colmar SAS

49 rue Frédéric Hartmann • 68025 Colmar Cedex, France • Phone +33 369 49 20 00
info.lec@liebherr.com • www.liebherr.com • www.facebook.com/LiebherrMining