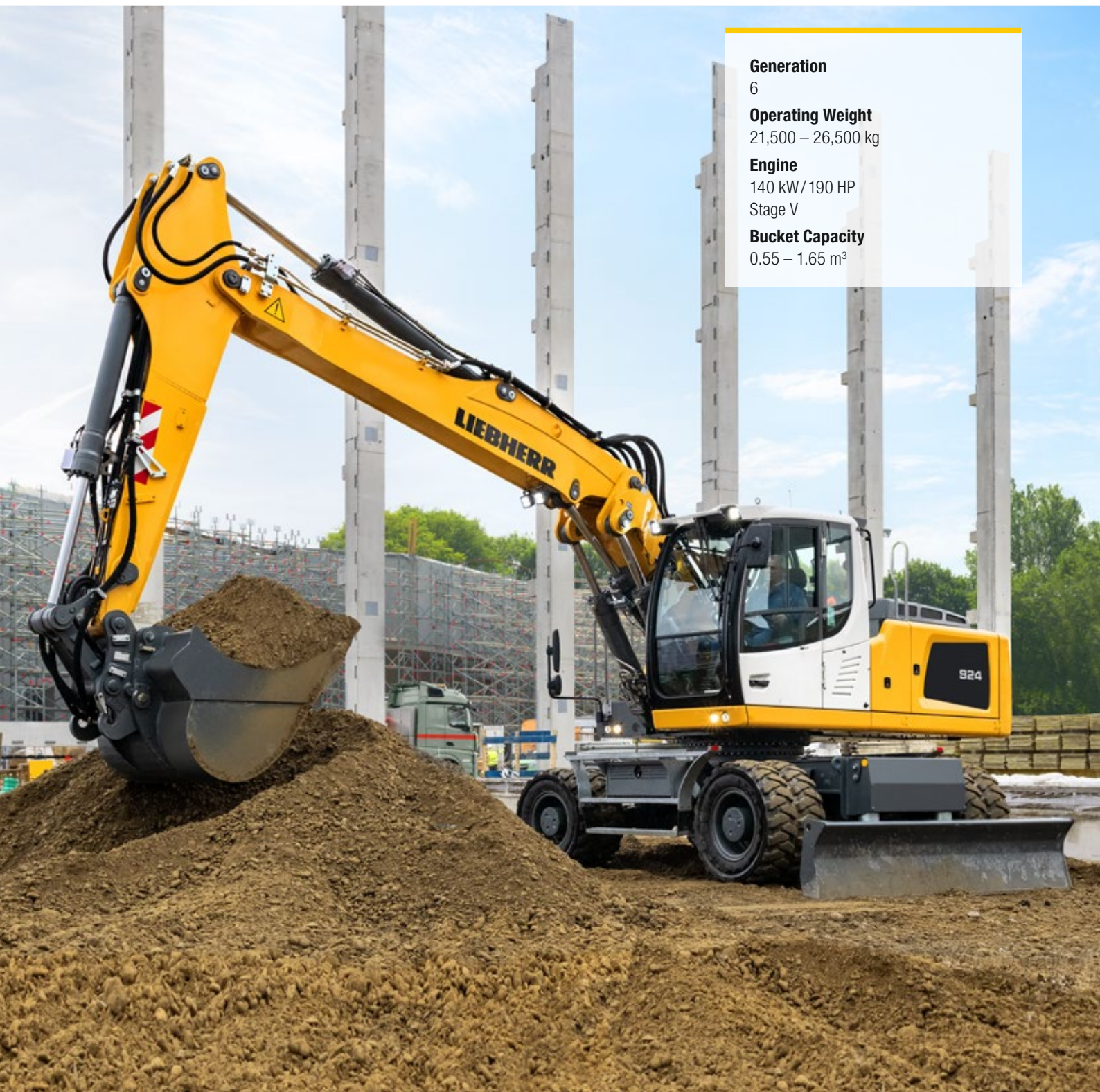

Wheeled Excavator

A 924

Litronic®

**Generation**

6

Operating Weight

21,500 – 26,500 kg

Engine

140 kW/ 190 HP

Stage V

Bucket Capacity

0.55 – 1.65 m³

LIEBHERR

Performance

Durably Stable Power,
Strength and Precision

Economy

A Sound Investment – Optimum Economy
and Environmentally Friendly

Operating Weight

21,500 – 26,500 kg

Engine

120 kW/190 HP
Stage V

Bucket Capacity

0.55 – 1.65 m³



Reliability

Competence, Consistency,
Innovation – Proven Experience

Comfort

Ergonomic Excellence – Superior Cabin
Design for Operator Comfort and Wellbeing

Maintainability

Service Every Step of the Way –
Simple, Fast and Reliable



Performance



Durably Stable Power, Strength and Precision

Liebherr wheeled excavators are used on building sites all over the world, where they embody force and speed. Using Liebherr excavators, machine operators achieve impressive levels of performance, day-in and day-out. Whether in classic earthmoving, in roadway construction or for digging trenches and laying pipes, more can be achieved faster with Liebherr wheeled excavators.

Maximum Performance

Being More Efficient

The A 924 Litronic combines power and dynamic properties. This makes it possible to complete heavy-duty earthmoving jobs faster, so that new tasks can be started sooner. As a result, this wheeled excavator is the efficient solution for use on all construction sites which require a high digging performance and mobile flexibility.

Heavy-duty Equipment

Liebherr has designed heavy-duty equipment for applications where wear is especially high, for instance when permanently working on supports, frequent turnover of high loads, demolition work or working with a long stick. The reinforced box construction forms the basis for a long service life of the equipment.

High Swing Torque

The separate hydraulic pump in the closed slewing circuit only supplies hydraulic fluid to the swing mechanism. The maximum delivery volume is thus available at any time for turning the uppercarriage for fast and dynamic rotational movements.



Precise Work

Working with Precision

The Liebherr joysticks enable the operator to intuitively and sensitively control the Liebherr hydraulic system to complete even the most challenging tasks quickly. Liebherr has been using an infinitely variable proportional controller with four axes for many years. The slim, ergonomically designed proportional sensors deliver additional functionality to the classic machine controller without having to reach for additional controls. Typical functions include high and medium pressure movements for tools as well as lowering the machine outrigger. Buttons on the joysticks, which the operator can configure, deliver additional convenience and functions.

Automatic Digging Brake

The automatic digging brake ensures that a manual actuation of the brake pedal is no longer required, thus leading to easier operation of the machine. If the machine is at a standstill, the digging brake is automatically applied. Furthermore, the automatic digging brake can be linked with the automatic swing axle lock.

Travel Drive

- High traction for fast acceleration and powerful engine permit top speed on hills
- Reduces unproductive travel time between tasks and on the building site
- Faster on site – More productive

Digging Force

- High digging and breakout force
- Continuously high digging performance even in tough ground
- More digging force for faster results

Joystick Steering

- The optional joystick steering function enables the operator to steer the wheeled excavator using the mini-joystick
- Working and travelling movements can be executed simultaneously without having to move hands
- More efficient operation for greater productivity

Economy



A Sound Investment – Optimum Economy and Environmentally Friendly

Liebherr wheeled excavators are machines that combine high productivity with excellent levels of economy – and all this comes as standard from the factory. On request, the efficiency of each wheeled excavator can be boosted further with a Liebherr productive bucket, a fuel-saving Liebherr hydraulic oil or a Liebherr quick coupling system, all of which provide more return from each operating hour.

Maximum Efficiency

Fuel Efficiency

The Liebherr D934 diesel engine minimizes environmental impact with low fuel consumption and reduced emissions. To achieve emissions standard V, Liebherr employs an innovative SCR system (selective catalytic reduction) with particle filter. The system was developed in-house and effectively reduces exhaust emissions without any compromise in performance.

Liebherr Working Tools and LIKUFIX

To boost the productivity of its construction machines, Liebherr offers a broad range of working tools for different fields of application. Furthermore, the hydraulic excavators can also be equipped with the Liebherr LIKUFIX hydraulic quick coupling system. The combination of a hydraulic Liebherr quick coupling system with the LIKUFIX coupling block permits fast safe changing of mechanical and hydraulic working tools from the operator's cabin. This boosts productivity on average by 30%. The construction process is accelerated, and orders are completed faster. That enables more turnover to be achieved per machine.

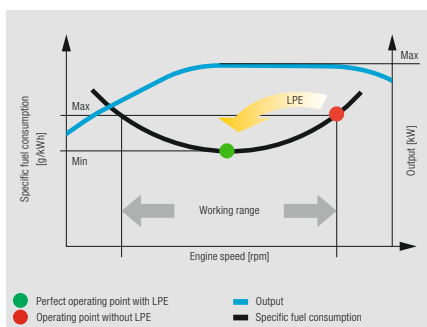

Increased Productivity

Efficient Management

LiDAT, Liebherr's own data transmission and positioning system, facilitates efficient management, monitoring and control of the entire fleet in terms of machinery data recording, data analysis, fleet management and service. All of the important machinery data can be viewed at any time on a web browser. LiDAT provides you comprehensive work deployment documentation, greater availability thanks to shorter downtimes, faster support from the manufacturer, quicker detection of strain/overload and subsequently a longer service life of the machine as well as greater planning efficiency. This service includes 1 year of use free of charge as standard for the wheeled excavator A 924.

Low: Emissions and Operating Costs

- Innovative SCR system with particle filter for compliance with emissions standard V
- Lower emissions – Lower operating costs – Economic environmental protection

Low Fuel Consumption Thanks to Intelligent Machine Control

- Liebherr-Power Efficiency (LPE) optimises the interaction of the drive components in terms of efficiency
- LPE enables machine operation in the area of the lowest specific fuel use for less consumption and greater efficiency with the same performance

High Resale Value

- High quality materials and quality workmanship ensure lengthy operation whilst retaining the highest possible value

Reliability



Competence, Consistency, Innovation – Proven Experience

Reliability offers safety. Safety that significantly influences the success of a project. Whatever the weather, Liebherr stands for safety – with reliable construction machines and customer-oriented sales and service partners. This means a Liebherr construction machine is exactly what it should be: an investment that pays off.

High Machine Availability

Quality and Competence

Our product experience, our understanding of technical design and feedback from customers, along with sales and service, form the basis for the use of pioneering ideas and have always been an integral part of our recipe for success. In addition, Liebherr has been delivering great production depth and system solutions for decades. Key components such as the diesel engine, electronic components, slewing ring, slewing drive and hydraulic cylinders are developed and manufactured in-house. Our great production depth guarantees the highest quality possible and allows the components to be coordinated perfectly.

Robust Construction

All the steel components are designed and manufactured by Liebherr. High strength steel sheets designed to withstand the harshest requirements guarantee high torsion resistance and excellent absorption of forces to ensure a long service life.

Greater Safety

Safety

Besides the performance and efficiency of a wheeled excavator, the safety of the operator and the machine must always be paramount. Numerous equipment features such as the standard pipe break protection on the lifting and stick cylinders, electronic height limitation, overload warning system, impact-resistant laminated safety glass, rollover protection system (ROPS) and an emergency exit through the rear window provide maximum safety in all operations.

Maximum Stability

A robust undercarriage with securely welded outriggers deliver safe footing, maximum stability and a long service life. The stabilizer blade as well as the outriggers have been designed for the toughest scenarios, allowing the machine to reliably carry out its work at full load.

Pipe Fracture Safety Valves

The standard pipe fracture safety valves on the stick and hoist cylinders prevent the attachments from dropping in an unregulated way and ensure maximum safety during every operation.



QPDM – Quality and Process Data Management

- QPDM allows production data to be logged, documented and evaluated
- Automation of documentation and test specifications
- Ability to handle large quantities and maintain uniform high quality

All-round Visibility

- Skyview 360° camera system for easy monitoring of the danger zones around the machine
- High working speed thanks to improved all-round visibility
- Less down time due to lower accident and damage risk
- Increased safety and flexibility in restricted spaces

Bright and Durable

- The LED rear lights fitted as standard not only look good, they also have a high brightness level and an extremely long service life
- The LED front outline marker fitted as standard make it easier to see the machine on the road, and thus provides greater safety

Comfort



Ergonomic Excellence – Superior Cabin Design for Operator Comfort and Wellbeing

The modern Liebherr operator's cab offers the best conditions for healthy, focussed and productive working. Standard features include an air-sprung operator seat with seat heating, automatic air conditioning and the ergonomically arranged control elements with touch screen indicating unit. An example of the extensive safety equipment is the roll-over protection system (ROPS) for the cab fitted as standard according to ISO 12117-2.

First-class Cab

Automatic Air Conditioning

Liebherr fits the A 924 with a standard automatic air conditioning system to ensure operator comfort. The temperature, fan setting and the various air vents at head, chest and foot levels can be adjusted through the intuitive operation of the touchscreen. The defrost/defog one-button function clears fogged up windows in the shortest possible time. The filter for the cab air can be changed easily and conveniently from outside.

Operator Seats

The Standard, Comfort and Premium operator's seat versions deliver maximum comfort.

Even the Standard operator's seat has been manufactured with high-quality materials and has an extensive selection of standard equipment including pneumatic suspension, seat heating, headrest, lumbar support and much more.

A luxury which we believe every construction machine should provide.

Smooth Operation

The use of visco-elastic mounts, good noise insulation and modern, smooth Liebherr diesel engines minimise noise emissions and vibrations. The noise levels are just 72 dB(A) in the operator's cab and 103 dB(A) outside.



Refuelling

- Using the optional refuelling pump, the machine can be refuelled directly from a fuel container
- Remote cable operation and automatic shut off when the tank is full, for greater convenience and shorter refuelling times
- Topping up – simple, quick and safe

Sliding Two-piece Windscreen

- Unrestricted view of the working area by sliding in the windscreen
- Simple mechanism for rapid and intuitive opening
- Windscreen can be split in two

Intuitive Operation

- Display of the machine data and camera image on the 7-inch indicating unit with touch screen and direct access via menu bar
- 20 user-programmable memory slots for working tools, which can be used for quickly and easily setting the oil pressure and oil flow at the push of a button when changing tools
- Quick access keys can be programmed by the machine operator for frequently used menu items

Comfortable Operation

Radio with Hands-free Device

The optional Liebherr radio is MP3-compatible, has a USB connection and can be used as interface for the integral hands-free kit. If the machine operator connects his smartphone to the radio using Bluetooth, the touchscreen can be used to control phone calls. This means that all media, including the radio, MP3 or phone calls, are controlled using a central unit which provides greater clarity, simplicity and comfort.

Control Unit

The large touchscreen provides the operator with a fast, uncomplicated interface which delivers all the information required for working with the machine. A flat, intuitive menu system ensures that it can be readily understood so that the control unit can be used in a highly productive way.

Pleasant Climate

The use of an efficient auxiliary heater significantly enhances cab comfort, productive work time and safety. The upstream warm-up phase also protects the engine components and reduces wear.

Maintainability



Exceptional Service and a Reliable Partnership

Liebherr wheeled excavators are not only powerful, robust, precise and efficient, they also impress with the service-orientated machine design. Maintenance is performed quickly, simply and safely. This reduces maintenance costs and keeps machine downtimes to a minimum.

Simplified Maintenance Concept

Hydraulic Oils with Added Value

Liebherr hydraulic oils achieve a service life of 6,000 operating hours plus. Instead of having defined change intervals, the results of the oil analysis (every 1,000 operating hours or after one year) determine when the oil needs to be changed. The unique Liebherr Hydraulic Plus oil can even achieve a service life of 8,000 operating hours plus at the same time reducing fuel consumption by up to 5%.

Retrofitting with New Technologies

New emission standards, amended safety regulations or different areas of deployment – the demands on your machine can change as years go by. Protective grilles, additional filter systems and options for hydraulics are just a small selection from the Liebherr retrofit program with which we offer you an effective way to modify or retrofit your machine.

Your Competent Service Partner

Remanufacturing

The Liebherr remanufacturing program offers cost-effective reconditioning of components to the highest quality standards. Various reconditioning levels are available including replacement components and general overhaul or repair. The customer receives components with original part quality at a reduced cost.

Competent Advice and Service

Competent advice is a given at Liebherr. Experienced specialists provide advice for your specific requirements: application-oriented sales support, service agreements, cost effective repair alternatives, original parts management, as well as remote data transmission for machine planning and fleet management.



Lubricating During Work

- Fully automatic central lubrication system for the attachment and swing ring
- Can be optionally expanded to the connecting link and quick coupler
- Lubricating without interrupting work for higher productivity

Optimum Service Access

- Large, wide-opening and automatically locking service doors
- Engine oil, fuel, air and cab air filter can be reached conveniently and safely from ground level
- The oil level in the hydraulic tank can be checked from the cab
- Short service times for greater productivity

Rapid Spare Parts Service

- 24-hour delivery: Spare parts service is available for our dealers around the clock
- Electronic spare parts catalogue: Fast and reliable selection and ordering via the Liebherr online portal
- With online tracking, the current processing status of your order can be viewed at any time

Wheeled Excavator A 924 Litronic

Overview

Superbly Designed Attachment for Maximum Reliability

- Liebherr hydraulic cylinders
- Wide selection of Liebherr working tools (optional)
- Liebherr quick coupling systems (optional)
- Pipe fracture safety valves for hoisting and stick cylinders
- Overload warning device
- Load holding valve on stabilization cylinder
- Mono boom, HD version (optional)

Elaborate Maintenance Concept for Maximum Productivity

- Fully automatic central lubrication system for uppercarriage and attachment
- Large, wide-opening service doors
- Central maintenance points accessible from the ground
- Hydraulic shut-off cock
- Liebherr hydraulic oil biologically degradable (optional)
- Cab air filter can be replaced quickly and conveniently from outside
- Storage compartment left – lockable
- Extended tool equipment (optional)





Ergonomic Operator's Work Station for Maximum Comfort

- Operator's seat Comfort/Premium (optional)
- Automatic air-conditioning system
- 7" colour touchscreen display
- Direct access keys
- Adjustable armrests
- Resonant, ergonomic joysticks
- Joystick steering
- Proportional control with mini-joystick
- Tool Control for working tools
- Large windows
- Easy radio control
- Front guard, adjustable (optional)
- Cab windows made from smash-resistant laminated safety glass (optional)
- LED lights (optional)
- Rear and side camera monitoring
- Skyview 360° (optional)

Clever Technology for Maximum Performance and Economy

- Liebherr diesel engine compliant with stage V
- Full power at just 1,700 rpm
- Emissions treatment with Liebherr-SCR technology and particle filter
- Load-sensing-control
- Liebherr-Power Efficiency (LPE)
- MODE selection (Sensitive, ECO, Power, Power-Plus)
- Sensor-controlled automatic idling system
- Close-mesh protective grid in front of cooler intake
- Closed hydraulic circuit for the swing mechanism

Technical Data



Diesel Engine

Rating per ISO 9249	140 kW (190 HP) at 1,700 RPM
Model	Liebherr D934
Type	4 cylinder in-line
Bore/Stroke	122 / 150 mm
Displacement	7.0 l
Engine operation	4-stroke diesel Common-Rail turbo-charged and after-cooled reduced emissions
Air cleaner	dry-type air cleaner with pre-cleaner, primary and safety elements
Engine idling	sensor controlled
Electrical system	
Voltage	24 V
Batteries	2 x 135 Ah / 12 V
Alternator	three-phase current 28 V / 140 A
Stage V	
Harmful emissions values	according to regulation (EU) 2016/1628
Emission control	Liebherr-SCRFilter technology
Fuel tank	330 l
Urea tank	46 l



Cooling System

Diesel engine	water-cooled compact cooling system consisting cooling unit for water, hydraulic oil and charge air with stepless thermostatically controlled fan
----------------------	--



Hydraulic Controls

Power distribution	via control valves in single block with integrated safety valves
Servo circuit	
Equipment and swing	with hydraulic pilot control and proportional joystick levers
Chassis	electroproportional via foot pedal
Additional functions	via switch or electroproportional foot pedals
Proportional control	proportionally acting transmitters on the joysticks for additional hydraulic functions



Hydraulic System

Hydraulic pump	
for equipment and travel drive	2 Liebherr axial piston variable displacement pumps (double construction)
Max. flow	2 x 231 l/min.
Max. pressure for swing drive	350 bar reversible axial piston variable displacement pump, closed-loop circuit
Max. flow	140 l/min.
Max. pressure	420 bar
Hydraulic pump regulation and control	Liebherr-Synchron-Comfort-system (LSC) with electronic engine speed sensing regulation, pressure and flow compensation, torque controlled swing drive priority
Hydraulic tank	175 l
Hydraulic system	max. 430 l
Hydraulic oil filter	1 main return filter with integrated partial micro filtration (5 µm)
MODE selection	adjustment of engine and hydraulic performance via a mode pre-selector to match application, e.g. for especially economical and environmentally friendly operation or for maximum digging performance and heavy-duty jobs
S (Sensitive)	mode for precision work and lifting through very sensitive movements
E (Eco)	mode for especially economical and environmentally friendly operation
P (Power)	mode for high performance with low fuel consumption
P+ (Power-Plus)	mode for highest performance and for very heavy duty applications, suitable for continuous operation
Engine speed and performance setting	stepless alignment of engine output and hydraulic power via engine speed
Option	Tool Control: 20 preadjustable pump flows and pressures for add-on attachments



Swing Drive

Drive	Liebherr axial piston motor in a closed system, Liebherr planetary reduction gear
Swing ring	Liebherr, sealed race ball bearing swing ring, internal teeth
Swing speed	0 – 10.0 RPM stepless
Swing torque	76 kNm
Holding brake	wet multi-disc (spring applied, pressure released)
Option	pedal controlled positioning swing brake slewing gear brake Comfort



Operator's Cab

Cab	ROPS safety cab structure (roll-over protection system) with individual windscreens or featuring a slide-in subpart under the ceiling, work headlights integrated in the ceiling, a door with a sliding window (can be opened on both sides), large stowing and depositing possibilities, shock-absorbing suspension, sounddamping insulating, tinted laminated safety glass, separate window shades for the sunroof window and windscreen
Operator's seat Standard	air cushioned operator's seat with 3D-adjustable armrests, headrest, lap belt, seat heater, manual weight adjustment, adjustable seat cushion inclination and length and mechanical lumbar vertebrae support
Operator's seat Comfort (Option)	in addition to operator's seat standard: lockable horizontal suspension, automatic weight adjustment, adjustable suspension stiffness, pneumatic lumbar vertebrae support and passive seat climatisation with active coal
Operator's seat Premium (Option)	in addition to operator's seat comfort: active electronic weight adjustment (automatic re-adjustment), pneumatic low frequency suspension and active seat climatisation with active coal and ventilator
Control system	joysticks with control consoles and swivel seat, folding left control console
Operation and displays	large high-resolution operating unit, self-explanatory, colour display with touchscreen, video-compatible, numerous setting, control and monitoring options, e.g. air conditioning control, fuel consumption, machine and attachment parameters
Air-conditioning	automatic air-conditioning, recirculated air function, fast de-icing and demisting at the press of a button, air vents can be operated via a menu; recirculated air and fresh air filters can be easily replaced and are accessible from the outside; heating-cooling unit, designed for extreme outside temperatures, sensors for solar radiation, inside and outside temperatures
Refrigerant	R134a
Global warming potential	1,430
Quantity at 25 °C	1,300 g
CO ₂ equivalent	1.859 t
Vibration emission*	
Hand/arm vibrations	< 2.5 m/s ²
Whole-body vibrations	< 0.5 m/s ²
Measuring inaccuracy	according with standard EN 12096:1997



Undercarriage

Drive	oversized two speed power shift transmission with additional creeper speed, Liebherr axial piston motor with functional brake valve on both sides
Pulling force	129 kN
Travel speed	0 – 3.5 km/h stepless (creeper speed off-road) 0 – 7.0 km/h stepless (off-road) 0 – 13.0 km/h stepless (creeper speed on-road) 0 – 20.0 km/h stepless (road travel) 0 – max. 25.0 km/h Speeder (Option)
Driving operation	automotive driving using accelerator pedal, cruise control function: storage of variable accelerator pedal positions, both off-road and on-road
Axles	manual or automatic hydraulically controlled front axle oscillation lock
Service brake	two circuit travel brake system with accumulator; wet and backlash-free disc brake
Automatic digging brake	works automatically when driving off (accelerator pedal actuation) and when the machine is stationary (engagement); the digging brake engages automatically – can be coupled with automatic swing axle lock
Holding brake	wet multi-disc (spring applied, pressure released)
Stabilization	rear stabilizer blade (adjustable during travel for dozing) rear stabilizer blade + front outriggers rear outriggers + front stabilizer blade rear + front outriggers
Option	EW-undercarriage 2.75 m/9'



Equipment

Type	high-strength steel plates at high-stressed points for the toughest requirements. Complex and stable mountings of equipment and cylinders
Hydraulic cylinders	Liebherr cylinders with special seal system as well as shock absorption
Bearings	sealed, low maintenance



Complete Machine

Lubrication	Liebherr central lubrication system for upper-carriage and equipment, automatically	
Noise emission		
ISO 6396	L _{PA} (inside cab)	= 72 dB(A)
2000/14/EC	L _{WA} (surround noise)	= 103 dB(A)

* for risk assessment according to 2002/44/EC see ISO/TR 25398:2006

Dimensions

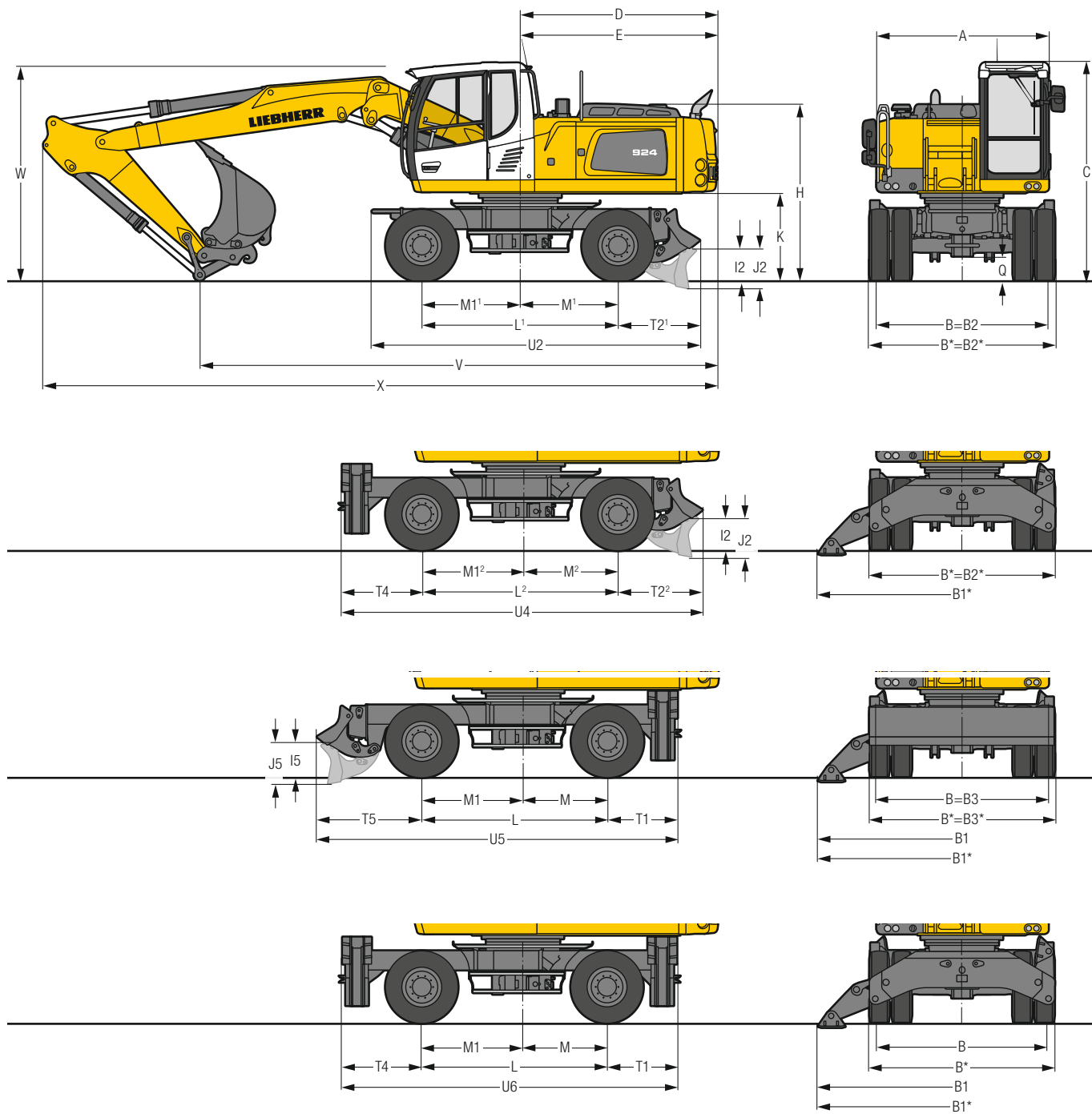

	mm
A	2,525
B	2,550
B*	2,750
B1	4,015
B1*	4,260
B2	2,550
B2*	2,750
B3	2,550
B3*	2,750
C	3,220
D	2,900
E	2,900
H	2,605
I2	467
I5	465
J2	590
J5	590
K	1,280
L	2,750
L¹⁾	2,900
L²⁾	2,900
M	1,250
M¹⁾	1,450
M²⁾	1,400
M1	1,500
M1¹⁾	1,450
M1²⁾	1,500
Q	350
T1	1,040
T2¹⁾	1,210
T2²⁾	1,260
T4	1,190
T5	1,560
U2	4,850
U4	5,350
U5	5,350
U6	4,980

* EW-Undercarriage/ Tyres 11.00-20

¹⁾ Undercarriage – rear blade

²⁾ Undercarriage – rear blade + front outriggers

E = Tail radius

Tyres 10.00-20

Stick	Two-piece boom 5.80 m				
	Rear blade	Rear blade + front outriggers	Rear outriggers + front blade	Rear + front outriggers	
m	mm	mm	mm	mm	mm
V	2.25	7,650	7,650	7,650	7,650
	2.45	7,350	7,350	7,350	7,350
	2.65	7,000	7,000	7,000	7,000
	3.05	6,700	6,700	6,700	6,700
W	2.25	3,150	3,150	3,150	3,150
	2.45	3,150	3,150	3,150	3,150
	2.65	3,150	3,150	3,150	3,150
	3.05	3,200	3,200	3,200	3,200
X	2.25	9,950	9,950	9,950	9,950
	2.45	9,950	9,950	9,950	9,950
	2.65	9,950	9,950	9,950	9,950
	3.05	9,950	9,950	9,950	9,950

Stick	Mono boom 5.65 m				
	Rear blade	Rear blade + front outriggers	Rear outriggers + front blade	Rear + front outriggers	
m	mm	mm	mm	mm	mm
V	2.25	6,500	6,500	6,500	6,500
	2.45	6,350	6,350	6,350	6,350
	2.65	6,200	6,200*	6,350*	6,200*
	3.05	6,300	6,800* ¹⁾²⁾	6,950* ¹⁾²⁾	6,800* ¹⁾²⁾
W	2.25	3,250	3,250	3,250	3,250
	2.45	3,300	3,300	3,300	3,300
	2.65	3,300	3,350*	3,350*	3,350*
	3.05	3,400	3,400* ¹⁾	3,400* ¹⁾	3,400
X	2.25	9,600	9,600	9,600	9,600
	2.45	9,600	9,600	9,600	9,600
	2.65	9,650	9,650*	9,800*	9,650*
	3.05	9,650	9,650* ¹⁾	9,800* ¹⁾	9,650* ¹⁾

Dimensions are with equipment over steering axle

* Equipment over digging axle for shorter transport dimensions

¹⁾ without quick coupler

²⁾ tipping cylinder retracted

W = Max. ground clearance including approx. 150 mm piping

Backhoe Bucket

with Two-Piece Boom 5.80 m (Heavy Counterweight)

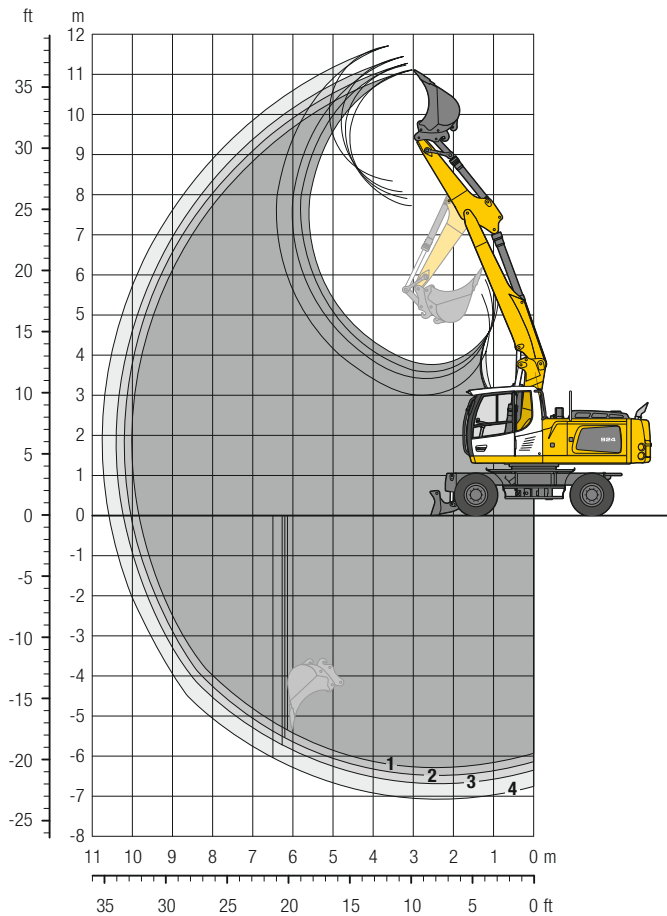

Digging Envelope

with quick coupler		1	2	3	4
Stick length	m	2.25	2.45	2.65	3.05
Max. digging depth	m	6.30	6.50	6.70	7.05
Max. reach at ground level	m	9.85	10.05	10.25	10.60
Max. dumping height	m	7.75	7.90	8.05	8.35
Max. teeth height	m	11.10	11.25	11.45	11.70
Min. equipment radius	m	3.25	3.15	3.10	3.15

Digging Forces

without quick coupler		1	2	3	4
Max. digging force (ISO 6015)	kN	126.9	119.2	112.4	101.1
	t	12.9	12.2	11.5	10.3
Max. breakout force (ISO 6015)	kN	140.6	140.6	140.6	140.6
	t	14.3	14.3	14.3	14.3

Max. breakout force with ripper bucket

186.0 kN (19.0 t)

Operating Weight

The operating weight includes the basic machine with 8 tyres plus intermediate rings, two-piece boom 5.80 m, stick 2.45 m, quick coupler SWA 48 and bucket 1,250 mm/1.15 m³.

Undercarriage versions	Weight (kg)
A 924 Litronic with rear blade	23,800
A 924 Litronic with rear blade + front outriggers	25,700
A 924 Litronic with rear outriggers + front blade	25,500
A 924 Litronic with rear + front outriggers	25,800
A 924 EW Litronic with rear blade	23,900
A 924 EW Litronic with rear blade + front outriggers	26,100
A 924 EW Litronic with rear outriggers + front blade	25,900
A 924 EW Litronic with rear + front outriggers	26,300

Buckets Machine stability per ISO 10567* (75% of tipping capacity)

Cutting width mm	Capacity ISO 7451 ¹⁾ m ³	Weight kg	Stabilizers raised				Rear blade down				Rear blade + front outriggers down				Rear outriggers + front blade down				Rear + front outriggers down			
			Stick length (m)				Stick length (m)				Stick length (m)				Stick length (m)				Stick length (m)			
			2.25	2.45	2.65	3.05	2.25	2.45	2.65	3.05	2.25	2.45	2.65	3.05	2.25	2.45	2.65	3.05	2.25	2.45	2.65	3.05
850 ²⁾	0.75	650	■	■	■	■	■	■	■	■	■	■	■	■	■	■	■	■	■	■	■	■
1,050 ²⁾	0.95	720	■	■	■	■	■	■	■	■	■	■	■	■	■	■	■	■	■	■	■	■
1,250 ²⁾	1.15	810	■	■	■	△	■	■	■	△	■	■	■	■	■	■	■	■	■	■	■	■
1,400 ²⁾	1.35	880	△	△	△	-	△	△	△	-	■	■	■	■	■	■	■	■	■	■	■	■
1,500 ²⁾	1.45	890	△	-	△	-	△	△	△	-	■	■	■	■	■	■	■	■	■	■	■	■
850 ³⁾	0.75	690	■	■	■	■	■	■	■	■	■	■	■	■	■	■	■	■	■	■	■	■
1,050 ³⁾	0.95	800	■	■	■	■	■	■	■	■	■	■	■	■	■	■	■	■	■	■	■	■
1,250 ³⁾	1.15	910	■	△	■	△	■	■	■	△	■	■	■	■	■	■	■	■	■	■	■	■
1,400 ³⁾	1.35	960	△	-	△	-	△	△	△	-	■	■	■	■	■	■	■	■	■	■	■	■
1,500 ³⁾	1.45	1,000	-	-	-	-	△	△	-	-	■	■	■	■	■	■	■	■	■	■	■	■
850 ⁴⁾	0.80	630	■	■	■	■	■	■	■	■	■	■	■	■	■	■	■	■	■	■	■	■
1,050 ⁴⁾	1.05	720	■	■	■	△	■	■	■	■	■	■	■	■	■	■	■	■	■	■	■	■
1,250 ⁴⁾	1.30	800	△	△	△	-	■	■	△	△	■	■	■	■	■	■	■	■	■	■	■	■
1,400 ⁴⁾	1.50	870	-	-	-	-	△	△	-	-	■	■	■	■	■	■	■	■	■	■	■	■
1,500 ⁴⁾	1.65	890	-	-	-	-	△	-	-	-	■	■	■	■	■	■	■	■	■	■	■	■

Buckets Machine stability per ISO 10567* (75% of tipping capacity)

Cutting width mm	Capacity ISO 7451 ¹⁾ m ³	Weight kg	EW Stabilizers raised				EW Rear blade down				EW Rear blade + front outriggers down				EW Rear outriggers + front blade down				EW Rear + front outriggers down			
			Stick length (m)				Stick length (m)				Stick length (m)				Stick length (m)				Stick length (m)			
			2.25	2.45	2.65	3.05	2.25	2.45	2.65	3.05	2.25	2.45	2.65	3.05	2.25	2.45	2.65	3.05	2.25	2.45	2.65	3.05
850 ²⁾	0.75	650	■	■	■	■	■	■	■	■	■	■	■	■	■	■	■	■	■	■	■	■
1,050 ²⁾	0.95	720	■	■	■	■	■	■	■	■	■	■	■	■	■	■	■	■	■	■	■	■
1,250 ²⁾	1.15	810	■	■	■	△	■	■	■	■	■	■	■	■	■	■	■	■	■	■	■	■
1,400 ²⁾	1.35	880	■	△	△	△	■	■	■	△	■	■	■	■	■	■	■	■	■	■	■	■
1,500 ²⁾	1.45	890	△	△	△	-	■	■	△	△	■	■	■	■	■	■	■	■	■	■	■	■
850 ³⁾	0.75	690	■	■	■	■	■	■	■	■	■	■	■	■	■	■	■	■	■	■	■	■
1,050 ³⁾	0.95	800	■	■	■	■	■	■	■	■	■	■	■	■	■	■	■	■	■	■	■	■
1,250 ³⁾	1.15	910	■	△	■	△	■	■	■	■	■	■	■	■	■	■	■	■	■	■	■	■
1,400 ³⁾	1.35	960	△	△	△	-	■	■	△	△	■	■	■	■	■	■	■	■	■	■	■	■
1,500 ³⁾	1.45	1,000	△	△	△	-	■	△	△	△	■	■	■	■	■	■	■	■	■	■	■	■
850 ⁴⁾	0.80	630	■	■	■	■	■	■	■	■	■	■	■	■	■	■	■	■	■	■	■	■
1,050 ⁴⁾	1.05	720	■	■	■	■	■	■	■	■	■	■	■	■	■	■	■	■	■	■	■	■
1,250 ⁴⁾	1.30	800	■	■	△	△	■	■	■	△	■	■	■	■	■	■	■	■	■	■	■	■
1,400 ⁴⁾	1.50	870	△	△	△	-	■	△	△	△	■	■	■	■	■	■	■	■	■	■	■	■
1,500 ⁴⁾	1.65	890	△	-	-	-	△	△	△	-	■	■	■	■	■	■	■	■	■	■	■	■

* Indicated loads are based on ISO 10567 and do not exceed 75% of tipping or 87% of hydraulic capacity, max. stick length without quick coupler, lifted 360° on firm with blocked oscillating axle

¹⁾ comparable with SAE (heaped)

²⁾ Bucket with teeth ³⁾ Bucket with teeth in HD-version ⁴⁾ Bucket with cutting edge (also available in HD-version)

Max. material weight ■ = ≤ 1.8 t/m³, ■ = ≤ 1.5 t/m³, △ = ≤ 1.2 t/m³, - = not authorised

Stick 2.65 m

m		Undercarriage stabilized		3.0 m		4.5 m		6.0 m		7.5 m		9.0 m		m	
rear	front														
9.0	9.0	4.7* 4.7*	4.7* 4.7*												5.3
7.5	7.5	3.7 4.0*	3.7 4.0*			5.0 5.7*	5.0 5.7*								7.0
6.0	6.0	2.9 3.7*	2.9 3.7*	5.7* 5.7*	5.0 6.1*	3.3 5.2*	3.3 5.2*								8.0
4.5	4.5	2.5 3.6*	2.5 3.6*	7.9* 7.9*	7.4 7.7*	4.9 7.3*	3.4 6.2*								8.6
3.0	3.0	2.2 3.6*	2.2 3.6*	12.6 14.6*	7.1 10.7*	4.8 7.9*	3.4 6.5*								9.0
1.5	1.5	2.1 3.8*	2.1 3.8*	12.3 14.0*	6.9 11.8*	4.7 8.5*	3.2 6.7*	2.2 4.1*							9.0
0	0	3.7 4.2*	3.7 4.2*	16.0* 16.0*	10.6 11.8*	7.1 8.5*	5.0 6.6*								8.8
-1.5	-1.5	2.3 4.8*	2.3 4.8*	11.9 18.8*	6.6 12.0*	4.3 8.6*	2.9 6.7*								8.4
-3.0	-3.0	2.7 4.2*	2.7 4.2*	11.7 19.7*	6.4 12.3*	4.0 8.7*	2.8 4.5*								7.6
-4.5	-4.5	4.0 4.9*	4.0 4.9*	11.6 18.7*	6.1 10.3*										5.9

Stick 3.05 m

m		Undercarriage stabilized		3.0 m		4.5 m		6.0 m		7.5 m		9.0 m		m	
rear	front														
9.0	9.0	3.9* 3.9*	3.9* 3.9*												5.9
7.5	7.5	3.1 3.4*	3.4* 3.4*			4.7 5.1*	5.0 5.1*								7.4
6.0	6.0	2.4 3.1*	2.7 3.1*			4.7 5.3*	3.2 4.9*								8.4
4.5	4.5	2.3 3.1*	2.3 3.1*	6.0* 6.0*	4.5 6.2*	3.5 5.7*	2.3 3.1*	2.1 3.1*							9.0
3.0	3.0	1.9 3.1*	2.1 3.1*	11.8 15.2*	6.6 10.2*	4.4 6.7*	3.2 4.9*	2.1 3.5	1.9 3.1*						9.3
1.5	1.5	1.8 3.0*	1.8 3.3*	12.3 14.1*	6.9 11.5*	4.7 8.3*	3.3 6.5*	2.2 5.1*	2.0 3.3*						9.4
0	0	1.8 3.2	1.8 3.6*	11.2 15.5*	6.3 9.8	4.3 6.6	2.9 4.7	1.9 3.3	1.8 3.2						9.2
-1.5	-1.5	1.9 3.4	2.1 4.1*	10.8 18.1*	6.0 10.0	4.0 6.6	2.6 4.5								8.8
-3.0	-3.0	2.2 3.9	2.4 4.2*	10.5 19.4	5.8 10.0	3.7 6.2	2.5 4.3								8.0
-4.5	-4.5	3.0 4.1*	3.3 4.1*	11.6 19.5*	6.4 12.1*	4.0 8.8*	2.7 5.7*								6.6

Height **Can be slewed through 360°** **In longitudinal position of undercarriage** **Max. reach** * Limited by hydr. capacity

The lift capacities on the load lift hook of the Liebherr quick coupler SWA 48 without attachment are stated in metric tons (t) and are valid on a firm, level supporting surface with blocked oscillating axle. These capacities can be slewed through 360° with the undercarriage in the transverse position. Capacities in the longitudinal position of the undercarriage (+/- 15°) are specified over the steering axle with the stabilizers raised and over the rigid axle with the stabilizers down. The values apply when the adjusting cylinder is in the optimal position. Indicated loads based on the ISO 10567 standard and do not exceed 75% of tipping or 87% of hydraulic capacity, or are limited by the permissible load of the load lift hook on the quick coupler (max. 12 t). Without the quick coupler, lift capacities will increase by up to 226 kg.

In accordance with the harmonised European Standard EN 474-5, hydraulic excavators used for lifting operations must be equipped with pipe fracture safety valves, an overload warning device, a load lift hook and a lift capacity chart.

Lift Capacities

with Two-Piece Boom 5.80 m (Heavy Counterweight), EW-Undercarriage

Stick 2.25 m		Undercarriage stabilized		3.0 m		4.5 m		6.0 m		7.5 m		9.0 m					
		m	m	m	m	m	m	m	m	m	m						
9.0	rear	–	–	–	–	–	–	–	–	–	–	–	–	5.7*	5.7*	4.6	
	front	–	–	–	–	–	–	–	–	–	–	–	–	5.7*	5.7*		
	Blade	–	–	–	–	–	–	–	–	–	–	–	–	5.7*	5.7*		
	Blade	Outriggers	–	–	–	–	–	–	–	–	–	–	–	5.7*	5.7*		
	Outriggers	Blade	–	–	–	–	–	–	–	–	–	–	–	5.7*	5.7*		
7.5	rear	–	–	–	–	–	–	–	–	–	–	–	–	4.7*	4.7*	6.4	
	front	–	–	–	–	–	–	–	–	–	–	–	–	4.7*	4.7*		
	Blade	–	–	–	–	–	–	–	–	–	–	–	–	4.7*	4.7*		
	Blade	Outriggers	–	–	–	–	–	–	–	–	–	–	–	4.7*	4.7*		
	Outriggers	Blade	–	–	–	–	–	–	–	–	–	–	–	4.7*	4.7*		
6.0	rear	–	–	–	–	–	–	–	–	–	–	–	–	3.3	4.3*	7.5	
	front	–	–	–	–	–	–	–	–	–	–	–	–	3.5	4.3*		
	Blade	–	–	–	–	–	–	–	–	–	–	–	–	4.3*	4.3*		
	Blade	Outriggers	–	–	–	–	–	–	–	–	–	–	–	4.3*	4.3*		
	Outriggers	Blade	–	–	–	–	–	–	–	–	–	–	–	4.3*	4.3*		
4.5	rear	–	–	13.7	14.2*	7.5	9.6*	5.0	6.9	3.4	4.9	–	–	2.8	4.1	8.2	
	front	–	–	14.2*	14.2*	8.1	9.6*	5.4	7.6*	3.7	6.5*	–	–	3.0	4.2*		
	Blade	–	–	14.2*	14.2*	9.6*	9.6*	7.6*	7.6*	5.8	6.4*	–	–	4.2*	4.2*		
	Blade	Outriggers	–	–	14.2*	14.2*	9.6*	9.6*	7.6*	7.6*	5.8	6.4*	–	–	4.2*		4.2*
	Outriggers	Blade	–	–	14.2*	14.2*	9.6*	9.6*	7.6*	7.6*	5.8	6.4*	–	–	4.2*		4.2*

Stick 2.45 m		Undercarriage stabilized		3.0 m		4.5 m		6.0 m		7.5 m		9.0 m					
		m	m	m	m	m	m	m	m	m	m						
9.0	rear	–	–	–	–	–	–	–	–	–	–	–	–	5.2*	5.2*	4.9	
	front	–	–	–	–	–	–	–	–	–	–	–	–	5.2*	5.2*		
	Blade	–	–	–	–	–	–	–	–	–	–	–	–	5.2*	5.2*		
	Blade	Outriggers	–	–	–	–	–	–	–	–	–	–	–	5.2*	5.2*		
	Outriggers	Blade	–	–	–	–	–	–	–	–	–	–	–	5.2*	5.2*		
7.5	rear	–	–	–	–	–	–	–	–	–	–	–	–	4.1	4.3*	6.7	
	front	–	–	–	–	–	–	–	–	–	–	–	–	4.3*	4.3*		
	Blade	–	–	–	–	–	–	–	–	–	–	–	–	4.3*	4.3*		
	Blade	Outriggers	–	–	–	–	–	–	–	–	–	–	–	4.3*	4.3*		
	Outriggers	Blade	–	–	–	–	–	–	–	–	–	–	–	4.3*	4.3*		
6.0	rear	–	–	–	–	–	–	–	–	–	–	–	–	3.1	4.0*	7.8	
	front	–	–	–	–	–	–	–	–	–	–	–	–	3.4	4.0*		
	Blade	–	–	–	–	–	–	–	–	–	–	–	–	4.0*	4.0*		
	Blade	Outriggers	–	–	–	–	–	–	–	–	–	–	–	4.0*	4.0*		
	Outriggers	Blade	–	–	–	–	–	–	–	–	–	–	–	4.0*	4.0*		
4.5	rear	–	–	11.3*	11.3*	7.5	8.9*	5.0	6.9	3.4	4.9	–	–	2.6	3.9*	8.4	
	front	–	–	11.3*	11.3*	8.1	8.9*	5.3	7.4*	3.7	6.3*	–	–	2.9	3.9*		
	Blade	–	–	11.3*	11.3*	8.9*	8.9*	7.4*	7.4*	5.8	6.3*	–	–	3.9*	3.9*		
	Blade	Outriggers	–	–	11.3*	11.3*	8.9*	8.9*	7.4*	7.4*	5.8	6.3*	–	–	3.9*		3.9*
	Outriggers	Blade	–	–	11.3*	11.3*	8.9*	8.9*	7.4*	7.4*	5.8	6.3*	–	–	3.9*		3.9*
3.0	rear	–	–	12.9	14.3*	7.3	10.2	4.9	6.8	3.4	4.9	–	–	2.4	3.6	8.8	
	front	–	–	14.0	14.3*	7.8	10.9*	5.2	8.1*	3.7	6.6*	–	–	2.6	4.0*		
	Blade	–	–	14.0*	14.0*	11.1*	11.1*	7.9	8.2*	5.8	6.6*	–	–	4.0*	4.0*		
	Blade	Outriggers	–	–	14.0*	14.0*	11.1*	11.1*	7.8	8.2*	5.7	6.6*	–	–	4.0*		4.0*
	Outriggers	Blade	–	–	14.0*	14.0*	11.1*	11.1*	8.2*	8.2*	6.6*	6.6*	–	–	4.0*		4.0*

Height
 Can be slewed through 360°
 In longitudinal position of undercarriage
 Max. reach
 * Limited by hydr. capacity

The lift capacities on the load lift hook of the Liebherr quick coupler SWA 48 without attachment are stated in metric tons (t) and are valid on a firm, level supporting surface with blocked oscillating axle. These capacities can be slewed through 360° with the undercarriage in the transverse position. Capacities in the longitudinal position of the undercarriage (+/– 15°) are specified over the steering axle with the stabilizers raised and over the rigid axle with the stabilizers down. The values apply when the adjusting cylinder is in the optimal position. Indicated loads based on the ISO 10567 standard and do not exceed 75 % of tipping or 87 % of hydraulic capacity, or are limited by the permissible load of the load lift hook on the quick coupler (max. 12 t). Without the quick coupler, lift capacities will increase by up to 226 kg.

In accordance with the harmonised European Standard EN 474-5, hydraulic excavators used for lifting operations must be equipped with pipe fracture safety valves, an overload warning device, a load lift hook and a lift capacity chart.

Backhoe Bucket

with Two-Piece Boom 5.80 m (Standard Counterweight)

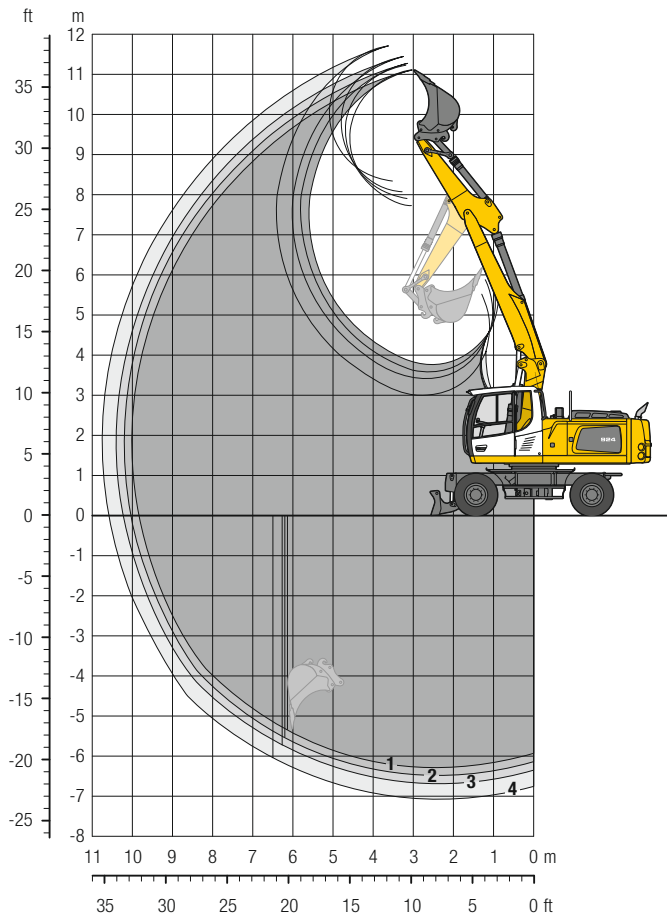

Digging Envelope

with quick coupler		1	2	3	4
Stick length	m	2.25	2.45	2.65	3.05
Max. digging depth	m	6.30	6.50	6.70	7.05
Max. reach at ground level	m	9.85	10.05	10.25	10.60
Max. dumping height	m	7.75	7.90	8.05	8.35
Max. teeth height	m	11.10	11.25	11.45	11.70
Min. equipment radius	m	3.25	3.15	3.10	3.15

Digging Forces

without quick coupler		1	2	3	4
Max. digging force (ISO 6015)	kN	126.9	119.2	112.4	101.1
	t	12.9	12.2	11.5	10.3
Max. breakout force (ISO 6015)	kN	140.6	140.6	140.6	140.6
	t	14.3	14.3	14.3	14.3

Max. breakout force with ripper bucket

186.0 kN (19.0 t)

Operating Weight

The operating weight includes the basic machine with 8 tyres plus intermediate rings, two-piece boom 5.80 m, stick 2.45 m, quick coupler SWA 48 and bucket 1,250 mm/1.15 m³.

Undercarriage versions	Weight (kg)
A 924 Litronic with rear blade	21,600
A 924 Litronic with rear outriggers + front blade	23,300
A 924 Litronic with rear + front outriggers	23,700
A 924 EW Litronic with rear blade	21,700
A 924 EW Litronic with rear outriggers + front blade	23,700
A 924 EW Litronic with rear + front outriggers	24,200

Buckets Machine stability per ISO 10567* (75% of tipping capacity)

Cutting width mm	Capacity ISO 7451 ¹⁾ m ³	Weight kg	Stabilizers raised				Rear blade down				Rear outriggers + front blade down				Rear + front outriggers down			
			Stick length (m)				Stick length (m)				Stick length (m)				Stick length (m)			
			2.25	2.45	2.65	3.05	2.25	2.45	2.65	3.05	2.25	2.45	2.65	3.05	2.25	2.45	2.65	3.05
850 ²⁾	0.75	650	■	△	■	-	■	■	■	△	■	■	■	■	■	■	■	■
1,050 ²⁾	0.95	720	-	-	-	-	△	△	-	-	■	■	■	■	■	■	■	■
1,250 ²⁾	1.15	810	-	-	-	-	-	-	-	-	■	■	■	■	■	■	■	■
1,400 ²⁾	1.35	880	-	-	-	-	-	-	-	-	■	■	■	■	■	■	■	■
1,500 ²⁾	1.45	890	-	-	-	-	-	-	-	-	■	■	■	■	■	■	■	■
850 ³⁾	0.75	690	△	△	■	-	■	■	■	△	■	■	■	■	■	■	■	■
1,050 ³⁾	0.95	800	-	-	-	-	△	△	-	-	■	■	■	■	■	■	■	■
1,250 ³⁾	1.15	910	-	-	-	-	-	-	-	-	■	■	■	■	■	■	■	■
1,400 ³⁾	1.35	960	-	-	-	-	-	-	-	-	■	■	■	■	■	■	■	■
1,500 ³⁾	1.45	1,000	-	-	-	-	-	-	-	-	■	■	■	△	■	■	■	■
850 ⁴⁾	0.80	630	△	△	△	-	■	■	△	△	■	■	■	■	■	■	■	■
1,050 ⁴⁾	1.05	720	-	-	-	-	△	△	-	-	■	■	■	■	■	■	■	■
1,250 ⁴⁾	1.30	800	-	-	-	-	-	-	-	-	■	■	■	■	■	■	■	■
1,400 ⁴⁾	1.50	870	-	-	-	-	-	-	-	-	■	■	■	△	■	■	■	■
1,500 ⁴⁾	1.65	890	-	-	-	-	-	-	-	-	■	■	△	△	■	■	■	■

Buckets Machine stability per ISO 10567* (75% of tipping capacity)

Cutting width mm	Capacity ISO 7451 ¹⁾ m ³	Weight kg	EW Stabilizers raised				EW Rear blade down				EW Rear outriggers + front blade down				EW Rear + front outriggers down			
			Stick length (m)				Stick length (m)				Stick length (m)				Stick length (m)			
			2.25	2.45	2.65	3.05	2.25	2.45	2.65	3.05	2.25	2.45	2.65	3.05	2.25	2.45	2.65	3.05
850 ²⁾	0.75	650	■	■	■	△	■	■	■	■	■	■	■	■	■	■	■	■
1,050 ²⁾	0.95	720	△	△	△	-	■	■	△	△	■	■	■	■	■	■	■	■
1,250 ²⁾	1.15	810	-	-	-	-	△	△	-	-	■	■	■	■	■	■	■	■
1,400 ²⁾	1.35	880	-	-	-	-	-	-	-	-	■	■	■	■	■	■	■	■
1,500 ²⁾	1.45	890	-	-	-	-	-	-	-	-	■	■	■	■	■	■	■	■
850 ³⁾	0.75	690	■	■	■	△	■	■	■	■	■	■	■	■	■	■	■	■
1,050 ³⁾	0.95	800	△	△	-	-	■	△	△	△	■	■	■	■	■	■	■	■
1,250 ³⁾	1.15	910	-	-	-	-	△	-	-	-	■	■	■	■	■	■	■	■
1,400 ³⁾	1.35	960	-	-	-	-	-	-	-	-	■	■	■	■	■	■	■	■
1,500 ³⁾	1.45	1,000	-	-	-	-	-	-	-	-	■	■	■	■	■	■	■	■
850 ⁴⁾	0.80	630	■	■	■	△	■	■	■	■	■	■	■	■	■	■	■	■
1,050 ⁴⁾	1.05	720	△	△	-	-	△	△	△	-	■	■	■	■	■	■	■	■
1,250 ⁴⁾	1.30	800	-	-	-	-	-	-	-	-	■	■	■	■	■	■	■	■
1,400 ⁴⁾	1.50	870	-	-	-	-	-	-	-	-	■	■	■	■	■	■	■	■
1,500 ⁴⁾	1.65	890	-	-	-	-	-	-	-	-	■	■	■	■	■	■	■	■

* Indicated loads are based on ISO 10567 and do not exceed 75% of tipping or 87% of hydraulic capacity, max. stick length without quick coupler, lifted 360° on firm with blocked oscillating axle

¹⁾ comparable with SAE (heaped)

²⁾ Bucket with teeth ³⁾ Bucket with teeth in HD-version ⁴⁾ Bucket with cutting edge (also available in HD-version)

Max. material weight ■ = ≤ 1.8 t/m³, ■ = ≤ 1.5 t/m³, △ = ≤ 1.2 t/m³, - = not authorised

Backhoe Bucket

with Mono Boom 5.65 m (Heavy Counterweight)

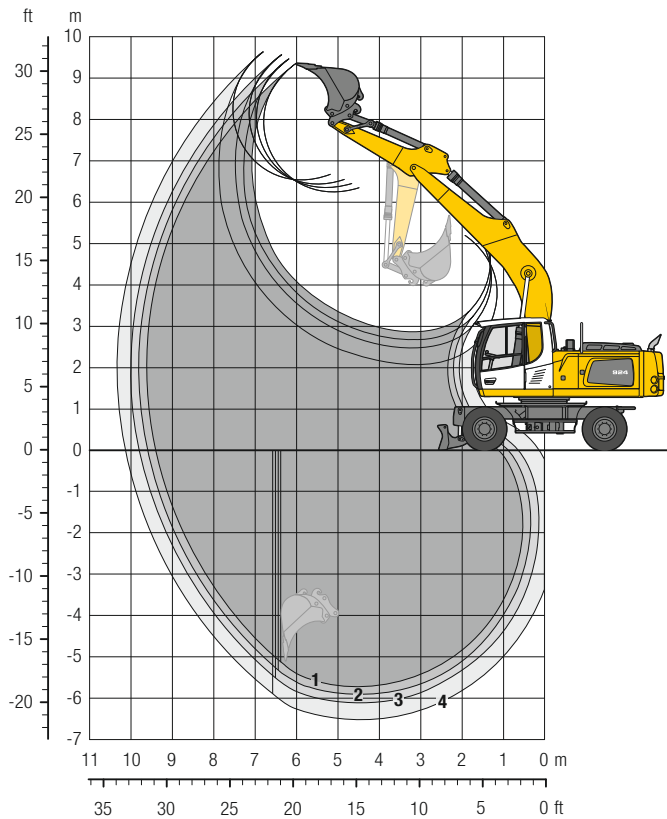

Digging Envelope

with quick coupler		1	2	3	4
Stick length	m	2.25	2.45	2.65	3.05
Max. digging depth	m	5.70	5.90	6.10	6.50
Max. reach at ground level	m	9.40	9.60	9.80	10.15
Max. dumping height	m	6.35	6.45	6.55	6.70
Max. teeth height	m	9.35	9.45	9.55	9.65
Min. equipment radius	m	3.90	3.70	3.45	3.15

Digging Forces

without quick coupler		1	2	3	4
Max. digging force (ISO 6015)	kN	126.9	119.2	112.4	101.1
	t	12.9	12.2	11.5	10.3
Max. breakout force (ISO 6015)	kN	140.6	140.6	140.6	140.6
	t	14.3	14.3	14.3	14.3

Max. breakout force with ripper bucket

186.0 kN (19.0 t)

Operating Weight

The operating weight includes the basic machine with 8 tyres plus intermediate rings, mono boom 5.65 m, stick 2.45 m, quick coupler SWA 48 and bucket 1,250 mm/1.15 m³.

Undercarriage versions	Weight (kg)
A 924 Litronic with rear blade	23,300
A 924 Litronic with rear blade + front outriggers	25,100
A 924 Litronic with rear outriggers + front blade	24,900
A 924 Litronic with rear + front outriggers	25,200
A 924 EW Litronic with rear blade	23,400
A 924 EW Litronic with rear blade + front outriggers	25,500
A 924 EW Litronic with rear outriggers + front blade	25,300
A 924 EW Litronic with rear + front outriggers	25,800

Buckets Machine stability per ISO 10567* (75% of tipping capacity)

Cutting width mm	Capacity ISO 7451 ¹⁾ m ³	Weight kg	Stabilizers raised				Rear blade down				Rear blade + front outriggers down				Rear outriggers + front blade down				Rear + front outriggers down			
			Stick length (m)				Stick length (m)				Stick length (m)				Stick length (m)				Stick length (m)			
			2.25	2.45	2.65	3.05	2.25	2.45	2.65	3.05	2.25	2.45	2.65	3.05	2.25	2.45	2.65	3.05	2.25	2.45	2.65	3.05
850 ²⁾	0.75	650	■	■	■	■	■	■	■	■	■	■	■	■	■	■	■	■	■	■	■	■
1,050 ²⁾	0.95	720	■	■	■	■	■	■	■	■	■	■	■	■	■	■	■	■	■	■	■	■
1,250 ²⁾	1.15	810	■	■	■	△	■	■	■	■	■	■	■	■	■	■	■	■	■	■	■	■
1,400 ²⁾	1.35	880	△	△	△	-	■	■	△	△	■	■	■	■	■	■	■	■	■	■	■	■
1,500 ²⁾	1.45	890	△	△	-	-	■	△	△	△	■	■	■	■	■	■	■	■	■	■	■	■
850 ³⁾	0.75	690	■	■	■	■	■	■	■	■	■	■	■	■	■	■	■	■	■	■	■	■
1,050 ³⁾	0.95	800	■	■	■	■	■	■	■	■	■	■	■	■	■	■	■	■	■	■	■	■
1,250 ³⁾	1.15	910	■	■	△	△	■	■	■	■	■	■	■	■	■	■	■	■	■	■	■	■
1,400 ³⁾	1.35	960	△	△	△	-	■	△	△	△	■	■	■	■	■	■	■	■	■	■	■	■
1,500 ³⁾	1.45	1,000	△	△	-	-	△	△	△	-	■	■	■	■	■	■	■	■	■	■	■	■
850 ⁴⁾	0.80	630	■	■	■	■	■	■	■	■	■	■	■	■	■	■	■	■	■	■	■	■
1,050 ⁴⁾	1.05	720	■	■	■	■	■	■	■	■	■	■	■	■	■	■	■	■	■	■	■	■
1,250 ⁴⁾	1.30	800	■	△	△	△	■	■	■	△	■	■	■	■	■	■	■	■	■	■	■	■
1,400 ⁴⁾	1.50	870	△	△	-	-	△	△	△	-	■	■	■	■	■	■	■	■	■	■	■	■
1,500 ⁴⁾	1.65	890	-	-	-	-	△	△	-	-	■	■	■	■	■	■	■	■	■	■	■	■

Buckets Machine stability per ISO 10567* (75% of tipping capacity)

Cutting width mm	Capacity ISO 7451 ¹⁾ m ³	Weight kg	EW Stabilizers raised				EW Rear blade down				EW Rear blade + front outriggers down				EW Rear outriggers + front blade down				EW Rear + front outriggers down			
			Stick length (m)				Stick length (m)				Stick length (m)				Stick length (m)				Stick length (m)			
			2.25	2.45	2.65	3.05	2.25	2.45	2.65	3.05	2.25	2.45	2.65	3.05	2.25	2.45	2.65	3.05	2.25	2.45	2.65	3.05
850 ²⁾	0.75	650	■	■	■	■	■	■	■	■	■	■	■	■	■	■	■	■	■	■	■	■
1,050 ²⁾	0.95	720	■	■	■	■	■	■	■	■	■	■	■	■	■	■	■	■	■	■	■	■
1,250 ²⁾	1.15	810	■	■	■	■	■	■	■	■	■	■	■	■	■	■	■	■	■	■	■	■
1,400 ²⁾	1.35	880	■	■	△	△	■	■	■	■	■	■	■	■	■	■	■	■	■	■	■	■
1,500 ²⁾	1.45	890	■	△	△	△	■	■	△	△	■	■	■	■	■	■	■	■	■	■	■	■
850 ³⁾	0.75	690	■	■	■	■	■	■	■	■	■	■	■	■	■	■	■	■	■	■	■	■
1,050 ³⁾	0.95	800	■	■	■	■	■	■	■	■	■	■	■	■	■	■	■	■	■	■	■	■
1,250 ³⁾	1.15	910	■	■	■	■	■	■	■	■	■	■	■	■	■	■	■	■	■	■	■	■
1,400 ³⁾	1.35	960	■	■	△	△	■	■	■	△	■	■	■	■	■	■	■	■	■	■	■	■
1,500 ³⁾	1.45	1,000	△	△	△	-	■	■	△	△	■	■	■	■	■	■	■	■	■	■	■	■
850 ⁴⁾	0.80	630	■	■	■	■	■	■	■	■	■	■	■	■	■	■	■	■	■	■	■	■
1,050 ⁴⁾	1.05	720	■	■	■	■	■	■	■	■	■	■	■	■	■	■	■	■	■	■	■	■
1,250 ⁴⁾	1.30	800	■	■	■	△	■	■	■	■	■	■	■	■	■	■	■	■	■	■	■	■
1,400 ⁴⁾	1.50	870	△	△	△	△	■	■	■	△	■	■	■	■	■	■	■	■	■	■	■	■
1,500 ⁴⁾	1.65	890	△	△	△	-	■	△	△	△	■	■	■	■	■	■	■	■	■	■	■	■

* Indicated loads are based on ISO 10567 and do not exceed 75% of tipping or 87% of hydraulic capacity, max. stick length without quick coupler, lifted 360° on firm with blocked oscillating axle

¹⁾ comparable with SAE (heaped)

²⁾ Bucket with teeth ³⁾ Bucket with teeth in HD-version ⁴⁾ Bucket with cutting edge (also available in HD-version)

Max. material weight ■ = ≤ 1.8 t/m³, ■ = ≤ 1.5 t/m³, △ = ≤ 1.2 t/m³, - = not authorised

Lift Capacities

with Mono Boom 5.65 m (Heavy Counterweight)

		Stick 2.25 m							Stick 2.45 m		
m		3.0 m	4.5 m	6.0 m	7.5 m	9.0 m	9.0 m	9.0 m	m		
9.0	Blade								4.4*	4.4*	
	Blade								4.4*	4.4*	
7.5	Blade								4.4*	4.4*	
	Blade								4.4*	4.4*	
6.0	Blade			4.5	6.4*				3.3	4.2*	
	Blade			4.8	6.4*				3.6	4.2*	
4.5	Blade			4.2	6.8	2.9	4.7		2.7	4.2*	
	Blade			4.6	7.1*	3.2	5.6*		3.0	4.2*	
3.0	Blade			7.1*	7.1*	5.1	5.6*		4.2*	4.2*	
	Blade			7.1*	7.1*	5.1	5.6*		4.2*	4.2*	
1.5	Blade			5.3	9.3	3.7	6.1	2.7	4.4		
	Blade			5.9	12.5*	4.0	9.1*	2.9	7.4*		
0	Blade			10.2	12.5*	6.6	9.0*	4.8	7.3*		
	Blade			10.1	12.5*	6.6	9.0*	4.8	7.3*		
-1.5	Blade			6.1*	6.1*	5.1	9.0	3.5	5.9	2.6	4.3
	Blade			6.1*	6.1*	5.6	13.3*	3.8	9.6*	2.8	7.6*
-3.0	Blade			6.1*	6.1*	9.8	13.2*	6.4	9.6*	4.7	7.6*
	Blade			6.1*	6.1*	9.7	13.2*	6.4	9.6*	4.7	7.6*
-4.5	Blade			9.2	11.0*	5.0	8.9	3.4	5.8		
	Blade			10.2	11.0*	5.5	13.0*	3.7	9.6*		
9.0	Blade			11.0*	11.0*	9.7	12.9*	6.3	9.5*		
	Blade			11.0*	11.0*	9.6	12.9*	6.3	9.5*		
7.5	Blade			11.0*	11.0*	12.7	12.9*	8.0	9.5*		
	Blade			9.4	16.3*	5.1	9.0	3.5	5.9		
6.0	Blade			10.4	16.3*	5.6	11.7*	3.8	8.6*		
	Blade			16.1*	16.1*	9.8	11.6*	6.4	8.5*		
4.5	Blade			16.1*	16.1*	9.8	11.6*	6.4	8.5*		
	Blade			16.1*	16.1*	11.6*	11.6*	8.1	8.5*		
3.0	Blade			5.4	8.5*				5.0	8.0*	
	Blade			5.9	8.5*				5.5	8.0*	
1.5	Blade			8.5*	8.5*				7.9*	7.9*	
	Blade			8.5*	8.5*				7.9*	7.9*	
0	Blade			8.5*	8.5*				7.9*	7.9*	
	Blade			8.5*	8.5*				7.9*	7.9*	

		Stick 2.45 m							Stick 2.65 m		
m		3.0 m	4.5 m	6.0 m	7.5 m	9.0 m	9.0 m	9.0 m	m		
9.0	Blade								4.1*	4.1*	
	Blade								4.1*	4.1*	
7.5	Blade								4.1*	4.1*	
	Blade								4.1*	4.1*	
6.0	Blade			4.5	6.2*				3.1	3.9*	
	Blade			4.8*	6.2*				3.4	3.9*	
4.5	Blade			4.2	6.2*				3.9*	3.9*	
	Blade			4.2	6.2*				3.9*	3.9*	
3.0	Blade			4.3	6.8	2.9	4.7		2.6	3.9*	
	Blade			4.6	6.9*	3.2	5.8*		2.9	3.9*	
1.5	Blade			6.8*	6.8*	5.1	5.8*		3.9*	3.9*	
	Blade			6.8*	6.8*	5.1	5.8*		3.9*	3.9*	
0	Blade			5.9	10.0	3.9	6.5	2.8	4.6		
	Blade			6.5	10.3*	4.3	7.9*	3.1	6.8*		
-1.5	Blade			10.3*	10.3*	7.0	7.9*	5.0	6.7*		
	Blade			10.3*	10.3*	6.9	7.9*	4.9	6.7*		
-3.0	Blade			10.3*	10.3*	7.9*	7.9*	6.1	6.7*		
	Blade			5.3	9.3	3.6	6.1	2.6	4.4		
-4.5	Blade			5.9	12.3*	4.0	8.9*	2.9	7.2*		
	Blade			10.2	12.2*	6.6	8.9*	4.8	7.2*		
9.0	Blade			10.1	12.2*	6.6	8.9*	4.8	7.2*		
	Blade			12.2*	12.2*	8.4	8.9*	6.0	7.2*		
7.5	Blade			6.3*	6.3*	5.0	9.0	3.4	5.9	2.5	4.3
	Blade			6.3*	6.3*	5.6	13.2*	3.8	9.5*	2.8	7.5*
6.0	Blade			6.3*	6.3*	9.8	13.1*	6.4	9.5*	4.7	7.5*
	Blade			6.3*	6.3*	9.7	13.1*	6.3	9.5*	4.6	7.5*
4.5	Blade			6.3*	6.3*	12.8	13.1*	8.1	9.5*	5.8	7.5*
	Blade			9.0	10.5*	4.9	8.9	3.3	5.8	2.5	4.3
3.0	Blade			10.1	10.5*	5.5	13.0*	3.7	9.6*	2.7	7.4*
	Blade			10.5*	10.5*	9.7	12.9*	6.3	9.5*	4.6	7.3*
1.5	Blade			10.5*	10.5*	9.6	12.9*	6.2	9.5*	4.6	7.3*
	Blade			10.5*	10.5*	12.7	12.9*	8.0	9.5*	5.8	7.3*
0	Blade			9.2	16.3*	5.0	8.9	3.4	5.8		
	Blade			10.3	16.3*	5.5	11.9*	3.7	8.8*		
-1.5	Blade			16.3*	16.3*	9.7	11.8*	6.3	8.7*		
	Blade			16.3*	16.3*	9.7	11.8*	6.3	8.7*		
-3.0	Blade			16.3*	16.3*	11.8*	11.8*	8.0	8.7*		
	Blade			16.3*	16.3*	11.8*	11.8*	8.0	8.7*		
-4.5	Blade			5.3	9.1*				4.4	7.5	
	Blade			5.5	8.0*				4.8	7.6*	
9.0	Blade			9.0*	9.0*				7.5*	7.5*	
	Blade			9.0*	9.0*				7.5*	7.5*	
7.5	Blade			9.0*	9.0*				7.5*	7.5*	
	Blade			9.0*	9.0*				7.5*	7.5*	
6.0	Blade			9.0*	9.0*				7.5*	7.5*	
	Blade			9.0*	9.0*				7.5*	7.5*	
4.5	Blade			9.0*	9.0*				7.5*	7.5*	
	Blade			9.0*	9.0*				7.5*	7.5*	
3.0	Blade			9.0*	9.0*				7.5*	7.5*	
	Blade			9.0*	9.0*				7.5*	7.5*	

 Height
  Can be slewed through 360°
  In longitudinal position of undercarriage
  Max. reach * Limited by hydr. capacity

The lift capacities on the load lift hook of the Liebherr quick coupler SWA 48 without attachment are stated in metric tons (t) and are valid on a firm, level supporting surface with blocked oscillating axle. These capacities can be slewed through 360° with the undercarriage in the transverse position. Capacities in the longitudinal position of the undercarriage (+/- 15°) are specified over the steering axle with the stabilizers raised and over the rigid axle with the stabilizers down. Indicated loads based on the ISO 10567 standard and do not exceed 75% of tipping or 87% of hydraulic capacity, or are limited by the permissible load of the load lift hook on the quick coupler (max. 12 t). Without the quick coupler, lift capacities will increase by up to 226 kg.

In accordance with the harmonised European Standard EN 474-5, hydraulic excavators used for lifting operations must be equipped with pipe fracture safety valves, an overload warning device, a load lift hook and a lift capacity chart.

Stick 2.65 m

m	Undercarriage stabilized		3.0 m		4.5 m		6.0 m		7.5 m		9.0 m		m
	rear	front	rear	front	rear	front	rear	front	rear	front	rear	front	
9.0	—	—											
	Blade	—											
	Blade	Outriggers											
	Outriggers	Blade											
7.5	—	—											
	Blade	—											
	Blade	Outriggers											
	Outriggers	Blade											
6.0	—	—											
	Blade	—											
	Blade	Outriggers											
	Outriggers	Blade											
4.5	—	—											
	Blade	—											
	Blade	Outriggers											
	Outriggers	Blade											
3.0	—	—											
	Blade	—											
	Blade	Outriggers											
	Outriggers	Blade											
1.5	—	—											
	Blade	—											
	Blade	Outriggers											
	Outriggers	Blade											
0	—	—											
	Blade	—											
	Blade	Outriggers											
	Outriggers	Blade											
-1.5	—	—											
	Blade	—											
	Blade	Outriggers											
	Outriggers	Blade											
-3.0	—	—											
	Blade	—											
	Blade	Outriggers											
	Outriggers	Blade											
-4.5	—	—											
	Blade	—											
	Blade	Outriggers											
	Outriggers	Blade											

Stick 3.05 m

m	Undercarriage stabilized		3.0 m		4.5 m		6.0 m		7.5 m		9.0 m		m
	rear	front	rear	front	rear	front	rear	front	rear	front	rear	front	
9.0	—	—											
	Blade	—											
	Blade	Outriggers											
	Outriggers	Blade											
7.5	—	—											
	Blade	—											
	Blade	Outriggers											
	Outriggers	Blade											
6.0	—	—											
	Blade	—											
	Blade	Outriggers											
	Outriggers	Blade											
4.5	—	—											
	Blade	—											
	Blade	Outriggers											
	Outriggers	Blade											
3.0	—	—											
	Blade	—											
	Blade	Outriggers											
	Outriggers	Blade											
1.5	—	—											
	Blade	—											
	Blade	Outriggers											
	Outriggers	Blade											
0	—	—											
	Blade	—											
	Blade	Outriggers											
	Outriggers	Blade											
-1.5	—	—											
	Blade	—											
	Blade	Outriggers											
	Outriggers	Blade											
-3.0	—	—											
	Blade	—											
	Blade	Outriggers											
	Outriggers	Blade											
-4.5	—	—											
	Blade	—											
	Blade	Outriggers											
	Outriggers	Blade											

Height Can be slewed through 360° In longitudinal position of undercarriage Max. reach * Limited by hydr. capacity

The lift capacities on the load lift hook of the Liebherr quick coupler SWA 48 without attachment are stated in metric tons (t) and are valid on a firm, level supporting surface with blocked oscillating axle. These capacities can be slewed through 360° with the undercarriage in the transverse position. Capacities in the longitudinal position of the undercarriage (+/- 15°) are specified over the steering axle with the stabilizers raised and over the rigid axle with the stabilizers down. Indicated loads based on the ISO 10567 standard and do not exceed 75% of tipping or 87% of hydraulic capacity, or are limited by the permissible load of the load lift hook on the quick coupler (max. 12 t). Without the quick coupler, lift capacities will increase by up to 226 kg. In accordance with the harmonised European Standard EN 474-5, hydraulic excavators used for lifting operations must be equipped with pipe fracture safety valves, an overload warning device, a load lift hook and a lift capacity chart.

Lift Capacities

with Mono Boom 5.65 m (Heavy Counterweight), EW-Undercarriage

Stick 2.25 m		Undercarriage stabilized		3.0 m	4.5 m	6.0 m	7.5 m	9.0 m	m	
m	rear	front	m		m		m		m	
	9.0	—	—							
Blade		—								
Blade		Outriggers								
Outriggers		Blade								
7.5	—	—							4.4*	4.4*
	Blade	—							4.4*	4.4*
	Blade	Outriggers							4.4*	4.4*
	Outriggers	Blade							4.4*	4.4*
6.0	—	—							3.7	4.2*
	Blade	—			4.9	6.4*			4.0	4.2*
	Blade	Outriggers			6.4*	6.4*			4.2*	4.2*
	Outriggers	Blade			6.4*	6.4*			4.2*	4.2*
4.5	—	—							4.2*	4.2*
	Blade	—			4.7	6.8	3.3	4.8	3.1	4.2*
	Blade	Outriggers			5.1	7.1*	3.5	5.6*	3.3	4.2*
	Outriggers	Blade			7.1*	7.1*	5.6*	5.6*	4.2*	4.2*
3.0	—	—							2.7	4.1
	Blade	—			6.6	10.0	4.4	6.5	3.1	4.6
	Blade	Outriggers			10.6*	10.6*	7.7	8.1*	5.5	6.9*
	Outriggers	Blade			10.6*	10.6*	7.7	8.1*	5.5	6.9*
1.5	—	—							2.6	3.9
	Blade	—			6.0	9.4	4.1	6.2	3.0	4.5
	Blade	Outriggers			6.6	12.5*	4.5	9.1*	3.2	7.4*
	Outriggers	Blade			11.4	12.5*	7.4	9.0*	5.3	7.3*
0	—	—							4.7	4.8*
	Blade	—			12.5*	12.5*	9.0*	9.0*	6.7	7.3*
	Blade	Outriggers			6.1*	6.1*	5.7	9.1	3.9	6.0
	Outriggers	Blade			6.1*	6.1*	11.1	13.2*	7.2	9.6*
-1.5	—	—							2.9	5.6*
	Blade	—			6.1*	6.1*	11.1	13.2*	7.1	9.6*
	Blade	Outriggers			6.1*	6.1*	11.1	13.2*	7.1	9.6*
	Outriggers	Blade			6.1*	6.1*	13.2*	13.2*	9.1	9.6*
-3.0	—	—							2.9	4.4
	Blade	—			10.6	11.0*	5.7	9.0	3.8	5.9
	Blade	Outriggers			11.0*	11.0*	6.2	13.0*	4.2	9.6*
	Outriggers	Blade			11.0*	11.0*	11.0	12.9*	7.1	9.5*
-4.5	—	—							5.2	7.0*
	Blade	—			11.0*	11.0*	10.9	12.9*	7.0	9.5*
	Blade	Outriggers			11.0*	11.0*	12.9*	12.9*	9.0	9.5*
	Outriggers	Blade			10.8	16.3*	5.8	9.1	3.9	6.0
-4.5	—	—							3.6	5.4
	Blade	—			12.0	16.3*	6.3	11.7*	4.2	8.6*
	Blade	Outriggers			16.1*	16.1*	11.1	11.6*	7.1	8.5*
	Outriggers	Blade			16.1*	16.1*	11.0	11.6*	7.1	8.5*

Stick 2.45 m		Undercarriage stabilized		3.0 m	4.5 m	6.0 m	7.5 m	9.0 m	m		
m	rear	front	m		m		m		m		
	9.0	—	—								
Blade		—									
Blade		Outriggers									
Outriggers		Blade									
7.5	—	—							4.1*	4.1*	
	Blade	—				4.8*	4.8*		4.1*	4.1*	
	Blade	Outriggers				4.8*	4.8*		4.1*	4.1*	
	Outriggers	Blade				4.8*	4.8*		4.1*	4.1*	
6.0	—	—							3.5	3.9*	
	Blade	—				4.9	6.2*		3.8	3.9*	
	Blade	Outriggers				6.2*	6.2*		3.9*	3.9*	
	Outriggers	Blade				6.2*	6.2*		3.9*	3.9*	
4.5	—	—							2.9	3.9*	
	Blade	—				4.7	6.9	3.3	4.8	3.2	3.9*
	Blade	Outriggers				5.1	6.9*	3.5	5.8*	3.9*	3.9*
	Outriggers	Blade				7.1*	7.1*	5.6*	5.8*	3.9*	3.9*
3.0	—	—							2.6	3.9	
	Blade	—			6.6	10.1	4.4	6.5	3.1	4.6	
	Blade	Outriggers			10.3*	10.3*	7.8	7.9*	5.5	6.7*	
	Outriggers	Blade			10.3*	10.3*	7.7	7.9*	5.5	6.7*	
1.5	—	—							2.5	3.8	
	Blade	—			6.0	9.4	4.1	6.2	3.0	4.5	
	Blade	Outriggers			6.6	12.3*	4.4	8.9*	3.2	7.2*	
	Outriggers	Blade			11.5	12.2*	7.4	8.9*	5.3	7.2*	
0	—	—							4.4*	4.4*	
	Blade	—			12.2*	12.2*	8.9*	8.9*	6.7	7.2*	
	Blade	Outriggers			6.3*	6.3*	5.7	9.0	3.9	5.9	
	Outriggers	Blade			6.3*	6.3*	11.0	13.1*	7.1	9.5*	
-1.5	—	—							2.8	5.0*	
	Blade	—			6.3*	6.3*	11.0	13.1*	7.1	9.5*	
	Blade	Outriggers			6.3*	6.3*	13.1*	13.1*	9.1	9.5*	
	Outriggers	Blade			6.3*	6.3*	13.1*	13.1*	9.1	9.5*	
-3.0	—	—							2.8	4.2	
	Blade	—			10.4	10.5*	5.6	8.9	3.8	5.8	
	Blade	Outriggers			10.5*	10.5*	6.2	13.0*	4.1	9.6*	
	Outriggers	Blade			10.5*	10.5*	10.9	12.9*	7.0	9.5*	
-4.5	—	—							5.0	6.2*	
	Blade	—			10.5*	10.5*	10.9	12.9*	7.0	9.5*	
	Blade	Outriggers			10.5*	10.5*	12.9*	12.9*	9.0	9.5*	
	Outriggers	Blade			10.6	16.3*	5.7	9.0	3.8	5.9	
-4.5	—	—							3.3	5.1	
	Blade	—			11.8	16.3*	6.2	11.9*	4.2	8.8*	
	Blade	Outriggers			16.3*	16.3*	11.0	11.8*	7.1	8.7*	
	Outriggers	Blade			16.3*	16.3*	10.9	11.8*	7.0	8.7*	

 **Height**
 **Can be slewed through 360°**
 **In longitudinal position of undercarriage**
 **Max. reach**
 * Limited by hydr. capacity

The lift capacities on the load lift hook of the Liebherr quick coupler SWA 48 without attachment are stated in metric tons (t) and are valid on a firm, level supporting surface with blocked oscillating axle. These capacities can be slewed through 360° with the undercarriage in the transverse position. Capacities in the longitudinal position of the undercarriage (+/- 15°) are specified over the steering axle with the stabilizers raised and over the rigid axle with the stabilizers down. Indicated loads based on the ISO 10567 standard and do not exceed 75% of tipping or 87% of hydraulic capacity, or are limited by the permissible load of the load lift hook on the quick coupler (max. 12 t). Without the quick coupler, lift capacities will increase by up to 226 kg. In accordance with the harmonised European Standard EN 474-5, hydraulic excavators used for lifting operations must be equipped with pipe fracture safety valves, an overload warning device, a load lift hook and a lift capacity chart.

Stick 2.65 m

Undercarriage stabilized		3.0 m		4.5 m		6.0 m		7.5 m		9.0 m		m	
m	rear	front											m
9.0	Blade	—											
	Blade	—											
	Outriggers	Blade											
	Outriggers	Outriggers											
7.5	Blade	—										3.8*	3.8*
	Blade	—										3.8*	3.8*
	Outriggers	Blade										3.8*	3.8*
	Outriggers	Outriggers										3.8*	3.8*
6.0	Blade	—											
	Blade	—											
	Outriggers	Blade											
	Outriggers	Outriggers											
4.5	Blade	—											
	Blade	—											
	Outriggers	Blade											
	Outriggers	Outriggers											
3.0	Blade	—											
	Blade	—											
	Outriggers	Blade											
	Outriggers	Outriggers											
1.5	Blade	—											
	Blade	—											
	Outriggers	Blade											
	Outriggers	Outriggers											
0	Blade	—											
	Blade	—											
	Outriggers	Blade											
	Outriggers	Outriggers											
-1.5	Blade	—											
	Blade	—											
	Outriggers	Blade											
	Outriggers	Outriggers											
-3.0	Blade	—											
	Blade	—											
	Outriggers	Blade											
	Outriggers	Outriggers											
-4.5	Blade	—											
	Blade	—											
	Outriggers	Blade											
	Outriggers	Outriggers											

Stick 3.05 m

Undercarriage stabilized		3.0 m		4.5 m		6.0 m		7.5 m		9.0 m		m	
m	rear	front											m
9.0	Blade	—											
	Blade	—											
	Outriggers	Blade											
	Outriggers	Outriggers											
7.5	Blade	—											
	Blade	—											
	Outriggers	Blade											
	Outriggers	Outriggers											
6.0	Blade	—											
	Blade	—											
	Outriggers	Blade											
	Outriggers	Outriggers											
4.5	Blade	—											
	Blade	—											
	Outriggers	Blade											
	Outriggers	Outriggers											
3.0	Blade	—											
	Blade	—											
	Outriggers	Blade											
	Outriggers	Outriggers											
1.5	Blade	—											
	Blade	—											
	Outriggers	Blade											
	Outriggers	Outriggers											
0	Blade	—											
	Blade	—											
	Outriggers	Blade											
	Outriggers	Outriggers											
-1.5	Blade	—											
	Blade	—											
	Outriggers	Blade											
	Outriggers	Outriggers											
-3.0	Blade	—											
	Blade	—											
	Outriggers	Blade											
	Outriggers	Outriggers											
-4.5	Blade	—											
	Blade	—											
	Outriggers	Blade											
	Outriggers	Outriggers											

 Height  Can be slewed through 360°  In longitudinal position of undercarriage  Max. reach * Limited by hydr. capacity

The lift capacities on the load lift hook of the Liebherr quick coupler SWA 48 without attachment are stated in metric tons (t) and are valid on a firm, level supporting surface with blocked oscillating axle. These capacities can be slewed through 360° with the undercarriage in the transverse position. Capacities in the longitudinal position of the undercarriage (+/- 15°) are specified over the steering axle with the stabilizers raised and over the rigid axle with the stabilizers down. Indicated loads based on the ISO 10567 standard and do not exceed 75% of tipping or 87% of hydraulic capacity, or are limited by the permissible load of the load lift hook on the quick coupler (max. 12 t). Without the quick coupler, lift capacities will increase by up to 226 kg.

In accordance with the harmonised European Standard EN 474-5, hydraulic excavators used for lifting operations must be equipped with pipe fracture safety valves, an overload warning device, a load lift hook and a lift capacity chart.

Clamshell Grab

with Two-Piece Boom 5.80 m (Heavy Counterweight)

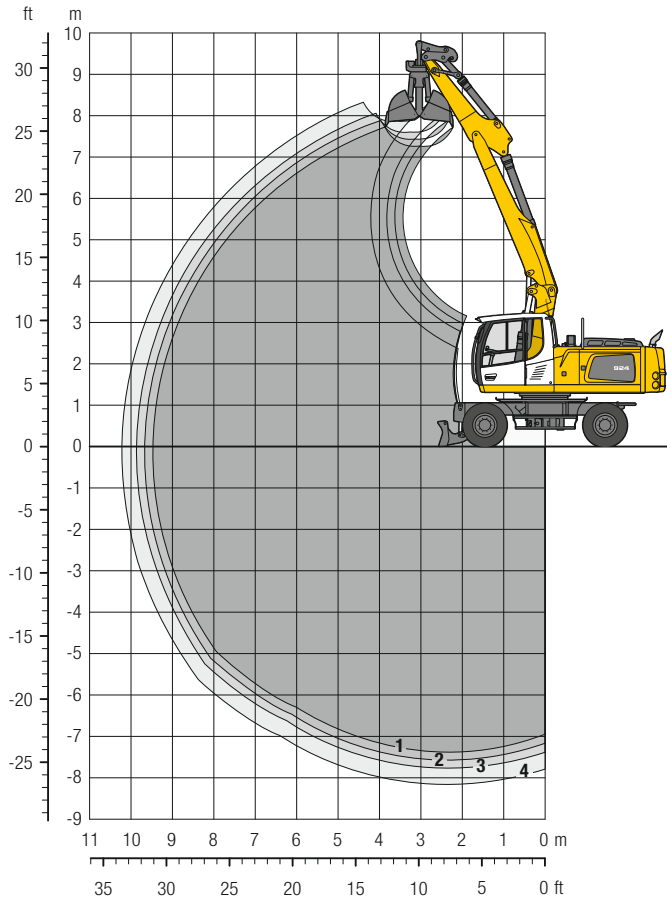

Digging Envelope

with quick coupler	1	2	3	4
Stick length	m 2.25	2.45	2.65	3.05
Max. digging depth	m 7.35	7.55	7.75	8.15
Max. reach at ground level	m 9.50	9.65	9.85	10.25
Max. dumping height	m 7.30	7.45	7.60	7.90

Clamshell Grab GM 10B

Max. tooth force	73 kN (7.4 t)
Max. torque of hydr. swivel	1.76 kNm

Operating Weight

The operating weight includes the basic machine with 8 tyres plus intermediate rings, two-piece boom 5.80 m, stick 2.45 m, quick coupler SWA 48 and clamshell grab GM 10B/1.00 m³ (1,000 mm without ejector).

Undercarriage versions	Weight (kg)
A 924 Litronic with rear blade	24,000
A 924 Litronic with rear blade + front outriggers	25,900
A 924 Litronic with rear outriggers + front blade	25,700
A 924 Litronic with rear + front outriggers	26,000
A 924 EW Litronic with rear blade	24,100
A 924 EW Litronic with rear blade + front outriggers	26,300
A 924 EW Litronic with rear outriggers + front blade	26,100
A 924 EW Litronic with rear + front outriggers	26,500

Clamshell Grab GM 10B Machine stability per ISO 10567* (75% of tipping capacity)

Width of clamshells mm	Capacity m³	Weight kg	Stabilizers raised				Rear blade down				Rear blade + front outriggers down				Rear outriggers + front blade down				Rear + front outriggers down			
			Stick length (m)				Stick length (m)				Stick length (m)				Stick length (m)				Stick length (m)			
			2.25	2.45	2.65	3.05	2.25	2.45	2.65	3.05	2.25	2.45	2.65	3.05	2.25	2.45	2.65	3.05	2.25	2.45	2.65	3.05
320 ¹⁾	0.17	770	■	■	■	■	■	■	■	■	■	■	■	■	■	■	■	■	■	■	■	■
400 ¹⁾	0.22	820	■	■	■	■	■	■	■	■	■	■	■	■	■	■	■	■	■	■	■	■
600 ¹⁾	0.35	860	■	■	■	■	■	■	■	■	■	■	■	■	■	■	■	■	■	■	■	■
800 ¹⁾	0.45	910	■	■	■	■	■	■	■	■	■	■	■	■	■	■	■	■	■	■	■	■
1,000 ¹⁾	0.60	970	■	■	■	■	■	■	■	■	■	■	■	■	■	■	■	■	■	■	■	■
1,000 ¹⁾³⁾	1.00	1,040	■	■	■	△	■	■	■	△	■	■	■	■	■	■	■	■	■	■	■	■
1,500 ¹⁾³⁾	1.50	1,160	-	-	-	-	△	-	-	-	-	-	-	■	■	■	■	■	■	■	■	■
1,800 ¹⁾³⁾	1.80	1,280	-	-	-	-	-	-	-	-	-	-	-	■	■	■	■	■	■	■	■	■
320 ²⁾	0.17	820	■	■	■	■	■	■	■	■	■	■	■	■	■	■	■	■	■	■	■	■
400 ²⁾	0.22	880	■	■	■	■	■	■	■	■	■	■	■	■	■	■	■	■	■	■	■	■
600 ²⁾	0.30	950	■	■	■	■	■	■	■	■	■	■	■	■	■	■	■	■	■	■	■	■
800 ²⁾	0.45	1,010	■	■	■	■	■	■	■	■	■	■	■	■	■	■	■	■	■	■	■	■

Clamshell Grab GM 10B Machine stability per ISO 10567* (75% of tipping capacity)

Width of clamshells mm	Capacity m³	Weight kg	EW Stabilizers raised				EW Rear blade down				EW Rear blade + front outriggers down				EW Rear outriggers + front blade down				EW Rear + front outriggers down			
			Stick length (m)				Stick length (m)				Stick length (m)				Stick length (m)				Stick length (m)			
			2.25	2.45	2.65	3.05	2.25	2.45	2.65	3.05	2.25	2.45	2.65	3.05	2.25	2.45	2.65	3.05	2.25	2.45	2.65	3.05
320 ¹⁾	0.17	770	■	■	■	■	■	■	■	■	■	■	■	■	■	■	■	■	■	■	■	■
400 ¹⁾	0.22	820	■	■	■	■	■	■	■	■	■	■	■	■	■	■	■	■	■	■	■	■
600 ¹⁾	0.35	860	■	■	■	■	■	■	■	■	■	■	■	■	■	■	■	■	■	■	■	■
800 ¹⁾	0.45	910	■	■	■	■	■	■	■	■	■	■	■	■	■	■	■	■	■	■	■	■
1,000 ¹⁾	0.60	970	■	■	■	■	■	■	■	■	■	■	■	■	■	■	■	■	■	■	■	■
1,000 ¹⁾³⁾	1.00	1,040	■	■	■	■	■	■	■	■	■	■	■	■	■	■	■	■	■	■	■	■
1,500 ¹⁾³⁾	1.50	1,160	△	-	-	-	△	△	△	-	-	-	-	■	■	■	■	■	■	■	■	■
1,800 ¹⁾³⁾	1.80	1,280	-	-	-	-	-	-	-	-	-	-	-	■	■	■	■	■	■	■	■	■
320 ²⁾	0.17	820	■	■	■	■	■	■	■	■	■	■	■	■	■	■	■	■	■	■	■	■
400 ²⁾	0.22	880	■	■	■	■	■	■	■	■	■	■	■	■	■	■	■	■	■	■	■	■
600 ²⁾	0.30	950	■	■	■	■	■	■	■	■	■	■	■	■	■	■	■	■	■	■	■	■
800 ²⁾	0.45	1,010	■	■	■	■	■	■	■	■	■	■	■	■	■	■	■	■	■	■	■	■

* Indicated loads are based on ISO 10567 and do not exceed 75% of tipping or 87% of hydraulic capacity, max. stick length without quick coupler, lifted 360° on firm with blocked oscillating axle

¹⁾ without ejector

²⁾ with ejector

³⁾ Shells for loose material

Max. material weight ■ = ≤ 1.8 t/m³, ■ = ≤ 1.5 t/m³, △ = ≤ 1.2 t/m³, - = not authorised

Clamshell Grab

with Two-Piece Boom 5.80 m (Standard Counterweight)

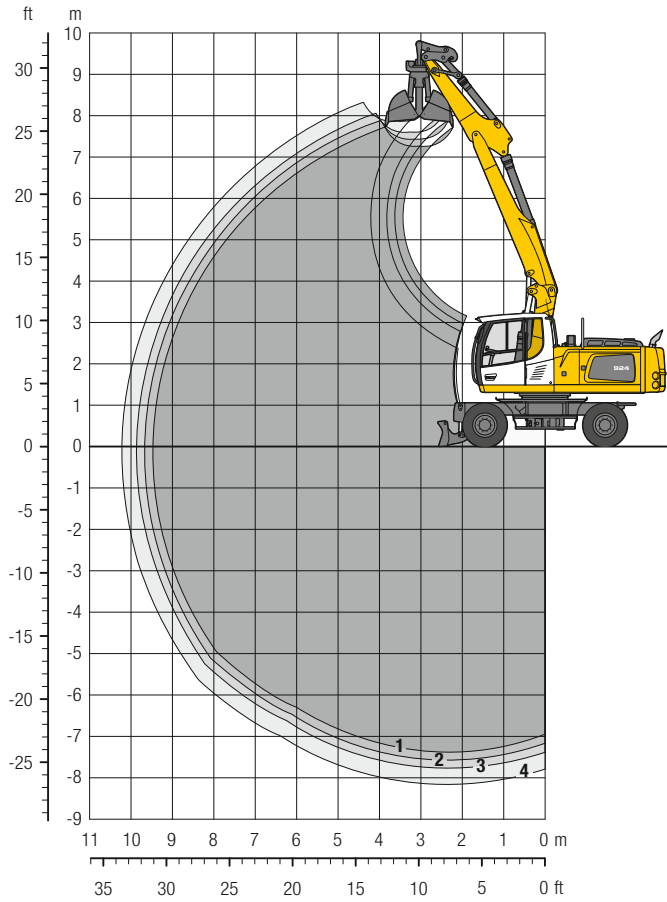

Digging Envelope

with quick coupler	1	2	3	4
Stick length	m 2.25	2.45	2.65	3.05
Max. digging depth	m 7.35	7.55	7.75	8.15
Max. reach at ground level	m 9.50	9.65	9.85	10.25
Max. dumping height	m 7.30	7.45	7.60	7.90

Clamshell Grab GM 10B

Max. tooth force	73 kN (7.4 t)
Max. torque of hydr. swivel	1.76 kNm

Operating Weight

The operating weight includes the basic machine with 8 tyres plus intermediate rings, two-piece boom 5.80 m, stick 2.45 m, quick coupler SWA 48 and clamshell grab GM 10B/1.00 m³ (1,000 mm without ejector).

Undercarriage versions	Weight (kg)
A 924 <i>Litronic</i> with rear blade	21,800
A 924 <i>Litronic</i> with rear outriggers + front blade	23,500
A 924 <i>Litronic</i> with rear + front outriggers	23,900
A 924 EW <i>Litronic</i> with rear blade	21,900
A 924 EW <i>Litronic</i> with rear outriggers + front blade	23,900
A 924 EW <i>Litronic</i> with rear + front outriggers	24,400

Clamshell Grab GM 10B Machine stability per ISO 10567* (75% of tipping capacity)

Width of clamshells mm	Capacity m ³	Weight kg	Stabilizers raised				Rear blade down				Rear outriggers + front blade down				Rear + front outriggers down			
			Stick length (m)				Stick length (m)				Stick length (m)				Stick length (m)			
			2.25	2.45	2.65	3.05	2.25	2.45	2.65	3.05	2.25	2.45	2.65	3.05	2.25	2.45	2.65	3.05
320 ¹⁾	0.17	770	■	■	■	■	■	■	■	■	■	■	■	■	■	■	■	
400 ¹⁾	0.22	820	■	■	■	■	■	■	■	■	■	■	■	■	■	■	■	
600 ¹⁾	0.35	860	■	■	■	■	■	■	■	■	■	■	■	■	■	■	■	
800 ¹⁾	0.45	910	■	■	■	△	■	■	■	■	■	■	■	■	■	■	■	
1,000 ¹⁾	0.60	970	■	△	■	—	■	■	△	■	■	■	■	■	■	■	■	
1,000 ¹⁾³⁾	1.00	1,040	—	—	—	—	—	—	—	■	■	■	■	■	■	■	■	
1,500 ¹⁾³⁾	1.50	1,160	—	—	—	—	—	—	—	■	■	△	△	■	■	■	■	
1,800 ¹⁾³⁾	1.80	1,280	—	—	—	—	—	—	—	△	△	—	—	■	■	■	■	
320 ²⁾	0.17	820	■	■	■	■	■	■	■	■	■	■	■	■	■	■	■	
400 ²⁾	0.22	880	■	■	■	■	■	■	■	■	■	■	■	■	■	■	■	
600 ²⁾	0.30	950	■	■	■	■	■	■	■	■	■	■	■	■	■	■	■	
800 ²⁾	0.45	1,010	■	■	■	△	■	■	■	■	■	■	■	■	■	■	■	

Clamshell Grab GM 10B Machine stability per ISO 10567* (75% of tipping capacity)

Width of clamshells mm	Capacity m ³	Weight kg	EW Stabilizers raised				EW Rear blade down				EW Rear outriggers + front blade down				EW Rear + front outriggers down			
			Stick length (m)				Stick length (m)				Stick length (m)				Stick length (m)			
			2.25	2.45	2.65	3.05	2.25	2.45	2.65	3.05	2.25	2.45	2.65	3.05	2.25	2.45	2.65	3.05
320 ¹⁾	0.17	770	■	■	■	■	■	■	■	■	■	■	■	■	■	■	■	
400 ¹⁾	0.22	820	■	■	■	■	■	■	■	■	■	■	■	■	■	■	■	
600 ¹⁾	0.35	860	■	■	■	■	■	■	■	■	■	■	■	■	■	■	■	
800 ¹⁾	0.45	910	■	■	■	■	■	■	■	■	■	■	■	■	■	■	■	
1,000 ¹⁾	0.60	970	■	■	■	△	■	■	■	■	■	■	■	■	■	■	■	
1,000 ¹⁾³⁾	1.00	1,040	—	—	—	—	△	△	—	■	■	■	■	■	■	■	■	
1,500 ¹⁾³⁾	1.50	1,160	—	—	—	—	—	—	—	■	■	■	■	■	■	■	■	
1,800 ¹⁾³⁾	1.80	1,280	—	—	—	—	—	—	—	■	△	△	△	■	■	■	■	
320 ²⁾	0.17	820	■	■	■	■	■	■	■	■	■	■	■	■	■	■	■	
400 ²⁾	0.22	880	■	■	■	■	■	■	■	■	■	■	■	■	■	■	■	
600 ²⁾	0.30	950	■	■	■	■	■	■	■	■	■	■	■	■	■	■	■	
800 ²⁾	0.45	1,010	■	■	■	■	■	■	■	■	■	■	■	■	■	■	■	

* Indicated loads are based on ISO 10567 and do not exceed 75% of tipping or 87% of hydraulic capacity, max. stick length without quick coupler, lifted 360° on firm with blocked oscillating axle

¹⁾ without ejector

²⁾ with ejector

³⁾ Shells for loose material

Max. material weight ■ = ≤ 1.8 t/m³, ■ = ≤ 1.5 t/m³, △ = ≤ 1.2 t/m³, — = not authorised

Clamshell Grab

with Mono Boom 5.65 m (Heavy Counterweight)

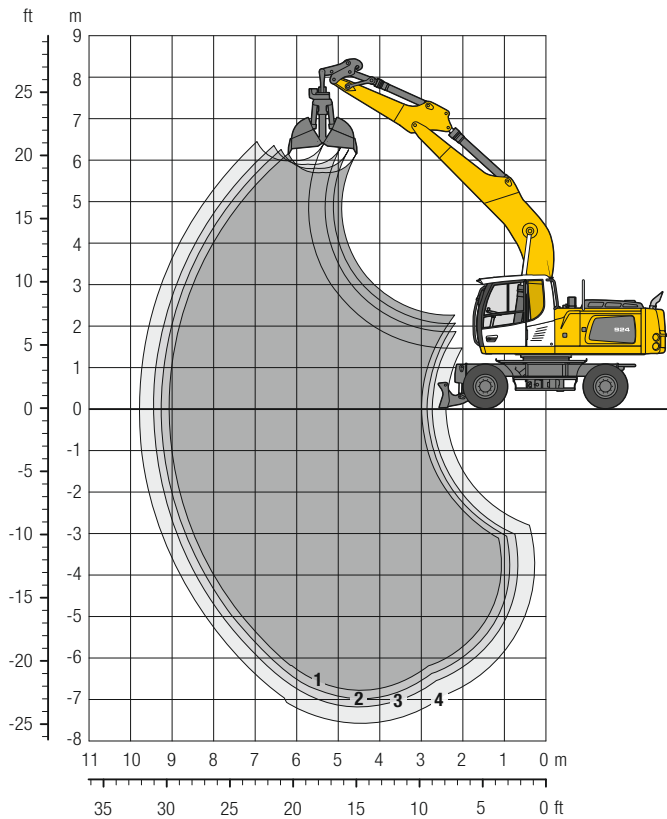

Digging Envelope

with quick coupler	1	2	3	4
Stick length	m 2.25	2.45	2.65	3.05
Max. digging depth	m 6.80	7.00	7.20	7.60
Max. reach at ground level	m 9.10	9.25	9.45	9.80
Max. dumping height	m 5.70	5.80	5.90	6.00

Clamshell Grab GM 10B

Max. tooth force	73 kN (7.4 t)
Max. torque of hydr. swivel	1.76 kNm

Operating Weight

The operating weight includes the basic machine with 8 tyres plus intermediate rings, mono boom 5.65 m, stick 2.45 m, quick coupler SWA 48 and clamshell grab GM 10B/1.00 m³ (1,000 mm without ejector).

Undercarriage versions	Weight (kg)
A 924 <i>Litronic</i> with rear blade	23,500
A 924 <i>Litronic</i> with rear blade + front outriggers	25,300
A 924 <i>Litronic</i> with rear outriggers + front blade	25,100
A 924 <i>Litronic</i> with rear + front outriggers	25,400
A 924 EW <i>Litronic</i> with rear blade	23,600
A 924 EW <i>Litronic</i> with rear blade + front outriggers	25,700
A 924 EW <i>Litronic</i> with rear outriggers + front blade	25,500
A 924 EW <i>Litronic</i> with rear + front outriggers	26,000

Clamshell Grab GM 10B Machine stability per ISO 10567* (75% of tipping capacity)

Width of clamshells mm	Capacity m³	Weight kg	Stabilizers raised				Rear blade down				Rear blade + front outriggers down				Rear outriggers + front blade down				Rear + front outriggers down			
			Stick length (m)				Stick length (m)				Stick length (m)				Stick length (m)				Stick length (m)			
			2.25	2.45	2.65	3.05	2.25	2.45	2.65	3.05	2.25	2.45	2.65	3.05	2.25	2.45	2.65	3.05	2.25	2.45	2.65	3.05
320 ¹⁾	0.17	770	■	■	■	■	■	■	■	■	■	■	■	■	■	■	■	■	■	■	■	■
400 ¹⁾	0.22	820	■	■	■	■	■	■	■	■	■	■	■	■	■	■	■	■	■	■	■	■
600 ¹⁾	0.35	860	■	■	■	■	■	■	■	■	■	■	■	■	■	■	■	■	■	■	■	■
800 ¹⁾	0.45	910	■	■	■	■	■	■	■	■	■	■	■	■	■	■	■	■	■	■	■	■
1,000 ¹⁾	0.60	970	■	■	■	■	■	■	■	■	■	■	■	■	■	■	■	■	■	■	■	■
1,000 ¹⁾³⁾	1.00	1,040	■	■	■	△	■	■	■	■	■	■	■	■	■	■	■	■	■	■	■	■
1,500 ¹⁾³⁾	1.50	1,160	-	-	-	-	△	△	-	-	■	■	■	■	■	■	■	■	■	■	■	■
1,800 ¹⁾³⁾	1.80	1,280	-	-	-	-	-	-	-	-	■	■	■	■	■	■	■	■	■	■	■	■
320 ²⁾	0.17	820	■	■	■	■	■	■	■	■	■	■	■	■	■	■	■	■	■	■	■	■
400 ²⁾	0.22	880	■	■	■	■	■	■	■	■	■	■	■	■	■	■	■	■	■	■	■	■
600 ²⁾	0.30	950	■	■	■	■	■	■	■	■	■	■	■	■	■	■	■	■	■	■	■	■
800 ²⁾	0.45	1,010	■	■	■	■	■	■	■	■	■	■	■	■	■	■	■	■	■	■	■	■

Clamshell Grab GM 10B Machine stability per ISO 10567* (75% of tipping capacity)

Width of clamshells mm	Capacity m³	Weight kg	EW Stabilizers raised				EW Rear blade down				EW Rear blade + front outriggers down				EW Rear outriggers + front blade down				EW Rear + front outriggers down			
			Stick length (m)				Stick length (m)				Stick length (m)				Stick length (m)				Stick length (m)			
			2.25	2.45	2.65	3.05	2.25	2.45	2.65	3.05	2.25	2.45	2.65	3.05	2.25	2.45	2.65	3.05	2.25	2.45	2.65	3.05
320 ¹⁾	0.17	770	■	■	■	■	■	■	■	■	■	■	■	■	■	■	■	■	■	■	■	■
400 ¹⁾	0.22	820	■	■	■	■	■	■	■	■	■	■	■	■	■	■	■	■	■	■	■	■
600 ¹⁾	0.35	860	■	■	■	■	■	■	■	■	■	■	■	■	■	■	■	■	■	■	■	■
800 ¹⁾	0.45	910	■	■	■	■	■	■	■	■	■	■	■	■	■	■	■	■	■	■	■	■
1,000 ¹⁾	0.60	970	■	■	■	■	■	■	■	■	■	■	■	■	■	■	■	■	■	■	■	■
1,000 ¹⁾³⁾	1.00	1,040	■	■	■	■	■	■	■	■	■	■	■	■	■	■	■	■	■	■	■	■
1,500 ¹⁾³⁾	1.50	1,160	△	△	-	-	■	△	△	△	■	■	■	■	■	■	■	■	■	■	■	■
1,800 ¹⁾³⁾	1.80	1,280	-	-	-	-	△	-	-	-	■	■	■	■	■	■	■	■	■	■	■	■
320 ²⁾	0.17	820	■	■	■	■	■	■	■	■	■	■	■	■	■	■	■	■	■	■	■	■
400 ²⁾	0.22	880	■	■	■	■	■	■	■	■	■	■	■	■	■	■	■	■	■	■	■	■
600 ²⁾	0.30	950	■	■	■	■	■	■	■	■	■	■	■	■	■	■	■	■	■	■	■	■
800 ²⁾	0.45	1,010	■	■	■	■	■	■	■	■	■	■	■	■	■	■	■	■	■	■	■	■

* Indicated loads are based on ISO 10567 and do not exceed 75% of tipping or 87% of hydraulic capacity, max. stick length without quick coupler, lifted 360° on firm with blocked oscillating axle

¹⁾ without ejector

²⁾ with ejector

³⁾ Shells for loose material

Max. material weight ■ = ≤ 1.8 t/m³, ■ = ≤ 1.5 t/m³, △ = ≤ 1.2 t/m³, - = not authorised

Equipments

Ditch Cleaning Buckets

Ditch Cleaning Buckets Machine stability per ISO 10567* (75% of tipping capacity)

Cutting width mm	Capacity ISO 7451 ¹⁾ m ³	Weight kg	Stabilizers raised			Rear blade down			Rear outriggers + front blade down			Rear + front outriggers down			EW Stabilizers raised			EW Rear blade down			EW Rear outriggers + front blade down			EW Rear + front outriggers down		
			Stick length (m)	Stick length (m)	Stick length (m)	Stick length (m)	Stick length (m)	Stick length (m)	Stick length (m)	Stick length (m)	Stick length (m)	Stick length (m)	Stick length (m)	Stick length (m)	Stick length (m)	Stick length (m)	Stick length (m)	Stick length (m)	Stick length (m)	Stick length (m)	Stick length (m)	Stick length (m)	Stick length (m)	Stick length (m)	Stick length (m)	
Two-piece boom 5.80 m (heavy counterweight)																										
1,500 ³⁾	0.50	430	■	■	■	■	■	■	■	■	■	■	■	■	■	■	■	■	■	■	■	■	■	■	■	
1,600 ²⁾	0.80	850	■	■	■	■	■	■	■	■	■	■	■	■	■	■	■	■	■	■	■	■	■	■	■	
2,000 ²⁾	0.50	690	■	■	■	■	■	■	■	■	■	■	■	■	■	■	■	■	■	■	■	■	■	■	■	
2,000 ³⁾	0.70	520	■	■	■	■	■	■	■	■	■	■	■	■	■	■	■	■	■	■	■	■	■	■	■	
2,000 ²⁾	0.70	880	■	■	■	■	■	■	■	■	■	■	■	■	■	■	■	■	■	■	■	■	■	■	■	
2,000 ³⁾	1.20	640	■	■	■	△	■	■	■	■	■	■	■	■	■	■	■	■	■	■	■	■	■	■	■	
2,000 ²⁾	1.00	940	■	■	■	△	■	■	■	■	■	■	■	■	■	■	■	■	■	■	■	■	■	■	■	
2,200 ²⁾	0.80	880	■	■	■	■	■	■	■	■	■	■	■	■	■	■	■	■	■	■	■	■	■	■	■	
2,200 ²⁾	1.15	980	△	△	△	—	■	■	△	△	—	■	■	■	■	■	■	■	■	■	■	■	■	■	■	
2,200 ²⁾	1.40	1,000	△	—	△	—	△	△	△	—	■	■	■	■	■	■	△	△	△	—	■	△	△	△	■	
2,400 ²⁾	0.85	890	■	■	■	■	■	■	■	■	■	■	■	■	■	■	■	■	■	■	■	■	■	■	■	
2,400 ³⁾	0.85	610	■	■	■	■	■	■	■	■	■	■	■	■	■	■	■	■	■	■	■	■	■	■	■	
2,400 ³⁾	1.25	1,000	△	△	△	—	■	△	△	△	■	■	■	■	■	■	■	△	△	△	■	■	■	■	■	
Two-piece boom 5.80 m (standard counterweight)																										
1,500 ³⁾	0.50	430	■	■	■	■	■	■	■	■	■	■	■	■	■	■	■	■	■	■	■	■	■	■	■	
1,600 ²⁾	0.80	850	△	—	△	—	■	△	△	—	■	■	■	■	■	■	■	△	△	—	■	■	■	■	■	
2,000 ²⁾	0.50	690	■	■	■	■	■	■	■	■	■	■	■	■	■	■	■	■	■	■	■	■	■	■	■	
2,000 ³⁾	0.70	520	■	■	■	△	■	■	■	■	■	■	■	■	■	■	■	■	■	■	■	■	■	■	■	
2,000 ²⁾	0.70	880	△	△	△	—	■	■	△	△	—	■	■	■	■	■	■	■	△	△	—	■	■	■	■	
2,000 ³⁾	1.20	640	—	—	—	—	—	—	—	—	—	■	■	■	■	■	■	—	—	—	△	△	—	—	■	
2,000 ²⁾	1.00	940	—	—	—	—	—	—	—	—	■	■	■	■	■	■	■	—	—	—	△	△	△	—	■	
2,200 ²⁾	0.80	880	△	—	△	—	△	△	△	—	■	■	■	■	■	■	■	■	△	△	—	■	■	■	■	
2,200 ²⁾	1.15	980	—	—	—	—	—	—	—	—	■	■	■	■	■	■	■	—	—	—	—	—	—	—	■	
2,200 ²⁾	1.40	1,000	—	—	—	—	—	—	—	—	■	■	■	■	■	■	△	—	—	—	—	—	—	—	■	
2,400 ²⁾	0.85	890	—	—	—	—	△	△	—	—	■	■	■	■	■	■	■	△	△	△	—	■	■	△	△	■
2,400 ³⁾	0.85	610	△	△	△	—	■	△	△	—	■	■	■	■	■	■	■	■	△	△	—	■	■	■	■	
2,400 ³⁾	1.25	1,000	—	—	—	—	—	—	—	—	■	■	■	■	■	■	■	—	—	—	—	—	—	—	■	
Mono boom 5.65 m (heavy counterweight)																										
1,500 ³⁾	0.50	430	■	■	■	■	■	■	■	■	■	■	■	■	■	■	■	■	■	■	■	■	■	■	■	
1,600 ²⁾	0.80	850	■	■	■	■	■	■	■	■	■	■	■	■	■	■	■	■	■	■	■	■	■	■	■	
2,000 ²⁾	0.50	690	■	■	■	■	■	■	■	■	■	■	■	■	■	■	■	■	■	■	■	■	■	■	■	
2,000 ³⁾	0.70	520	■	■	■	■	■	■	■	■	■	■	■	■	■	■	■	■	■	■	■	■	■	■	■	
2,000 ²⁾	0.70	880	■	■	■	■	■	■	■	■	■	■	■	■	■	■	■	■	■	■	■	■	■	■	■	
2,000 ³⁾	1.20	640	■	■	■	△	■	■	■	■	■	■	■	■	■	■	■	■	■	■	■	■	■	■	■	
2,000 ²⁾	1.00	940	■	■	■	■	■	■	■	■	■	■	■	■	■	■	■	■	■	■	■	■	■	■	■	
2,200 ²⁾	0.80	880	■	■	■	■	■	■	■	■	■	■	■	■	■	■	■	■	■	■	■	■	■	■	■	
2,200 ²⁾	1.15	980	■	■	△	△	■	■	■	△	■	■	■	■	■	■	■	■	■	■	■	■	■	■	■	
2,200 ²⁾	1.40	1,000	△	△	—	—	△	△	△	△	■	■	■	■	■	■	■	■	△	△	△	■	■	■	■	
2,400 ²⁾	0.85	890	■	■	■	■	■	■	■	■	■	■	■	■	■	■	■	■	■	■	■	■	■	■	■	
2,400 ³⁾	0.85	610	■	■	■	■	■	■	■	■	■	■	■	■	■	■	■	■	■	■	■	■	■	■	■	
2,400 ³⁾	1.25	1,000	△	△	△	—	■	△	△	—	■	■	■	■	■	■	■	■	△	△	—	■	■	■	■	

* Indicated loads are based on ISO 10567 and do not exceed 75% of tipping or 87% of hydraulic capacity, max. stick length without quick coupler, lifted 360° on firm with blocked oscillating axle

¹⁾ comparable with SAE (heaped)

²⁾ with 2 x 50° rotator

³⁾ rigid ditch cleaning bucket

Max. material weight ■ = ≤ 1.8 t/m³, ■ = ≤ 1.5 t/m³, △ = ≤ 1.2 t/m³, — = not authorised

Equipments

Tilt Buckets

Tilt Buckets Machine stability per ISO 10567* (75% of tipping capacity)

Cutting width mm	Capacity ISO 7451 ¹⁾ m ³	Weight kg	Stabilizers raised				Rear blade down				Rear outriggers + front blade down				Rear + front outriggers down				EW Stabilizers raised				EW Rear blade down				EW Rear outriggers + front blade down				EW Rear + front outriggers down				
			Stick length (m)				Stick length (m)				Stick length (m)				Stick length (m)				Stick length (m)				Stick length (m)				Stick length (m)								
			2.25	2.45	2.65	3.05	2.25	2.45	2.65	3.05	2.25	2.45	2.65	3.05	2.25	2.45	2.65	3.05	2.25	2.45	2.65	3.05	2.25	2.45	2.65	3.05	2.25	2.45	2.65	3.05	2.25	2.45	2.65	3.05	
Two-piece boom 5.80 m (heavy counterweight)																																			
1,500 ²⁾	1.20	970	△	△	△	-	■	■	■	△	△	■	■	■	■	■	■	■	■	■	△	△	■	■	■	■	■	■	■	■	■	■	■	■	
1,600 ²⁾	0.80	820	■	■	■	■	■	■	■	■	■	■	■	■	■	■	■	■	■	■	■	■	■	■	■	■	■	■	■	■	■	■	■		
1,600 ²⁾	1.00	890	■	■	■	△	■	■	■	■	■	■	■	■	■	■	■	■	■	■	■	■	■	■	■	■	■	■	■	■	■	■	■		
1,600 ²⁾	1.35	970	△	-	△	-	△	△	△	-	■	■	■	■	■	■	■	■	■	■	△	△	△	-	■	■	△	△	■	■	■	■	■	■	■
1,600 ²⁾	1.55	1,120	-	-	-	-	-	-	-	-	■	■	■	■	■	■	■	■	■	■	△	-	-	-	△	△	△	-	■	■	■	■	■	■	■
Two-piece boom 5.80 m (standard counterweight)																																			
1,500 ²⁾	1.20	970	-	-	-	-	-	-	-	-	■	■	■	■	■	■	■	■	■	-	-	-	-	-	-	-	-	■	■	■	■	■	■	■	
1,600 ²⁾	0.80	820	△	-	△	-	■	△	△	-	■	■	■	■	■	■	■	■	■	■	■	△	△	-	■	■	■	△	■	■	■	■	■	■	■
1,600 ²⁾	1.00	890	-	-	-	-	-	-	-	-	■	■	■	■	■	■	■	■	■	■	△	-	-	-	△	△	△	-	■	■	■	■	■	■	■
1,600 ²⁾	1.35	970	-	-	-	-	-	-	-	-	-	-	-	-	-	-	-	-	-	-	-	-	-	-	-	-	-	■	■	■	■	■	■	■	
1,600 ²⁾	1.55	1,120	-	-	-	-	-	-	-	-	■	■	△	△	■	■	■	■	■	■	-	-	-	-	-	-	-	-	■	■	■	■	■	■	■
Mono boom 5.65 m (heavy counterweight)																																			
1,500 ²⁾	1.20	970	■	△	△	△	■	■	■	△	■	■	■	■	■	■	■	■	■	■	■	△	■	■	■	■	■	■	■	■	■	■	■	■	
1,600 ²⁾	0.80	820	■	■	■	■	■	■	■	■	■	■	■	■	■	■	■	■	■	■	■	■	■	■	■	■	■	■	■	■	■	■	■	■	
1,600 ²⁾	1.00	890	■	■	■	■	■	■	■	■	■	■	■	■	■	■	■	■	■	■	■	■	■	■	■	■	■	■	■	■	■	■	■	■	
1,600 ²⁾	1.35	970	△	△	△	-	■	△	△	△	■	■	■	■	■	■	■	■	■	■	■	△	△	■	■	■	■	■	■	■	■	■	■	■	■
1,600 ²⁾	1.55	1,120	-	-	-	-	△	△	-	-	■	■	■	■	■	■	■	■	■	■	△	△	-	-	△	△	△	■	■	■	■	■	■	■	■

* Indicated loads are based on ISO 10567 and do not exceed 75% of tipping or 87% of hydraulic capacity, max. stick length without quick coupler, lifted 360° on firm with blocked oscillating axle

¹⁾ comparable with SAE (heaped)

²⁾ with 2 x 50° rotator

Max. material weight ■ = ≤ 1.8 t/m³, ■ = ≤ 1.5 t/m³, △ = ≤ 1.2 t/m³, - = not authorised

Equipment

Undercarriage

Dual-circuit braking system	•
Rear stabilizer blade	+
Rear stabilizer blade + front outriggers	+
Digging brake, automatic	•
Tyres (twin tyres) Mitas EM 22	•
Individual control outriggers	+
Travel speed levels (four)	•
Load holding valve on each stabilization cylinder	•
Powershift transmission, semiautomatic	•
Parking brake, maintenance-free	•
Rear outriggers + front stabilizer blade	+
Rear + front outriggers	+
Tyres, variants	+
Protection for piston rods, stabilizer cylinder	+
Speeder**	+
Storage compartment left – lockable	•
Storage compartment right – lockable	+
Undercarriage EW 2.75 m/9'	+
Tool equipment, extended	+

Uppercarriage

Uppercarriage rear light, 2 pieces, LED	+
Uppercarriage right side light, 1 piece, LED	+
Refuelling system with filling pump	+
Main battery switch for electrical system	•
Engine hood with gas spring	•
Amber beacon, at uppercarriage, LED double flash	+
Service doors, lockable	•

Hydraulic System

Shut-off valve between hydraulic tank and pump(s)	•
Pressure test fittings	•
Accumulator for controlled lowering of the equipment with the engine shut down	•
Hydraulic oil filter with integrated microfilter	•
Liebherr hydraulic oil from -20 °C to +40 °C	•
Liebherr hydraulic oil, biologically degradable	+
Liebherr hydraulic oil, specially for warm or cold regions	+
Bypass filter	+
PowerLift	+
Switchover high pressure circuit and tipping cylinder	+
Switchover high pressure circuit and two-piece boom	+

Diesel Engine

Fuel anti-theft device	+
Liebherr particle filter	•
Reversible fan drive, fully automatic	+
Air pre-filter with dust discharge	+
Automatic engine shut-down (time adjustable)	+
Preheating fuel	+

Operator's Cab

Storage compartment	•
Stabilizer, proportional control on left joystick	•
Cab lights rear, LED	+
Cab lights front, halogen (under rain cover)	•
Cab lights front, LED (above rain cover)	+
Cab lights front, LED (under rain cover)	+
Exterior mirror, electrical adjustable, with heating	+
Mechanical hour meters, readable from outside the cab	•
Roof window made from impact-resistant laminated safety glass	+
Slewing gear brake Comfort, button on the left or right joystick	+
Slewing gear brake, rocker switch in the right joystick	•
Driver's code to start the machine, individual*	+
Operator's seat Standard	•
Operator's seat Comfort	+
Operator's seat Premium	+
Driving alarm (acoustic signal is emitted during travel, can be switched ON/OFF)	+
Fire extinguisher	+
Front screen made from impact-resistant laminated safety glass – not adjustable	+
Windscreen retractable (including upper part)	•
Intermittent windscreen wiper with wiper washer	•
Cruise control	•
Rubber floor mat, removable	•
Dome light	•
Joystick steering	+
Coat hook	•
Automatic air conditioning	•
Fuel consumption indicator	•
Electric cooler	+
Steering wheel, wide version (cost-neutral option)	+
Steering column adjustable horizontally	•
LiDAT, vehicle fleet management	•
Emergency exit rear window	•
Positioning swing brake	+
Proportional control	•
Radio Comfort, control via display with handsfree set	+
Preparation for radio installation	•
Rain cover over front window opening	•
ROPS cab protection	•
Back-up alarm (acoustic signal is emitted traveling backward, can not be switched off)	+
Amber beacon, on cabin, LED double flash	+
All tinted windows	•
Windscreen wiper, roof	+
Windshield wiper, entire windscreen	•
Door with sliding window	•
Top guard	+
Front guard, adjustable	+
Right side window and windshield made from laminated safety glass	•
Sun visor	+
Sun blind	•
Auxiliary heating, adjustable (week time switch)	+
Left control console, folding	•
Electronic immobilizer	+
Cigarette lighter	•



Equipment

Boom lights, 2 pieces, halogen	•
Boom lights, 2 pieces, LED	+
Stick lights, 2 pieces, LED	+
High pressure circuit incl. unpressurised return line and Tool Control	+
Electronic lift limitation	+
Security for hoist cylinder for hydraulic attachments	+
Load holding valve bucket cylinder	+
Load lug on stick	+
Leak oil line, additional for attachments	+
Liebherr ditch cleaning bucket	+
Liebherr quick coupler, hydraulic or mechanical	+
Liebherr tilt bucket	+
Liebherr tilt rotator	+
Liebherr sorting grab	+
Liebherr backhoe bucket	+
Liebherr tooth system	+
Liebherr clamshell grab	+
Medium pressure circuit incl. lines	+
Mono boom	+
Mono boom, HD version	+
Pipe fracture safety valves hoist cylinders	•
Pipe fracture safety valve stick cylinder	•
Return line, pressureless (in high pressure circuit option included)	+
Hose quick coupling at end of stick	•
Quick coupling system LIKUFIX	+
Protection for bottom side of stick	+
Tool Control, 20 attachment adjustments selectable over the display	+
Overload warning device	•
Two-piece boom	+
Two-piece boom, HD version	+



Complete Machine

Lubrication	
Lubrication undercarriage, manually – decentralised (grease points)	•
Lubrication undercarriage, manually – centralised (one grease point)	+
Central lubrication system for uppercarriage and equipment, automatically (without quick coupler and connecting link) *	•
Central lubrication system, extension for quick coupler	+
Central lubrication system, extension for connecting link	+
Special coating	
Custom painting for attachments	+
Special coating, variants	+
Monitoring	
Rear view monitoring with camera	•
Side view monitoring with camera	•
Skyview 360° (side camera not available)	+
Machine guidance system	
Preparation	+

• = Standard, + = Option

* = country-dependent, ** = depending upon the country partially only 25 km/h permitted

Options and / or special equipments, supplied by vendors other than Liebherr, are only to be installed with the knowledge and approval of Liebherr in order to retain warranty.

The Liebherr Group of Companies



Wide Product Range

The Liebherr Group is one of the largest construction equipment manufacturers in the world. Liebherr's high-value products and services enjoy a high reputation in many other fields. The wide range includes domestic appliances, aerospace and transportation systems, machine tools and maritime cranes.

Exceptional Customer Benefit

Every product line provides a complete range of models in many different versions. With both their technical excellence and acknowledged quality, Liebherr products offer a maximum of customer benefits in practical applications.

State-of-the-art Technology

To provide consistent, top quality products, Liebherr attaches great importance to each product area, its components and core technologies. Important modules and components are developed and manufactured in-house, for instance the entire drive and control technology for construction equipment.

Worldwide and Independent

Hans Liebherr founded the Liebherr family company in 1949. Since then, the family business has steadily grown to a group of more than 130 companies with more than 46,000 employees located on all continents. The corporate headquarters of the Group is Liebherr-International AG in Bulle, Switzerland. The Liebherr family is the sole owner of the company.

www.liebherr.com