

Technical data
Hydraulic lift crane

LR 1250
Litronic®

Complies with ANSI/ASME B 30.5

1004.02



LIEBHERR

Dimensions

Basic machine with undercarriage

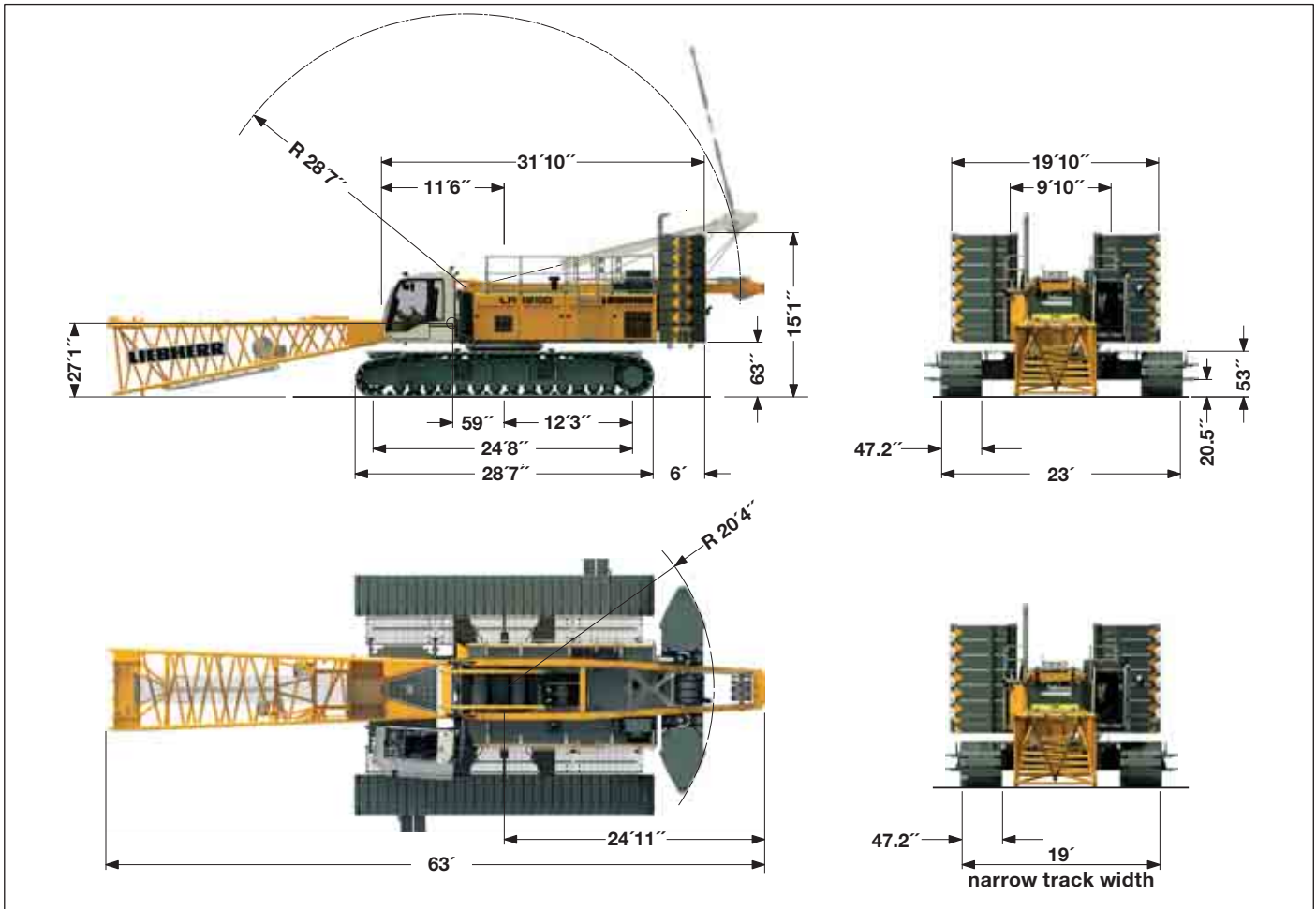

Operating weight

The operating weight includes the basic machine with crawlers, 2 main winches 26,980 lbf including wire ropes (853 ft and 1624 ft) and 66 ft main boom, consisting of A-frame, boom foot (33 ft), boom head (23 ft) and boom extension (10 ft), 181,440 lbs basic counterweight, 79,400 lbs carbody counterweight and 551,200 lbs hook block.

Total weight _____ approx. 462,970 lbs

Ground pressure

Ground bearing pressure _____ 16.5 PSI

Equipment

Main boom (No. 2320.xx) max. length	_____	282 ft
High reach (No. 2320.xx and 1916.xx)	_____	384 ft
Luffing jib (No. 1916.xx) max. length	_____	312 ft
Max. combination	_____ main boom	174 ft
	_____ luffing jib	312 ft
Fixed jib (No. 1008.xx)	_____	36 ft - 85 ft
Auxiliary jib	53,000 lbs (option 79,400 lbs)	

Remarks

1. The lifting capacities stated are valid for lifting operation only (corresponding with crane classification according to F.E.M. 1.001. crane group A1).
2. Crane standing on firm, horizontal ground.
3. The weight of the lifting device (hoisting ropes, hook block, shackle etc.) must be deducted from the gross lifting capacity to obtain a net lifting value.
4. Additional equipment on boom (e.g. boom walkways, auxiliary jib) must be deducted to get the net lifting capacity.
5. For max. wind speed please refer to lift chart in operator's cab or manual.
6. Working radii are measured from center of swing and under load.
7. The lifting capacities are valid for 360 degrees of swing.
8. Calculation of stability under load is based on ANSI/ASME B 30.5 load ratings as well as ISO 4305 Table 2 and is tested according to SAE J765.
9. Loads for calculation of structures are corresponding to F.E.M. 1.001-1998 and are tested according to SAE J987.

Transport dimensions and weights

Basic machine and main boom (No. 2320.xx)

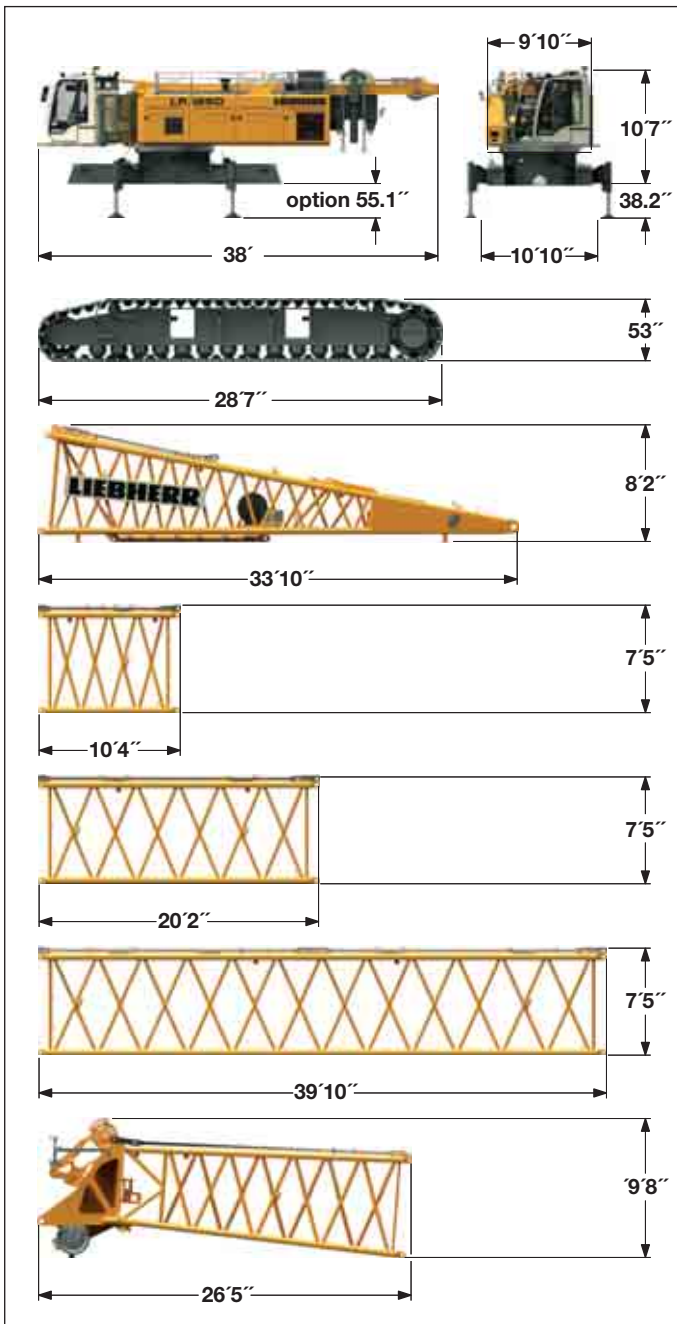

1) Pendant straps for main boom • 2) Pendant straps for jib

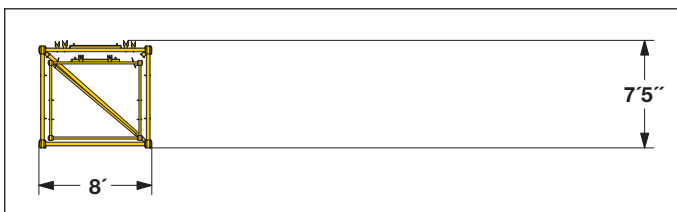

*) Including pendant straps

Basic machine

with A-frame, 2x 26,980 lbf crane winches without boom foot, hoist ropes, basic counterweight and crawlers

Width	9'10"
Weight	93,700 lbs
Weight of hoist rope	2.28 lbs/ft

Crawler

2 x

Track pads	47.2 inch
Width	47.2 inch
Weight	43,650 lbs

Boom foot (No. 2320.25)

Width	8'
Weight incl. winch and rope	12,350 lbs
Weight without winch	8,820 lbs

Boom section (No. 2320.23)

10 ft

Width	8'
Weight with HPT ¹⁾	1,830 lbs
Weight with HPT ¹⁾ and NDL ²⁾	2,030 lbs

Boom section (No. 2320.23)

20 ft

Width	8'
Weight with HPT ¹⁾	2,855 lbs
Weight with HPT ¹⁾ and NDL ²⁾	3,210 lbs

Boom section (No. 2320.23)

40 ft

Width	8'
Weight with HPT ¹⁾	5,160 lbs
Weight with HPT ¹⁾ and NDL ²⁾	5,930 lbs

Boom head (No. 2320.23)

Width	8'
Weight with HPT ¹⁾	9,480 lbs

Boom transport option

(No. 2320.xx/1916.xx)	40/40	20/20	10/10	ft
Length	40'2"	20'6"	10'8"	
Weight*	8,690	4,730	3,250	lbs

Transport dimensions and weights

Luffing jib (No. 1916.xx)

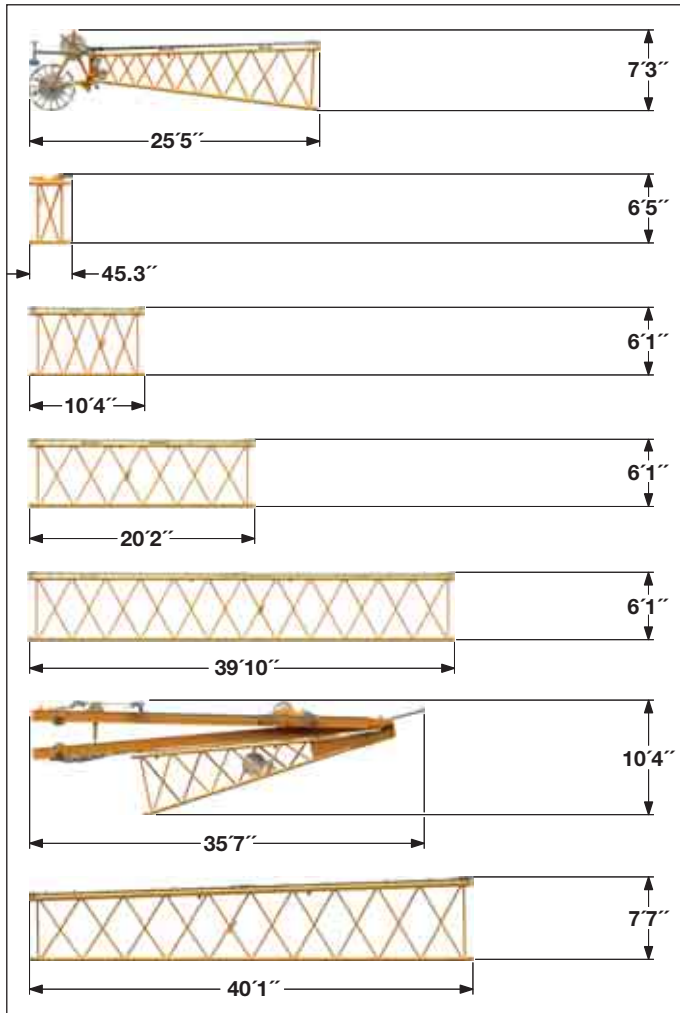

Luffing jib head (No. 1916.21)

Width	6'7"
Weight*	3,420 lbs

L-boom jib section (No. 1916.22) **39.4 inch**

Width	6'7"
Weight*	1,015 lbs

Luffing jib section (No. 1916.18) **10 ft**

Width	6'7"
Weight*	1,050 lbs

Luffing jib section (No. 1916.18) **20 ft**

Width	6'7"
Weight*	1,525 lbs

Luffing jib section (No. 1916.18) **40 ft**

Width	6'7"
Weight*	2,755 lbs

Luffing jib foot with A-frames (No. 1916.22)

Width	6'7"
Weight*	13,890 lbs

L-boom section tapered (No. 2320/1916.20) **40 ft**

Width	8'
Weight*	3,750 lbs

Fixed jib (No. 1008.xx)

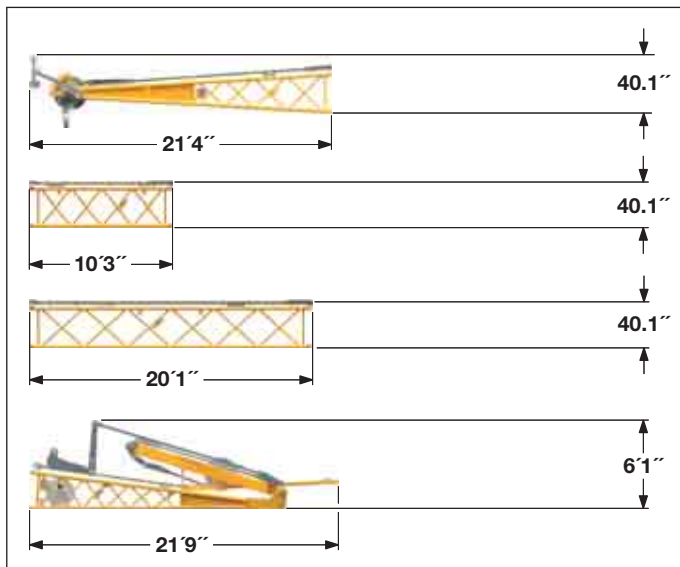

Fixed jib head (No. 1008.20)

Width	43 inch
Weight*	2,030 lbs

Fixed jib section (No. 1008.17) **10 ft**

Width	43 inch
Weight*	660 lbs

Fixed jib section (No. 1008.17) **20 ft**

Width	43 inch
Weight*	1,005 lbs

Fixed jib foot with A-frame (No. 1008.20)

Width	7'3"
Weight*	4,300 lbs

*) Including pendant straps

Transport dimensions and weights

Counterweight

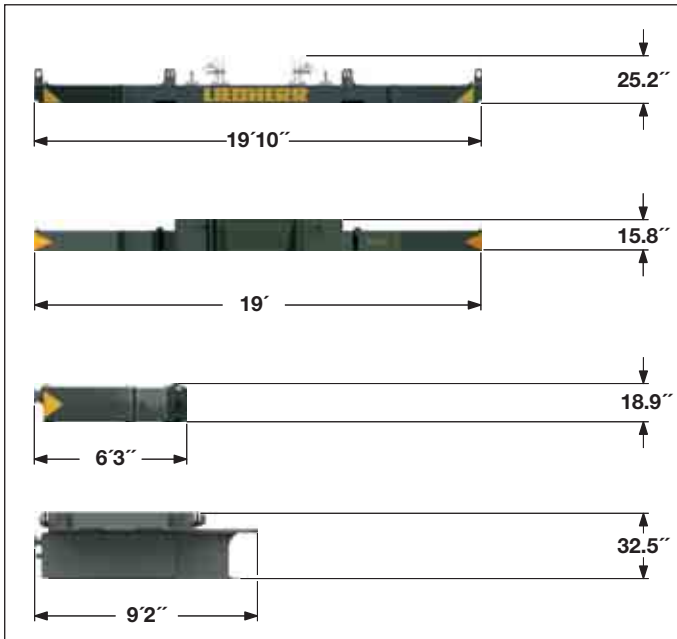

Counterweight **1 x**

Width	5'5"
Weight	26,455 lbs

Counterweight **1 x**

Width	5'5" mm
Weight	22,046 lbs

Counterweight **12 x**

Width	4'6"
Weight	11,023 lbs

Carbody counterweight **2 x**

Width	11'
Weight	21,605 lbs

Carbody counterweight **2 x**

Width	11'
Weight	18,300 lbs

Mid fall (option)

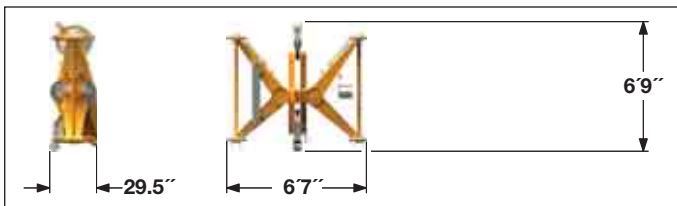

Mid fall section (No. 1916.xx) **19.7 inch**

Width	29.5 inch
Weight	1,580 lbs

Hooks

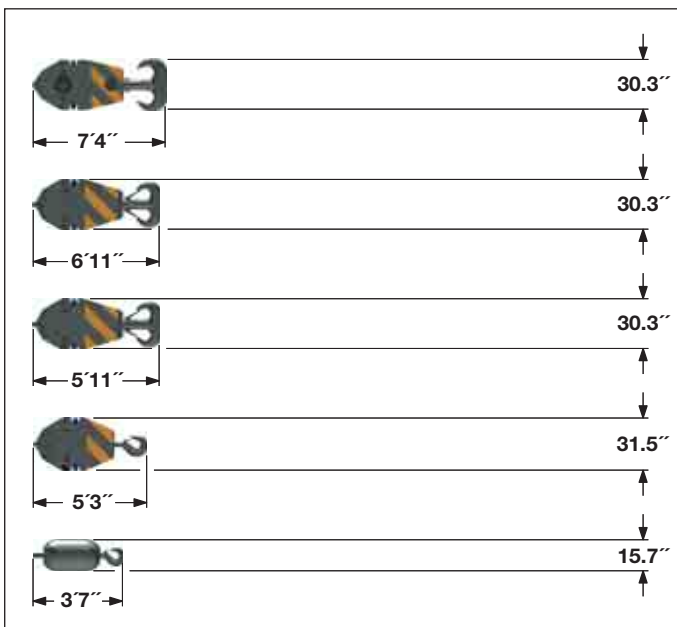

551,200 lbs hook block - 11 sheaves

Width	40.6 inch	49.2 inch
Weight	5,070 lbs	7,055 lbs

352,800 lbs hook block - 7 sheaves

Width	25.2 inch	29.9 inch	34.6 inch
Weight	3,307 lbs	4,960 lbs	6,614 lbs

220,500 lbs hook block - 5 sheaves

Width	21.3 inch	25.2 inch	27.6 inch
Weight	2,866 lbs	3,970 lbs	5,070 lbs

88,200 lbs hook block - 1 sheave

Width	11.8 inch	15.7 inch	19.7 inch
Weight	1,545 lbs	2,425 lbs	3,310 kg

27,600 lbs single hook

Width	15.7 inch
Weight	1,325 lbs

Technical description



Engine

Power rating according to ISO 9249, 270 kW (362 hp) at 2000 rpm
Engine type _____ Liebherr D 936 A7 SCR
Fuel tank _____ 211 gal capacity with continuous level indicator and reserve warning
Engine complies with NRMM exhaust certification EPA/CARB Tier 4i or 97/68 EC Stage IIIB.



Hydraulic system

A double axial displacement pump supplies the open loop hydraulic system, allowing all functions to be operated simultaneously. To minimize peak pressure an automatic working pressure cut-off is integrated in the pump.
All filters are electronically monitored.
The use of synthetic environmentally friendly (biodegradable) oils is possible.
Working pressure _____ max. 350 bar
Oil tank capacity _____ 650 l



Luffing jib winch

Line pull _____ max. 23,605 lbf
Rope diameter _____ 20 mm
Jib luffing _____ 51 sec. from 15° to 78°



Boom winch

Line pull _____ max. 48,784 lbf
Rope diameter _____ 24 mm
Boom up _____ 130 sec. from 15° to 86°



Swing

Consists of rollerbearing with external teeth, swing drive with fixed axial piston hydraulic motor, spring loaded and hydraulically released multi-disc holding brake, planetary gearbox and pinion.
Both swing modes are possible – speed control or free swing.
A multi-disc holding brake acts automatically at zero swing motion.
Swing speed from 0 – 3 rpm continuously variable.



Main winches

Line pull (1st layer) _____ max. 39,345 lbf
Line pull (7th layer) _____ 26,980 lbf
Rope diameter _____ 26 mm
Drum diameter _____ 22.8 inch
Rope speed _____ 0 – 446 ft/min
Rope capacity in 7 layers _____ 1604 ft

The winches are outstanding in their compact design and easy assembly.

Propulsion is via a planetary gearbox in an oil bath.

Load support by the hydraulic system; additional safety factor provided by a spring loaded, multi-disc holding brake.

The main winches use pressure controlled, variable flow hydraulic motors. This system features sensors that automatically adjust oil flow to provide max. winch speed depending on load.

Option – winch with free-fall system:

Clutch and braking functions on the free-fall system are provided by a compact designed, low wear and maintenance-free multi-disc brake.



Crawlers

Propulsion through axial piston motor, hydraulically released spring loaded multi-disc brake, crawler tracks, hydraulic chain tensioning device.

Track pads _____ 47.2 inch

Drive speed _____ 0 – 1 mph



Control

The heart of the hydraulic crawler cranes is the Liebherr control system which has been developed and manufactured in-house.

It includes all control and monitoring functions and is designed to withstand extreme environmental conditions and heavy duty construction tasks. Complete machine operating data as well as warning signals and irregularities are clearly displayed on the high resolution monitor in the operator's cab in the required language.

The electro-hydraulic proportional control allows several movements to be performed simultaneously. This ensures that all categories of loads can be positioned with utmost precision.

Option:

- GSM/GPRS telematics module



Noise emission

Noise emissions correspond with 2000/14/EC directive on noise emission by equipment used outdoors.

Boom combinations



Main boom No. 2320.xx — 282 ft

Max. combination — 384 ft

Max. combination — 318 ft

Max. combination — 486 ft

Main boom No. 2320.xx — 141 ft

Tapered

No. 2320/1916.xx — 40 ft

Luffing jib

No. 1916.xx — 203 ft

Main boom No. 2320.xx — 233 ft

Fixed jib

No. 1008.xx — 85 ft

Main boom No. 2320.xx — 174 ft

Luffing jib

No. 1916.xx — 312 ft

Main boom No. 2320.xx — 184 ft

Luffing jib

No. 1916.xx — 243 ft

Self assembly system

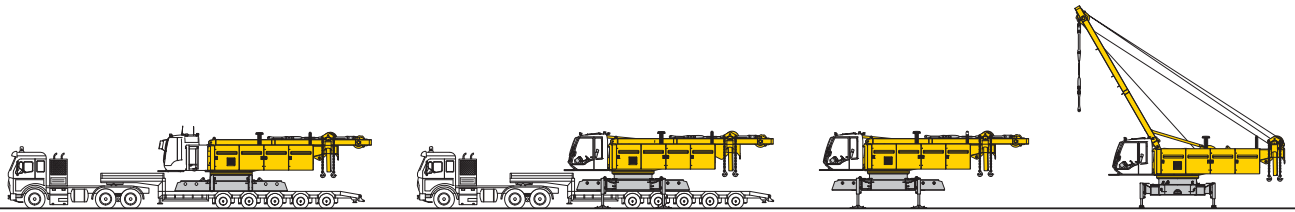

Unloading of basic machine

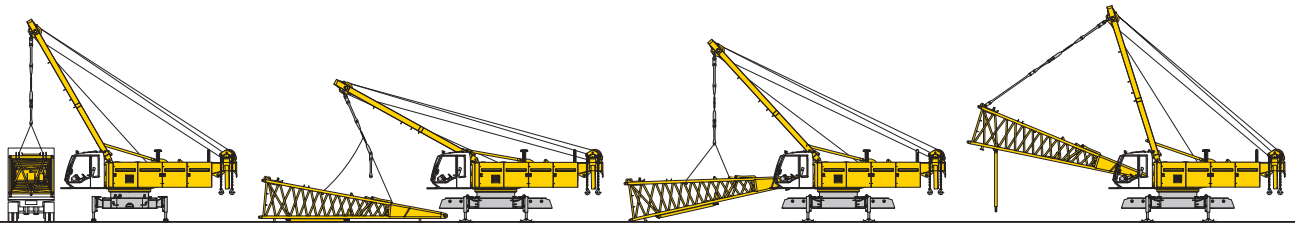

Unloading and assembly of boom foot

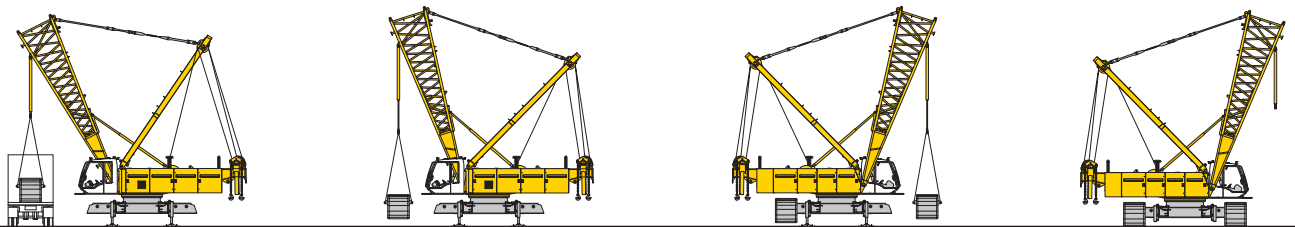

Unloading and assembly of crawlers

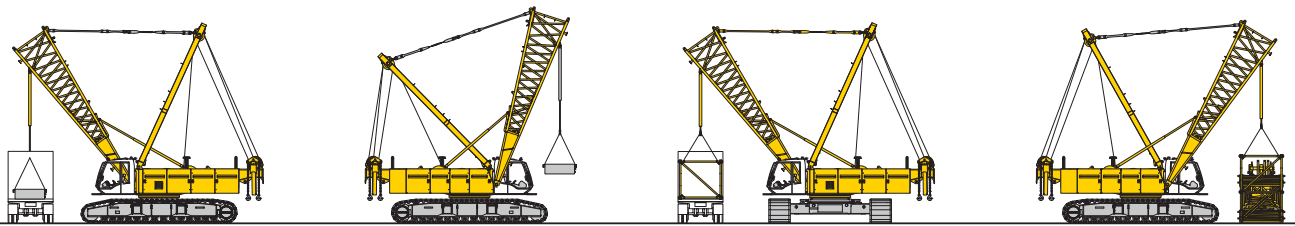

Unloading and assembly of carbody counterweight

Unloading and assembly of boom

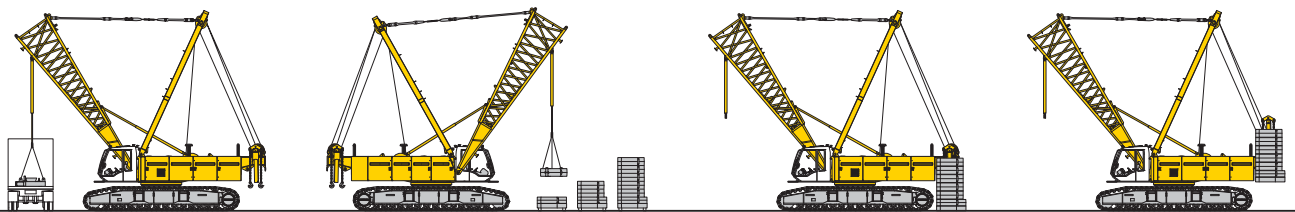

Unloading and assembly of counterweight

Erecting of main boom to working position

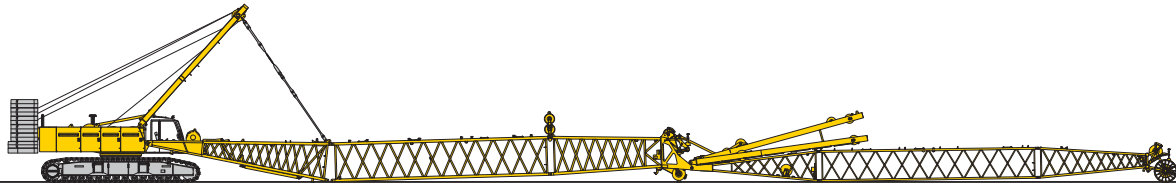

Assembly of boom

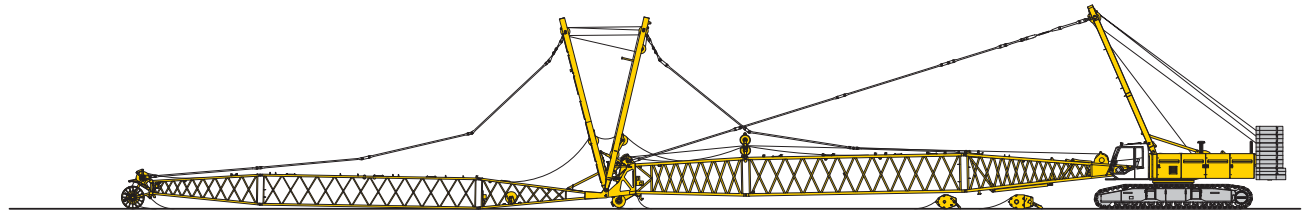

Reeving of hoist and luffing jib ropes

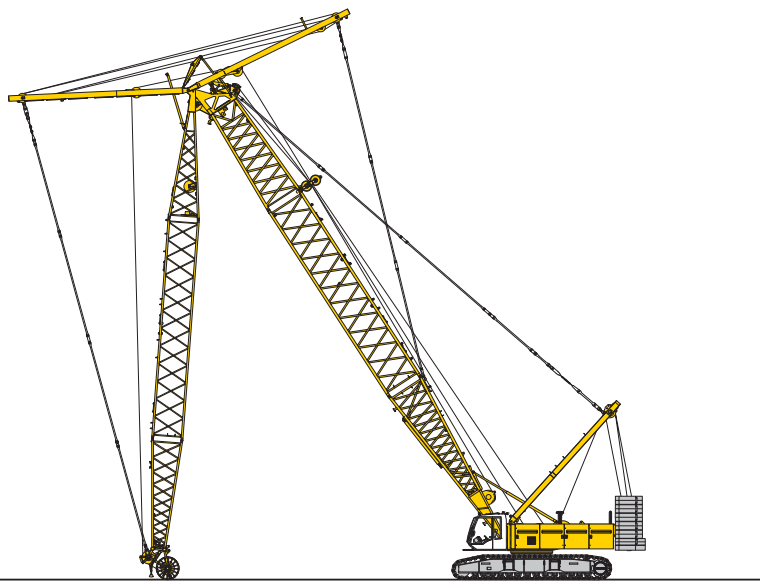

Erecting of main boom and luffing jib

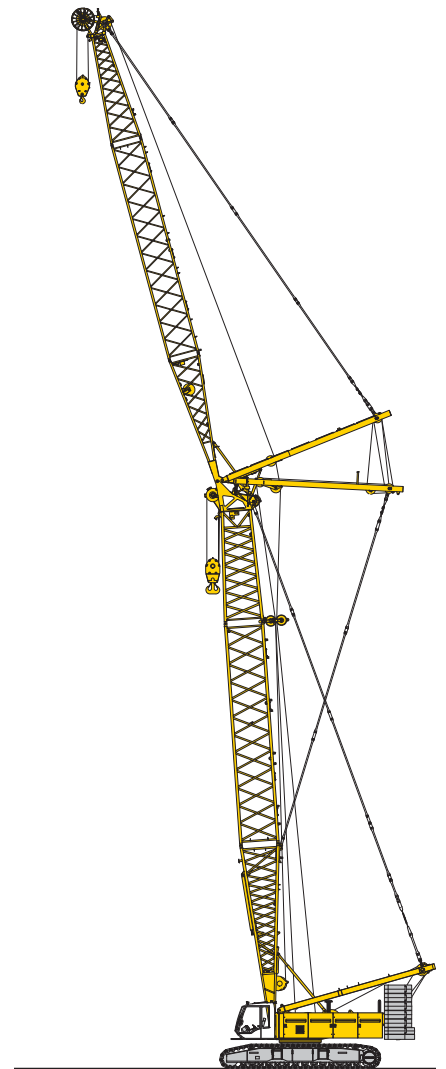

Working position

Working range - main boom (No. 2320.xx) 86° - 15°

181,440 lbs counterweight and 79,400 lbs carbody counterweight

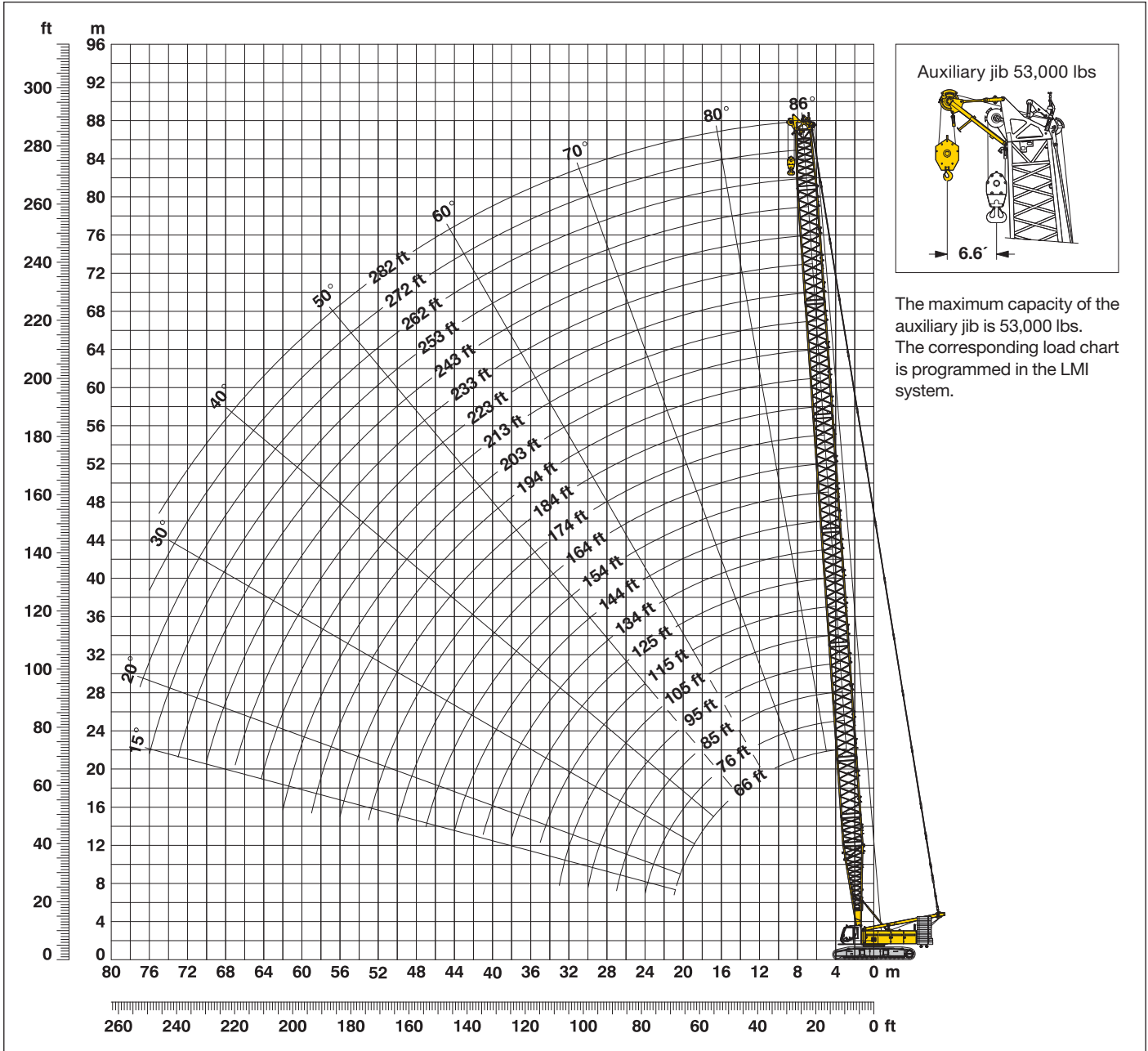

Main boom configuration (Table 1 – No. 2320.xx)

Configuration for boom lengths (66 ft - 282 ft)																												
Boom foot	Length*	Amount of boom extensions																										
		33 ft	43 ft	53 ft	63 ft	73 ft	83 ft	93 ft	103 ft	113 ft	123 ft	133 ft	143 ft	153 ft	163 ft	173 ft	183 ft	193 ft	203 ft	213 ft	223 ft	233 ft	243 ft	253 ft	263 ft	273 ft	282 ft	
33 ft	33 ft	1	1	1	1	1	1	1	1	1	1	1	1	1	1	1	1	1	1	1	1	1	1	1	1	1	1	1
Boom insert	10 ft	1		1		1		1		1		1		1		1		1		1		1		1		1		1
Boom insert	20 ft		1	1		1		1		1		1		1		1		1		1		1		1		1		1
Boom insert	40 ft				1	1	1	1	2	2	2	2	3	3	3	3	4	4	4	4	5	5	5	5	5	5	5	5
Boom head	23 ft	1	1	1	1	1	1	1	1	1	1	1	1	1	1	1	1	1	1	1	1	1	1	1	1	1	1	1
Boom length (ft)		66	76	85	95	105	115	125	134	144	154	164	174	184	194	203	213	223	233	243	253	262	272	282				

*Actual lengths of boom sections are metric (e.g. 3m, 6m, 7m, 10m, 12m). The figures shown above are approximate conversions to feet.

Lift chart for main boom (No. 2320.xx)

181,440 lbs counterweight and 79,400 lbs carbody counterweight

Capacities in 1000 lbs for boom lengths (66 ft - 282 ft) – with 26,980 lbf winches

Radius (ft)	Boom length in (ft)												Radius (ft)
	66 lbs	85 lbs	105 lbs	125 lbs	144 lbs	164 lbs	184 lbs	203 lbs	223 lbs	243 lbs	262 lbs	282 lbs	
18,9					279,9								18,9
20				318,4	279,9	240,3							20
25		336,7	320,8	297,5	270,7	234,9	202,8	174,4	148,3				25
30	270,6	270,7	270,8	266,9	248,0	224,2	195,7	170,1	147,0	127,7	111,4	94,4	30
35	214,4	214,5	214,4	214,1	213,9	209,0	187,1	166,1	145,1	125,4	109,8	93,9	35
40	176,9	176,9	176,8	176,5	176,1	175,6	175,2	161,6	142,2	123,5	108,3	93,0	40
45	150,1	150,1	150,0	149,5	149,1	148,6	148,1	147,5	139,4	121,2	106,5	92,0	45
50	130,0	130,0	129,8	129,3	128,9	128,3	127,8	127,1	126,6	119,4	104,8	90,4	50
55	114,3	114,3	114,1	113,6	113,1	112,5	111,9	111,3	110,7	109,6	103,4	89,0	55
60	101,7	101,7	101,6	101,0	100,5	99,9	99,3	98,6	98,0	97,3	95,5	87,9	60
65	91,2	91,4	91,3	90,7	90,2	89,5	88,9	88,2	87,6	86,8	86,1	83,5	65
85		63,7	63,7	63,2	62,7	62,0	61,3	60,5	59,8	59,0	58,3	57,5	85
105			47,5	47,2	46,7	45,9	45,3	44,5	43,7	42,9	42,1	41,3	105
125				36,5	36,1	35,4	34,8	33,9	33,2	32,3	31,5	30,7	125
145					28,5	28,0	27,3	26,6	25,9	25,1	24,3	23,4	145
165						22,4	21,9	21,1	20,4	19,5	18,7	17,8	165
180							18,5	17,8	17,0	16,2	15,4	14,5	180
200								14,1	13,4	12,6	11,8	10,9	200
220									10,4	9,6	8,8	7,9	220
240										7,1	6,3	5,5	240
260											4,2	3,4	260
270												2,4	270

TLT 10576488 - M133451 Offiziell

Lift chart for main boom (No. 2320.xx)

159,400 lbs counterweight and 79,400 lbs carbody counterweight

Capacities in 1000 lbs for boom lengths (66 ft - 272 ft) – with 26,980 lbf winches

Radius (ft)	Boom length in (ft)												Radius (ft)
	66 lbs	85 lbs	105 lbs	125 lbs	144 lbs	164 lbs	184 lbs	203 lbs	223 lbs	243 lbs	262 lbs	272 lbs	
13,4	550,0*												13,4
15	484,9	434,1											15
20	415,7	395,0	363,3	318,4	279,9								20
25	334,4	334,8	320,8	297,5	270,7	234,9	202,8	174,4	148,3				25
30	248,3	248,5	248,6	248,4	244,9	224,2	195,7	170,1	147,0	127,7	111,4	101,9	30
35	196,6	196,7	196,6	196,3	196,1	195,0	187,1	166,1	145,1	125,4	109,8	101,0	35
45	137,4	137,4	137,3	136,8	136,4	135,9	135,4	134,8	131,3	121,2	106,5	98,5	45
50	118,9	118,9	118,7	118,2	117,8	117,2	116,6	116,0	115,1	111,9	104,8	96,9	50
55	104,4	104,4	104,2	103,7	103,2	102,6	102,1	101,4	100,8	99,1	96,3	94,9	55
60	92,8	92,9	92,7	92,1	91,6	91,0	90,4	89,7	89,1	88,4	86,0	84,7	60
65	83,1	83,4	83,2	82,6	82,1	81,5	80,8	80,1	79,5	78,7	77,4	76,2	65
70	26,6	75,4	75,3	74,7	74,2	73,5	72,9	72,2	71,5	70,7	70,0	69,0	70
85		57,8	57,8	57,3	56,7	56,0	55,4	54,6	53,9	53,1	52,3	51,9	85
105			42,8	42,5	42,0	41,2	40,6	39,8	39,0	38,2	37,4	37,0	105
125				32,6	32,3	31,6	30,9	30,1	29,3	28,5	27,7	27,3	125
145					25,4	24,8	24,2	23,4	22,6	21,8	21,0	20,6	145
165						19,5	19,0	18,2	17,5	16,6	15,8	15,4	165
180							15,9	15,1	14,4	13,6	12,8	12,4	180
200								11,7	11,0	10,2	9,4	9,0	200
220									8,2	7,5	6,7	6,3	220
240										5,1	4,4	4,0	240
260											2,4	2,0	260

TLT 10576488 - M133451 Offiziell

Above lift chart is for reference only. For actual lift duty please refer to lift chart in operator's cab or manual.

*) Capacities over 485,0 lbs require a special heavy duty boom head.

L-boom high reach (No. 2320/1916.xx) 216 ft - 384 ft

Working range 84° - 15°

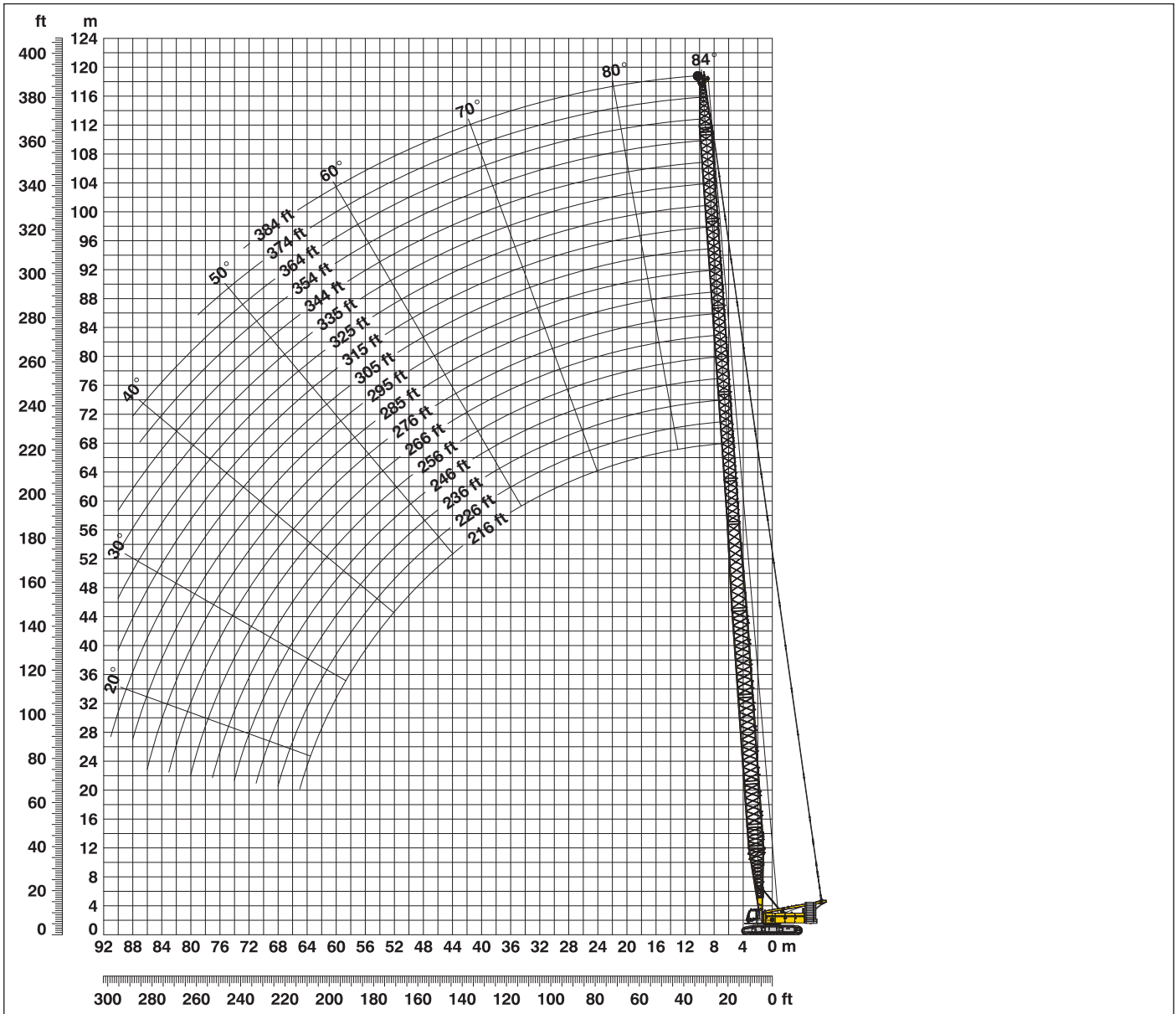

L-boom configuration with 141 ft main boom (No. 2320.xx/1916.xx)

Configuration for L-boom lengths (216 ft - 384 ft)

Length*	Amount of boom and luffing jib extensions																		
	33 ft	43 ft	53 ft	63 ft	73 ft	83 ft	93 ft	103 ft	113 ft	123 ft	133 ft	143 ft	153 ft	163 ft	173 ft	183 ft	193 ft	203 ft	213 ft
Boom foot	1	1	1	1	1	1	1	1	1	1	1	1	1	1	1	1	1	1	1
Boom insert	1	1	1	1	1	1	1	1	1	1	1	1	1	1	1	1	1	1	1
Boom insert	1	1	1	1	1	1	1	1	1	1	1	1	1	1	1	1	1	1	1
Boom insert	2	2	2	2	2	2	2	2	2	2	2	2	2	2	2	2	2	2	2
Tapered	1	1	1	1	1	1	1	1	1	1	1	1	1	1	1	1	1	1	1
Luffing insert	1		1		1		1		1		1		1		1		1		1
Luffing insert		1	1			1	1			1	1			1	1			1	1
Luffing insert				1	1	1	1	2	2	2	2	3	3	3	3	4	4	4	4
Luffing jib head	1	1	1	1	1	1	1	1	1	1	1	1	1	1	1	1	1	1	1
Max. L-boom length (ft)	216	226	236	246	256	266	276	285	295	305	315	325	335	344	354	364	374	384	

*Actual lengths of boom sections are metric (e.g. 3m, 6m, 8m, 10m, 12m). The figures shown above are approximate conversions to feet.

Lift chart for L-boom (No. 2320/1916.xx)

Main boom length 141 ft

Capacities in 1000 lbs 181,400 lbs counterweight and 79,400 lbs carbody counterweight						
Radius	Boom length in (ft)					
	217	246	295	325	354	384
(ft)	lbs	lbs	lbs	lbs	lbs	lbs
29	139,8					
35	139,3	99,9				
40	130,1	97,2	61,6			
45	121,7	94,0	59,4	45,0	35,4	
50	108,0	91,1	56,6	43,3	34,1	26,1
55	98,4	87,0	54,5	41,4	32,7	25,5
60	89,5	84,0	52,0	39,9	31,4	24,2
65	81,9	79,4	49,5	38,2	30,4	23,2
70	76,1	73,7	47,5	36,5	29,2	22,5
75	70,8	69,0	45,8	35,0	27,9	21,5
80	65,6	65,7	43,7	33,9	26,8	20,7
85	61,4	61,0	42,0	32,5	26,0	19,9
90	58,1	56,7	40,5	31,3	25,1	19,3
100	51,0	50,0	37,8	29,2	23,3	18,0
110	45,2	44,7	35,2	27,4	22,0	16,8
120	40,1	39,8	33,3	25,6	20,7	15,9
130	35,8	35,7	30,9	24,2	19,4	15,0
140	32,1	32,0	28,6	22,9	18,4	14,1
150	29,0	28,9	26,9	21,6	17,5	13,3
160	26,3	26,3	25,4	20,6	16,5	12,7
170	23,9	23,9	23,0	19,7	15,6	11,9
180	21,8	21,7	20,9	18,3	14,9	11,3
190	19,9	19,9	19,1	17,1	14,1	10,7
200	18,2	18,2	17,4	16,0	13,2	10,3
210	16,6	16,6	15,8	15,1	12,4	9,5
215	15,9	15,9	15,1	14,4	12,0	9,2
240		12,8	12,1	11,6	9,8	7,8
290			7,1	6,8	4,8	3,5
310				4,9	2,9	2,4
315				4,4	2,5	2,2
320				4,0	2,2	
325					2,0	

TLT 10576488 - M133451 Offiziell

Main boom length 180 ft

Capacities in in 1000 lbs 181,400 lbs counterweight and 79,400 lbs carbody counterweight						
Radius	Boom length in (ft)					
	256	295	315	335	354	374
(ft)	lbs	lbs	lbs	lbs	lbs	lbs
33,5	109,1					
40	106,7	75,1	65,5			
45	103,2	73,3	63,6	52,5	43,7	
50	100,8	71,0	61,7	50,8	42,1	35,3
55	92,9	69,4	59,5	48,5	40,6	34,3
60	86,1	67,6	57,9	46,7	39,0	32,7
65	81,1	65,8	55,6	45,2	37,7	31,5
70	73,8	64,4	53,5	43,1	36,4	30,6
75	67,6	62,6	51,8	41,4	34,9	29,4
80	62,7	58,2	50,3	40,0	33,6	28,3
85	58,8	54,4	48,2	38,7	32,5	27,3
90	54,4	51,2	46,4	37,3	31,5	26,6
100	47,3	45,9	43,7	35,0	29,4	24,9
110	42,5	40,1	39,2	33,2	27,8	23,4
120	37,5	35,8	34,6	30,7	26,4	22,4
130	33,7	31,8	31,2	28,7	25,0	21,0
140	30,5	28,2	27,6	27,2	23,9	19,9
150	27,3	25,4	24,4	24,0	22,6	19,0
160	24,7	24,1	22,1	21,3	20,0	17,6
170	22,3	22,0	20,7	19,4	17,9	15,9
180	20,2	19,8	19,0	17,8	16,2	14,4
190	18,3	18,0	17,5	16,4	14,8	13,2
200	16,6	16,3	16,0	15,1	13,5	12,0
210	15,1	14,7	14,4	14,1	12,3	10,9
220	13,7	13,4	13,0	12,9	11,4	9,9
230	12,4	12,1	11,6	11,3	10,6	9,1
240	11,2	10,9	10,4	9,9	9,0	8,3
250	10,1	9,8	9,2	8,7	7,6	6,8
290		5,3	5,0	4,6	3,3	2,4
300			4,1	3,9	2,4	2,1
310			3,3	2,9		
315				2,5		

TLT 10576488 - M133451 Offiziell

Above lift chart is for reference only. For actual lift duty please refer to lift chart in operator's cab or manual.

L-boom configuration with 180 ft main boom (No. 2320.xx/1916.xx)

Configuration for L-boom lengths (256 ft - 374 ft)														
	Length*	Amount of boom and luffing jib extensions												
		1	1	1	1	1	1	1	1	1	1	1	1	1
Boom foot	33 ft	1	1	1	1	1	1	1	1	1	1	1	1	1
Boom insert	10 ft	1	1	1	1	1	1	1	1	1	1	1	1	1
Boom insert	20 ft	1	1	1	1	1	1	1	1	1	1	1	1	1
Boom insert	40 ft	3	3	3	3	3	3	3	3	3	3	3	3	3
Tapered	40 ft	1	1	1	1	1	1	1	1	1	1	1	1	1
Luffing insert	10 ft	1		1		1		1		1		1		1
Luffing insert	20 ft		1	1			1	1			1	1		
Luffing insert	40 ft				1	1			2	2		2	3	3
Luffing jib head	26 ft	1	1	1	1	1	1	1	1	1	1	1	1	1
Max. L-boom length (ft)		256	266	276	285	295	305	315	325	335	344	354	364	374

*Actual lengths of boom sections are metric (e.g. 3m, 6m, 8m, 10m, 12m). The figures shown above are approximate conversions to feet.

Lift chart - luffing jib (No.1916.xx)

Main boom 88°

Main boom 76 ft

Radius	Jib length in (ft)							
	66	95	135	174	203	233	272	312
(ft)	lbs	lbs	lbs	lbs	lbs	lbs	lbs	lbs
26	155,8							
35	155,8	148,7						
45	142,2	132,3	97,0					
50	128,8	121,8	93,5	69,2				
55	118,8	112,6	89,2	67,9	52,8			
65	100,4	97,2	81,8	65,0	50,8	38,9		
70	85,8	91,0	78,0	63,6	49,9	38,2	26,7	
75	26,6	84,0	75,1	62,6	48,7	37,8	26,5	
100		54,8	57,6	56,1	44,4	34,6	23,8	16,3
140			34,4	37,9	37,3	30,2	20,5	13,5
180				23,3	26,7	25,9	18,1	11,4
205					20,0	21,6	16,9	10,4
235						15,0	15,8	9,1
275							9,5	7,4
310								5,3

Main boom 115 ft

Radius	Jib length in (ft)							
	66	95	135	174	203	233	272	312
(ft)	lbs	lbs	lbs	lbs	lbs	lbs	lbs	lbs
27,4	155,8							
35	155,8	130,6						
45	151,2	124,8	89,1					
50	140,0	120,6	86,6	61,3				
60	111,1	110,8	81,3	60,2	46,0			
65	100,5	100,3	78,5	59,3	45,5	35,1		
75	80,6	84,1	73,3	57,7	44,4	34,3	24,7	
105		26,6	55,2	51,9	40,7	31,7	22,1	15,0
140			38,1	37,9	36,7	28,6	19,6	12,9
180				26,6	26,7	25,7	17,3	11,0
205					22,0	21,6	16,3	10,0
235						16,8	15,3	8,9
275							10,7	7,5
305								6,4
310								6,2

Main boom 144 ft

Radius	Jib length in (ft)							
	66	95	135	174	203	233	272	312
(ft)	lbs	lbs	lbs	lbs	lbs	lbs	lbs	lbs
28,4	143,3							
35	141,9	112,1						
45	132,0	107,4	77,1					
55	119,5	100,6	73,9	53,8				
60	111,1	97,7	72,3	53,0	41,1			
65	100,6	93,5	70,6	52,2	40,6	32,1		
75	83,4	84,1	66,6	50,5	39,5	31,4	23,0	
85		72,2	62,5	48,4	38,4	30,7	22,4	15,4
105		55,7	54,5	44,8	36,0	29,1	21,1	14,2
140			38,6	37,9	31,9	26,2	18,8	12,3
180				27,2	26,6	23,3	16,7	10,5
210					21,2	20,8	15,6	9,4
235						17,1	14,9	8,5
275							11,2	7,2
315								5,6

Main boom 174 ft

Radius	Jib length in (ft)							
	66	95	135	174	203	233	272	312
(ft)	lbs	lbs	lbs	lbs	lbs	lbs	lbs	lbs
29,4	118,8							
40	111,2	89,2						
45	107,0	86,5	64,3					
55	98,2	81,0	61,9	46,2				
60	94,4	78,6	60,4	45,5	36,5			
65	90,5	75,7	59,2	44,8	36,3	28,7		
75	81,3	70,5	55,9	43,1	35,1	28,2	20,7	
85		65,5	52,9	41,4	34,0	27,4	20,4	14,1
105		55,6	47,2	38,0	31,7	25,9	19,3	13,3
145			26,6	31,5	27,4	22,7	17,3	11,3
180				27,0	23,8	20,3	15,6	9,9
210					20,8	18,4	14,4	8,9
240						15,9	13,4	7,9
275							11,1	6,9
315								5,4

Main boom 184 ft

Radius	Jib length in (ft)							
	66	95	115	135	174	203	233	243
(ft)	lbs	lbs	lbs	lbs	lbs	lbs	lbs	lbs
29,8	109,1							
40	102,7	83,6	71,5					
45	98,6	81,1	70,4	60,8				
55	90,8	76,0	66,9	58,6	44,1			
60	87,5	73,7	65,0	57,1	43,5	34,8		
65	84,0	71,1	62,9	56,0	42,9	34,6	27,6	
70	81,1	68,5	61,4	54,3	41,9	34,0	27,6	25,5
75	77,5	66,3	59,3	52,8	41,1	33,5	27,2	25,3
105		54,4	48,9	44,7	36,2	30,1	24,9	23,3
125			43,8	39,7	33,1	27,9	23,4	21,8
145				26,6	29,9	25,9	21,8	20,5
180					25,9	22,5	19,4	18,4
210						20,2	17,6	16,6
240							15,8	15,1
250								14,6

Main boom 194 ft

Radius	Jib length in (ft)					
	66	95	115	135	164	
(ft)	lbs	lbs	lbs	lbs	lbs	
30,1	101,2					
40	95,8	77,6				
45	91,8	75,4	65,9	57,0		
55	84,8	70,7	62,5	55,1	45,0	
60	81,9	68,6	60,8	53,6	44,3	
65	78,7	66,2	58,8	52,6	43,5	
70	76,2	63,8	57,4	50,9	42,5	
75	74,3	61,8	55,5	49,5	41,8	
105		51,7	45,8	42,0	36,2	
125			41,7	37,3	32,9	
140				35,1	30,3	
145				34,3	29,6	
160					28,0	
165					27,5	
170					27,0	

Capacities in 1000 lbs with luffing jib (No. 1916.xx), 181,440 lbs counterweight + 79,400 lbs carbody counterweight. Above lift chart is for reference only. For actual lift duty and complete chart with all available configurations please refer to lift chart in operator's cab or manual.

TLT 10576488 - M133451 Offiziell

Lift chart - luffing jib (No. 1916.xx)

Main boom 83°

Main boom 76 ft

Radius	Jib length in (ft)							
	66	95	135	174	203	233	272	312
(ft)	lbs	lbs	lbs	lbs	lbs	lbs	lbs	lbs
37	155,8							
50	136,9	136,4						
60	108,6	108,2	92,9					
70	89,7	89,4	84,5	67,4				
80	26,6	75,9	75,1	64,4	50,0			
90		65,7	65,0	60,4	48,0	37,8		
100		57,8	57,1	56,2	46,3	36,4	25,0	
105		51,6	53,8	52,9	45,5	35,8	24,6	
110			50,8	49,9	44,8	35,0	24,1	15,9
145			32,4	34,8	33,4	29,8	21,0	13,7
185				22,0	25,0	23,4	18,5	11,7
210					18,5	20,0	16,5	10,6
240						13,4	14,8	9,2
280							8,3	7,3
315								4,6

Main boom 115 ft

Radius	Jib length in (ft)							
	66	95	135	174	203	233	272	312
(ft)	lbs	lbs	lbs	lbs	lbs	lbs	lbs	lbs
43	155,8							
55	119,1	118,4						
65	96,6	96,0	84,5					
75	81,0	80,5	79,6	59,9				
85	69,3	69,1	68,2	58,4	44,9			
95		60,3	59,5	56,4	43,7	34,1		
105		53,4	52,6	51,7	42,4	33,0	22,8	
115		26,6	47,1	46,1	41,1	32,1	22,1	14,7
150			33,7	32,9	32,2	28,9	19,6	12,9
190				23,9	23,4	22,6	17,4	11,0
220					18,8	18,1	16,2	10,0
245						15,2	14,3	8,9
285							10,8	7,6
315								6,6
320								6,4

Main boom 144 ft

Radius	Jib length in (ft)							
	66	95	135	174	203	233	272	312
(ft)	lbs	lbs	lbs	lbs	lbs	lbs	lbs	lbs
46,6	141,6							
60	105,2	104,5						
70	86,9	86,3	75,9					
80	73,8	73,3	72,3	53,9				
90	26,6	63,5	62,5	52,8	40,8			
100		55,8	55,0	51,1	40,0	31,5		
110		49,6	48,9	47,9	38,9	30,8	21,5	
115		47,0	46,3	45,3	38,3	30,4	21,3	
120			43,9	42,9	37,8	30,0	21,0	13,8
155			31,7	30,9	30,2	27,3	18,8	12,1
195				22,6	22,0	21,2	16,8	10,5
220					18,4	17,7	15,9	9,6
250						14,3	13,4	8,5
290							10,0	7,3
325								6,3

Main boom 174 ft

Radius	Jib length in (ft)							
	66	95	135	174	203	233	272	312
(ft)	lbs	lbs	lbs	lbs	lbs	lbs	lbs	lbs
50,2	115,1							
60	103,5	89,4						
75	78,5	77,8	63,5					
90	62,7	62,3	59,5	45,4				
95		58,3	57,4	44,8	36,1			
100		54,8	53,9	44,1	35,7	28,2		
115		46,1	45,3	42,0	34,3	27,6	19,6	
120		43,7	43,0	41,0	33,8	27,3	19,5	
125			40,9	39,8	33,4	26,9	19,2	12,8
160			26,6	28,9	28,2	24,4	17,4	11,3
195				22,1	21,5	20,7	15,8	10,0
225					17,3	16,6	14,8	9,1
255						13,4	12,5	8,0
290							9,7	7,1
330								5,6

Main boom 184 ft

Radius	Jib length in (ft)							
	66	95	115	135	174	203	233	243
(ft)	lbs	lbs	lbs	lbs	lbs	lbs	lbs	lbs
51,4	106,3							
65	93,1	82,2						
70	84,9	80,0	70,0					
75	78,0	77,3	68,5	59,9				
85	66,9	66,4	65,1	57,7	43,7			
95	26,6	58,0	57,4	55,1	42,7	34,3		
105		51,3	50,8	50,4	41,2	33,6	27,1	24,9
120		43,4	43,1	42,7	39,1	32,1	26,3	24,4
135			37,2	36,8	35,8	30,8	25,3	23,5
140			35,5	35,2	34,2	30,2	25,0	23,2
160				29,5	28,7	28,0	23,5	22,0
200					21,1	20,5	19,7	19,5
225						17,2	16,4	16,2
255							13,3	13,1
265								12,2

Main boom 194 ft

Radius	Jib length in (ft)					
	66	95	115	135	164	
(ft)	lbs	lbs	lbs	lbs	lbs	
52,6	99,1					
65	92,5	76,7				
70	84,4	74,5	65,4			
75	77,5	72,3	64,0	56,1		
85	66,5	65,9	60,8	54,2	44,6	
90	62,0	61,5	59,5	52,8	44,0	
95	57,9	57,6	57,0	51,7	43,3	
120		43,1	42,8	42,4	39,1	
125		26,6	40,7	40,3	38,2	
135			36,9	36,5	35,9	
140			35,2	34,9	34,2	
155				30,6	30,0	
160				29,3	28,7	
185					23,7	
190					22,8	

TLT 10576488 - M133451 Offiziell

Capacities in 1000 lbs with luffing jib (No. 1916.xx), 181,440 lbs counterweight + 79,400 lbs carbody counterweight. Above lift chart is for reference only. For actual lift duty and complete chart with all available configurations please refer to lift chart in operator's cab or manual.

Lift chart - luffing jib (No. 1916.xx)

Main boom 75°

Main boom 76 ft

Radius	Jib length in (ft)							
	66	95	135	174	203	233	272	312
(ft)	lbs	lbs	lbs	lbs	lbs	lbs	lbs	lbs
57,1	53,0							
70	86,0	85,3						
90	63,1	62,7	61,8					
105		52,0	51,1	50,1				
120		44,0	43,3	42,3	41,6			
130			39,2	38,2	37,5	32,5		
145			34,1	33,2	32,5	31,3	20,9	
155			31,3	30,5	29,7	28,9	20,5	
165				28,0	27,3	26,5	19,7	12,8
195				22,3	21,7	20,9	18,0	11,2
220					18,1	17,4	16,3	10,2
250						14,1	13,1	9,1
290							9,8	7,9
325								6,5
330								5,8

Main boom 115 ft

Radius	Jib length in (ft)							
	66	95	135	174	203	233	272	312
(ft)	lbs	lbs	lbs	lbs	lbs	lbs	lbs	lbs
67,3	53,0							
80	70,0	69,1						
100	53,1	52,7	51,6					
115		44,4	43,4	42,2				
130		38,0	37,2	36,1	35,3			
140			33,9	32,8	32,0	30,4		
155			29,7	28,7	27,9	27,0	19,6	
165			27,3	26,4	25,7	24,8	19,3	
175				24,4	23,7	22,8	18,7	12,1
205				19,5	18,8	18,0	16,8	10,7
235					15,2	14,4	13,4	9,7
260						12,1	11,1	8,9
300							8,1	7,1
335								5,2
340								4,9

Main boom 144 ft

Radius	Jib length in (ft)							
	66	95	135	174	203	233	272	312
(ft)	lbs	lbs	lbs	lbs	lbs	lbs	lbs	lbs
74,9	53,0							
90	58,2	57,3						
105	48,1	47,5	46,3					
110	26,6	44,8	43,7					
125		38,3	37,2	36,0				
135		34,7	33,8	32,6	31,8			
150			29,5	28,4	27,6	26,6		
165			26,1	25,0	24,2	23,2	18,6	
175			24,0	23,1	22,3	21,3	18,4	
180				22,2	21,4	20,5	18,1	11,4
215				17,1	16,4	15,5	14,4	10,2
240					13,7	12,9	11,8	9,4
270						10,3	9,3	7,8
310							6,7	5,5
345								3,9

Main boom 174 ft

Radius	Jib length in (ft)							
	66	95	135	174	203	233	272	312
(ft)	lbs	lbs	lbs	lbs	lbs	lbs	lbs	lbs
82,6	53,0							
100	48,8	47,9						
115	40,9	40,3	39,1					
130		34,6	33,4	32,2				
145		30,0	29,1	27,8	27,0			
155			26,6	25,5	24,7	23,0		
170			23,6	22,5	21,7	20,3	17,2	
180			21,8	20,7	19,9	18,7	16,5	
190				19,2	18,4	17,3	15,1	10,6
215				15,9	15,2	14,3	12,3	9,9
220					15,3	14,7	13,7	11,8
250						11,8	10,9	9,3
275							9,0	7,7
315								5,6
355								2,4

Main boom 184 ft

Radius	Jib length in (ft)							
	66	95	115	135	174	203	233	243
(ft)	lbs	lbs	lbs	lbs	lbs	lbs	lbs	lbs
85,1	53,0							
100	47,9	46,9						
110	42,6	41,7	41,0					
115	40,2	39,5	38,8	38,2				
120	26,6	37,5	36,8	36,2				
135		32,3	31,7	31,2	29,9			
145		29,4	28,9	28,4	27,2	26,1		
160			25,4	25,0	23,8	23,0	21,1	20,6
165			24,4	24,0	22,8	22,0	20,2	19,8
180				21,3	20,2	19,4	17,8	17,4
185				20,4	19,4	18,6	17,1	16,7
225					14,4	13,7	12,7	12,3
250						11,4	10,5	10,3
280							8,3	8,2
290								7,5

Main boom 194 ft

Radius	Jib length in (ft)					
	66	95	115	135	164	
(ft)	lbs	lbs	lbs	lbs	lbs	
87,7	53,0					
105	44,3	43,3				
110	41,8	40,9	40,2			
120	37,4	36,7	36,0	35,4		
130		33,2	32,6	32,0	31,1	
145		28,8	28,3	27,8	26,9	
150		27,5	27,1	26,6	25,8	
165			23,9	23,4	22,7	
170			22,9	22,5	21,7	
180				20,8	20,1	
185				20,0	19,3	
195					17,9	
205					16,6	
210					16,0	
215					15,4	

TLT 10576488 - M133451 Offiziell

Capacities in 1000 lbs with luffing jib (No. 1916.xx), 181,440 lbs counterweight + 79,400 lbs carbody counterweight. Above lift chart is for reference only. For actual lift duty and complete chart with all available configurations please refer to lift chart in operator's cab or manual.

Lift chart - luffing jib (No. 1916.xx)

Main boom 65°

Main boom 76 ft

Radius	Jib length in (ft)							
	66	95	135	174	203	233	272	312
(ft)	lbs	lbs	lbs	lbs	lbs	lbs	lbs	lbs
79,2	53,0							
100	52,8	52,2						
105	26,6	49,2						
120		41,7	40,7					
130		37,7	36,9					
145			32,1	31,0				
160			28,2	27,2	26,5			
170			26,0	25,1	24,4			
180				23,2	22,5	21,6		
200				20,0	19,3	18,4	17,3	
205				19,3	18,6	17,7	16,6	
235					15,0	14,2	13,1	10,2
265						11,4	10,5	9,1
305							7,7	6,7
340								4,8

Main boom 115 ft

Radius	Jib length in (ft)							
	66	95	135	174	203	233	272	312
(ft)	lbs	lbs	lbs	lbs	lbs	lbs	lbs	lbs
95,8	51,3							
115	41,0	40,2						
120	38,8	38,1						
140		31,4	30,3					
150		26,6	27,7					
160			25,5	24,3				
175			22,6	21,5	20,6			
185			20,9	19,8	19,0			
195				18,4	17,6	16,6		
215				15,9	15,1	14,1	12,9	
225				14,7	14,1	13,1	11,9	
255					11,3	10,4	9,3	7,7
280						8,6	7,5	6,1
320							5,2	4,0
355								2,6

Main boom 144 ft

Radius	Jib length in (ft)							
	66	95	135	184	203	233	272	312
(ft)	lbs	lbs	lbs	lbs	lbs	lbs	lbs	lbs
108,3	40,8							
130	32,4	31,6						
150		26,3	25,1					
160		24,1	23,1					
180			19,6	18,1				
190			18,1	16,7	16,1			
200			16,8	15,5	14,9			
205				14,9	14,3	13,2		
230				12,3	11,8	10,8	9,0	
245				11,0	10,5	9,5	7,9	
250					10,1	9,1	7,5	5,5
265					9,0	8,1	6,6	4,6
295						6,3	5,0	3,1
320							3,9	2,1
330							3,5	

Main boom 174 ft

Radius	Jib length in (ft)							
	66	95	135	174	203	233	272	312
(ft)	lbs	lbs	lbs	lbs	lbs	lbs	lbs	lbs
120,8	32,3							
140	26,7	25,8						
145	25,5	24,7						
165		20,7	19,5					
175		19,0	18,0					
185			16,6	15,3				
200			14,7	13,5	12,4			
210			13,6	12,5	11,5			
220				11,5	10,7	8,9		
240				9,9	9,1	7,5	5,4	
250				9,1	8,4	6,9	4,8	
265					7,4	6,0	4,0	2,0
280					6,5	5,3	3,3	
305						4,2	2,3	
310							2,1	

Main boom 184 ft

Radius	Jib length in (ft)							
	66	95	115	135	174	203	233	243
(ft)	lbs	lbs	lbs	lbs	lbs	lbs	lbs	lbs
124,9	29,8							
145	24,6	23,6						
150	23,4	22,6						
155		21,6	20,9					
165		19,8	19,2	18,5				
175		18,2	17,6	17,1				
190			15,6	15,1	13,8			
195			15,0	14,5	13,2			
205				13,4	12,2	10,8		
215				12,4	11,2	10,0		
230					10,0	8,9	7,1	6,8
255					8,1	7,3	5,6	5,3
280						5,9	4,4	4,1
310							3,3	3,0
320								2,6

Main boom 194 ft

Radius	Jib length in (ft)							
	66	95	115	135	164			
(ft)	lbs	lbs	lbs	lbs	lbs			
129,1	27,4							
150	22,5	21,6						
155	21,4	20,6						
160		19,7	19,0					
170		18,1	17,5	16,8				
180		16,7	16,1	15,5				
190			14,8	14,3	13,4			
195			14,2	13,7	12,9			
200			13,7	13,2	12,3			
205				12,7	11,9			
210				12,2	11,4			
220				11,2	10,5			
230					9,7			
240					9,0			
250					8,2			

TLT 10576488 - M133451 Offiziell

Capacities in 1000 lbs with luffing jib (No. 1916.xx), 181,440 lbs counterweight + 79,400 lbs carbody counterweight. Above lift chart is for reference only. For actual lift duty and complete chart with all available configurations please refer to lift chart in operator's cab or manual.

Lift chart - luffing jib (No. 1916.xx)

Main boom 45°

Main boom 76 ft

Radius	Jib length in (ft)							
	66	95	135	174	203	233	272	312
(ft)	lbs	lbs	lbs	lbs	lbs	lbs	lbs	lbs
116	39,9							
125	36,3							
141		30,6						
155		26,6						
175			22,1					
190			19,7					
205				16,6				
230				13,8	13,1			
255					10,9	10,0		
260					10,5	9,7		
285						7,9		
290							6,6	
320							4,9	3,8
325							4,7	3,6
360								2,1

Main boom 115 ft

Radius	Jib length in (ft)						
	66	95	144	174	203	233	272
(ft)	lbs	lbs	lbs	lbs	lbs	lbs	lbs
143,9	25,7						
150	24,3						
168		20,0					
180		18,2					
210			13,2				
230			11,4				
235				10,1			
255				8,6			
260					7,5		
285					6,0	5,0	
315						3,6	2,2
320							2,1

Main boom 144 ft

Radius	Jib length in (ft)				
	66	95	135	174	203
(ft)	lbs	lbs	lbs	lbs	lbs
164,7	17,8				
175	16,3				
190		13,6			
200		12,5			
223			9,3		
240			8,1		
255				5,9	
280				4,7	3,9
305					2,8

Main boom 174 ft

Radius	Jib length in (ft)			
	66	95	135	
(ft)	lbs	lbs	lbs	
185,6	11,4			
190	11,0			
195	10,5			
210		8,3		
220		7,6		
225		7,3		
242			5,0	
250			4,7	
260			4,2	

Main boom 184 ft

Radius	Jib length in (ft)			
	66	95	115	135
(ft)	lbs	lbs	lbs	lbs
192,6	9,5			
200	8,9			
220		6,5		
230		5,9		
235			4,9	
250			4,1	3,5
270				2,7

Main boom 194 ft

Radius	Jib length in (ft)		
	66	95	115
(ft)	lbs	lbs	lbs
199,5	7,7		
210	6,9		
225		5,1	
235		4,5	
240			3,4
245			3,2
255			2,9

TLT 10576488 - M133451 Offiziell

Capacities in 1000 lbs with luffing jib (No. 1916.xx), 181,440 lbs counterweight + 79,400 lbs carbody counterweight. Above lift chart is for reference only. For actual lift duty and complete chart with all available configurations please refer to lift chart in operator's cab or manual.

Working range - fixed jib (No. 1008.xx) 15° and 30°

Main boom 88° - 30°

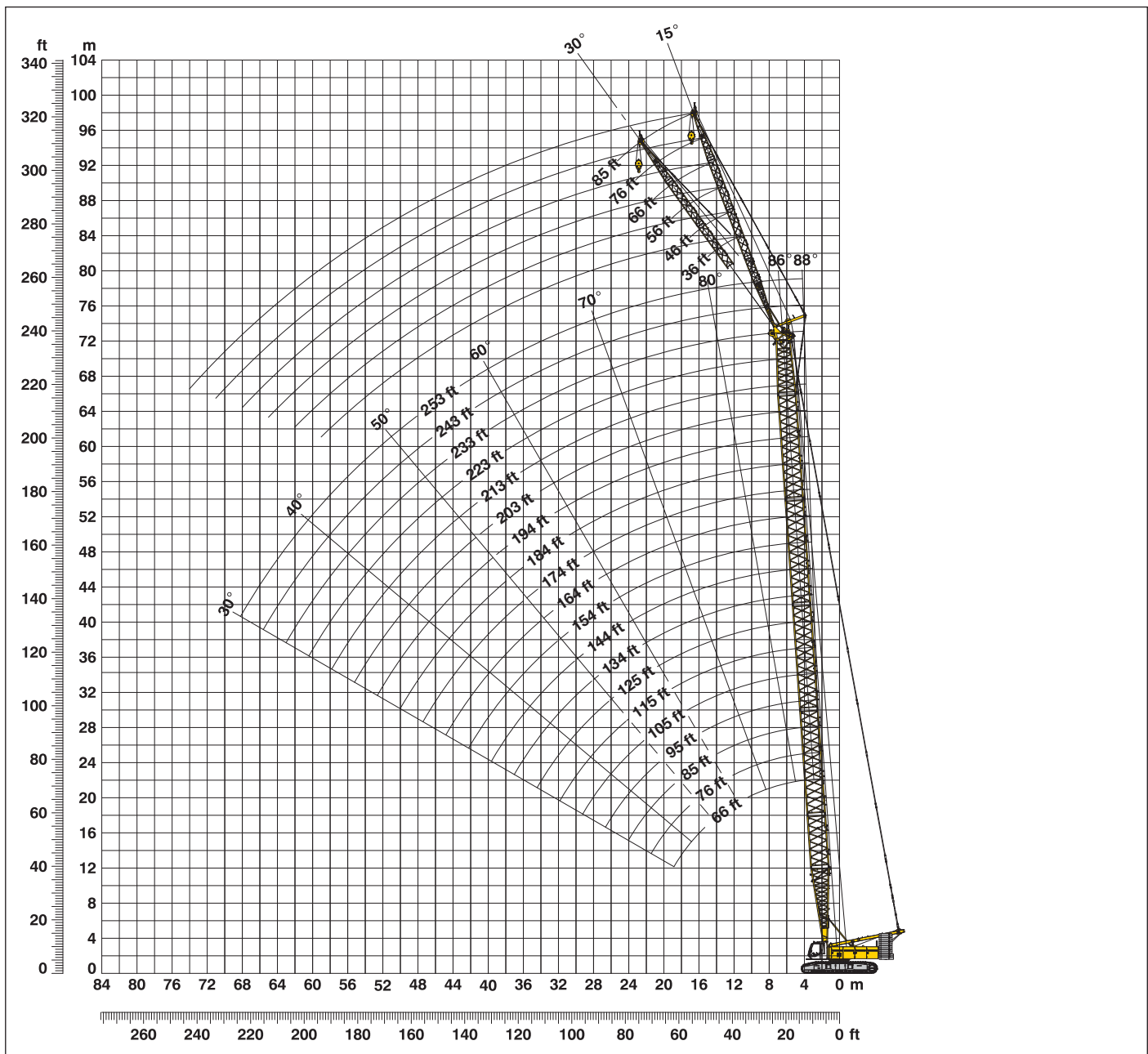

Boom configuration for boom lengths (66 ft - 243 ft) – see table 1 on page 10

Fixed jib configuration for fixed jib lengths (36 ft - 85 ft)

	Length*	Amount of fixed jib extensions					
Fixed jib foot	18 ft	1	1	1	1	1	1
Fixed jib insert	10 ft		1		1		1
Fixed jib insert	20 ft			1	1	2	2
Fixed jib head	18 ft	1	1	1	1	1	1
Fixed jib length (ft)		36	46	46	66	76	85

*Actual lengths of boom sections are metric (e.g. 3m, 5.5 m, 6m). The figures shown above are approximate conversions to feet.

Lift chart - fixed jib (No. 1008.xx)

Offset 15°

Main boom 66 ft

Radius	Fixed jib length in (ft)			
	36	46	66	85
(ft)	lbs	lbs	lbs	lbs
30	79,1	79,1		
35	79,1	77,4	68,8	
40	79,1	75,2	66,4	52,1
50	78,9	69,3	58,1	47,8
60	77,9	64,3	50,2	41,8
70	71,8	60,0	45,9	36,8
80	63,5	53,8	40,6	32,8
100	52,5	45,9	33,3	26,8
110		42,1	30,6	25,2
125			27,5	22,5
145				19,8

Main boom 95 ft

Radius	Fixed jib length in (ft)			
	36	46	66	85
(ft)	lbs	lbs	lbs	lbs
25	79,1			
30	79,1	79,1		
35	79,1	79,1	70,4	
40	79,1	77,1	68,3	52,2
50	79,1	73,1	61,9	47,9
70	77,8	64,5	48,8	39,7
90	59,6	57,1	41,3	32,5
125	37,5	38,2	31,5	25,4
135		34,0	29,7	23,9
155			26,8	21,5
170				19,9

Main boom 125 ft

Radius	Fixed jib length in (ft)			
	36	46	66	85
(ft)	lbs	lbs	lbs	lbs
20,7	79,1			
25	79,1	79,1		
30	79,1	79,1		
35	79,1	79,1	70,8	
40	79,1	79,1	69,9	51,7
70	78,8	69,1	53,7	41,3
110	44,0	44,6	39,6	30,0
150	27,2	27,8	28,8	24,2
160		24,9	25,9	23,1
180			21,1	21,1
200				18,0

Main boom 154 ft

Radius	Fixed jib length in (ft)			
	36	46	66	85
(ft)	lbs	lbs	lbs	lbs
21,7	79,1			
30	79,1	79,1		
35	79,1	79,1	68,9	
45	79,1	78,8	67,0	50,5
60	79,1	73,7	60,8	45,8
100	49,3	50,0	45,6	34,1
140	29,4	29,9	31,0	26,7
175	19,7	20,2	21,1	21,9
185		18,1	19,0	19,8
205			15,3	16,1
225				13,1

Main boom 184 ft

Radius	Fixed jib length in (ft)			
	36	46	66	85
(ft)	lbs	lbs	lbs	lbs
22,7	79,1			
30	79,1	79,1		
35	79,1	79,1	68,5	
45	79,1	79,0	67,0	47,9
80	66,5	67,4	55,0	40,3
120	36,3	37,0	38,2	31,8
160	22,1	22,6	23,6	24,5
200	13,6	14,1	15,0	15,8
210		12,5	13,4	14,1
230			10,5	11,2
250				8,8

Main boom 203 ft

Radius	Fixed jib length in (ft)			
	36	46	66	85
(ft)	lbs	lbs	lbs	lbs
23,4	79,1			
30	79,1	79,1		
35	79,1	79,0	66,9	
45	79,1	78,3	65,6	46,6
60	79,1	75,6	63,1	44,5
100	47,3	48,1	49,1	36,8
140	27,2	27,8	29,0	29,5
215	10,5	10,9	11,8	12,5
225		9,5	10,3	11,1
245			7,8	8,6
265				6,3

Main boom 223 ft

Radius	Fixed jib length in (ft)			
	36	46	66	85
(ft)	lbs	lbs	lbs	lbs
24,1	79,1			
30	79,1	78,4		
40	79,1	77,5	64,3	
45	79,1	76,9	63,4	45,2
80	65,0	66,0	55,5	40,4
120	34,7	35,3	36,7	33,4
160	20,4	20,9	22,0	22,9
235	7,0	7,4	8,2	9,0
245		6,2	7,0	7,8
265			4,9	5,6
285				3,7

Main boom 233 ft

Radius	Fixed jib length in (ft)			
	36	46	66	85
(ft)	lbs	lbs	lbs	lbs
24,4	79,1			
30	79,1	77,1		
40	79,1	76,2	62,0	
45	79,1	75,6	61,1	44,6
50	79,1	75,2	60,5	44,3
90	54,1	55,0	53,0	38,6
170	17,5	18,0	19,0	19,9
245	5,4	5,8	6,6	7,4
255		4,7	5,5	6,2
270			4,0	4,7
290				2,9

Main boom 243 ft

Radius	Fixed jib length in (ft)		
	36	46	56
(ft)	lbs	lbs	lbs
24,8	79,1		
30	79,1	75,9	
35	79,1	75,6	71,7
50	79,1	74,2	69,5
90	53,7	54,6	55,6
130	29,3	30,0	30,7
170	17,0	17,5	18,1
210	9,5	9,9	10,5
250	4,4	4,8	5,3
260		3,7	4,2
270			3,2

TLT 10576488 - M133451 Offiziell

Capacities in 1000 lbs with fixed jib (No. 1008.xx), 181,440 lbs counterweight + 79,400 lbs carbody counterweight. Above lift chart is for reference only. For actual lift duty and complete chart with all available configurations please refer to lift chart in operator's cab or manual.

Lift chart - fixed jib (No. 1008.xx)

Offset 30°

Main boom 66 ft

Radius	Fixed jib length in (ft)			
	36	46	66	85
(ft)	lbs	lbs	lbs	lbs
35	79,1			
40	74,5	62,0		
50	65,5	55,1	41,3	
60	58,4	49,9	36,4	29,2
70	53,0	45,8	32,8	26,6
80	49,8	41,9	29,9	24,9
90	47,1	38,7	27,4	22,6
100	44,9	36,5	26,4	20,9
110		35,1	24,9	19,3
130			23,2	17,1
150				16,0

Main boom 95 ft

Radius	Fixed jib length in (ft)			
	36	46	66	85
(ft)	lbs	lbs	lbs	lbs
35	79,1	64,6		
50	71,1	58,2	41,8	
60	64,0	52,8	37,9	29,5
75	56,3	48,3	33,3	26,5
95	50,4	41,7	28,8	23,2
105	48,1	39,2	26,9	21,7
115	42,8	37,3	26,4	20,3
125	37,7	36,1	25,2	19,1
135		34,2	24,3	18,2
155			23,3	16,7
175				16,1

Main boom 125 ft

Radius	Fixed jib length in (ft)			
	36	46	66	85
(ft)	lbs	lbs	lbs	lbs
29,4	79,1			
40	79,1	65,0		
50	74,2	62,2	43,2	
60	68,5	56,8	39,5	28,8
80	59,1	50,1	34,2	26,3
120	39,2	40,0	27,2	21,1
140	30,8	31,5	25,7	18,9
150	27,3	28,1	25,0	18,2
160		25,1	24,5	17,5
180			21,3	16,5
200				16,1

Main boom 154 ft

Radius	Fixed jib length in (ft)			
	36	46	66	85
(ft)	lbs	lbs	lbs	lbs
30,4	79,1			
40	79,1	63,7		
50	77,5	61,0	42,3	
65	69,3	55,3	38,0	28,8
80	62,5	50,9	34,5	26,6
100	50,3	46,6	30,9	24,4
140	29,8	30,6	26,6	20,1
175	19,8	20,5	21,7	17,6
185		18,2	19,4	17,1
205			15,5	16,5
225				13,2

Main boom 184 ft

Radius	Fixed jib length in (ft)			
	36	46	66	85
(ft)	lbs	lbs	lbs	lbs
31,4	79,1			
40	79,1	65,3		
50	78,3	63,2	41,8	
65	71,5	58,6	39,4	29,0
80	65,6	53,9	36,2	26,6
120	37,2	38,1	30,1	22,7
160	22,5	23,2	24,5	19,4
200	13,8	14,4	15,5	16,6
210		12,6	13,8	14,8
230			10,7	11,7
250				8,9

Main boom 203 ft

Radius	Fixed jib length in (ft)			
	36	46	66	85
(ft)	lbs	lbs	lbs	lbs
32,1	79,1			
40	79,1	65,1		
55	77,3	62,0	42,1	
65	72,4	59,4	39,6	28,8
100	48,6	49,7	33,4	25,2
140	28,0	28,8	28,5	21,3
180	16,9	17,5	18,8	18,6
220	9,9	10,4	11,5	12,5
230		8,9	10,0	11,0
250			7,4	8,3
270				6,0

Main boom 223 ft

Radius	Fixed jib length in (ft)			
	36	46	66	85
(ft)	lbs	lbs	lbs	lbs
32,8	79,1			
40	79,1	64,4		
55	76,7	62,0	42,0	
65	73,2	59,8	39,9	28,5
100	47,9	49,1	33,7	25,5
140	27,2	28,0	29,0	21,6
180	16,2	16,8	18,1	19,0
235	7,1	7,6	8,7	9,7
245		6,4	7,4	8,3
265			5,0	6,0
285				3,8

Main boom 233 ft

Radius	Fixed jib length in (ft)			
	36	46	66	85
(ft)	lbs	lbs	lbs	lbs
33,1	78,9			
40	78,9	62,3		
55	76,5	60,2	41,0	
65	73,5	58,0	39,2	28,4
140	26,8	27,7	28,8	21,8
180	15,8	16,4	17,8	19,0
220	8,8	9,3	10,4	11,5
245	5,5	6,0	7,0	8,0
255		4,8	5,8	6,8
275			3,6	4,6
295				2,6

Main boom 74 m

Radius	Fixed jib length in (ft)		
	36	46	56
(ft)	lbs	lbs	lbs
33,5	75,6		
40	75,5	60,7	
50	75,1	59,7	50,0
80	66,2	54,0	43,1
120	35,0	36,0	36,6
160	20,2	20,9	21,8
200	11,5	12,1	12,8
240	5,7	6,2	6,8
255	4,0	4,5	5,0
265		3,4	3,9
275			2,9

TLT 10576488 - M133451 Offiziell

Capacities in 1000 lbs with fixed jib (No. 1008.xx), 181,440 lbs counterweight + 79,400 lbs carbody counterweight. Above lift chart is for reference only. For actual lift duty and complete chart with all available configurations please refer to lift chart in operator's cab or manual.

Notice

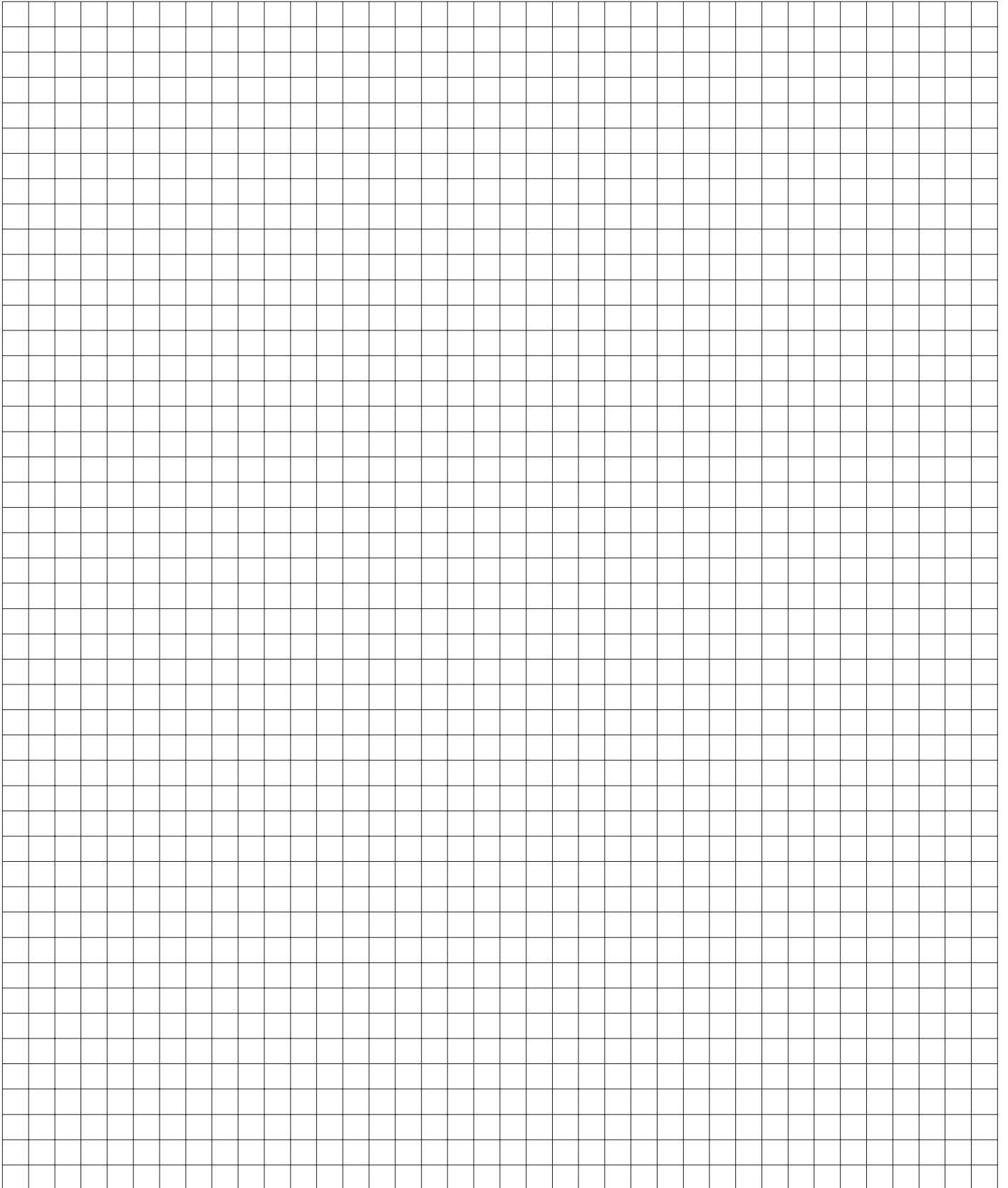

Liebherr Nenzing Crane Co.

7075 Bennington Street, Houston, TX 77028-5812

Tel.: (713) 636-4050, Fax: (713) 636-4051

crawler.crane@liebherr.com, www.liebherr.com

facebook.com/LiebherrConstruction