

DW 1.25 - 6.0

Twin-shaft mixer

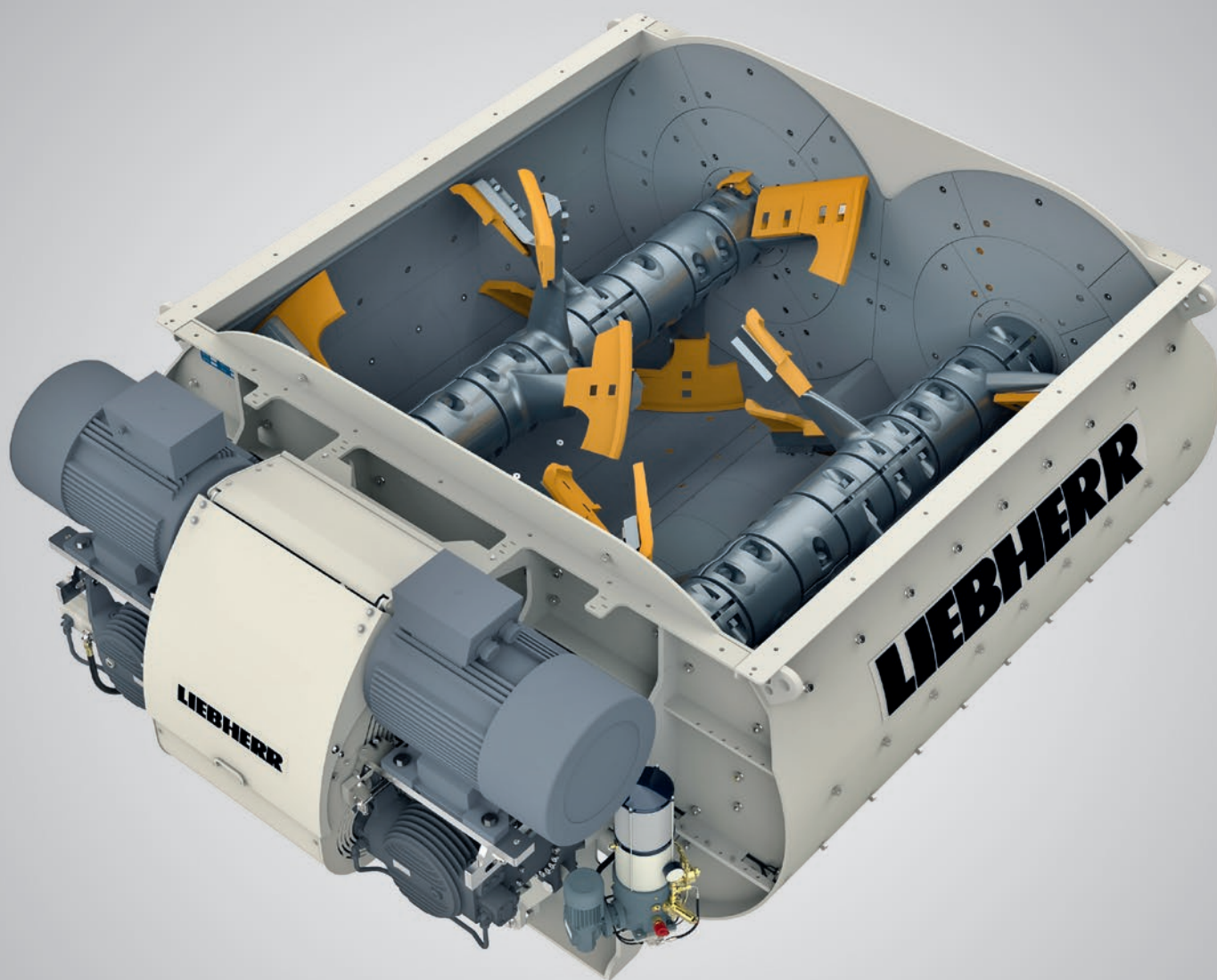

LIEBHERR

DW 1.25 - 6.0

Twin-shaft mixer

- Robust mixing tool with intertwining mixing arms in an arrangement of 60°
- Corrugated pattern of wear tiles made of chrome-nitrite chilled casting
- Wear-resistant labyrinth sealing in sectioned design
- High-performance drive motors
- Efficient powertrain with Liebherr planetary gearbox
- External hydraulic double pump
- Clearly arranged service positions on the drive side
- Central grease unit with special grease (CTK)
- Hydraulic mixer gate

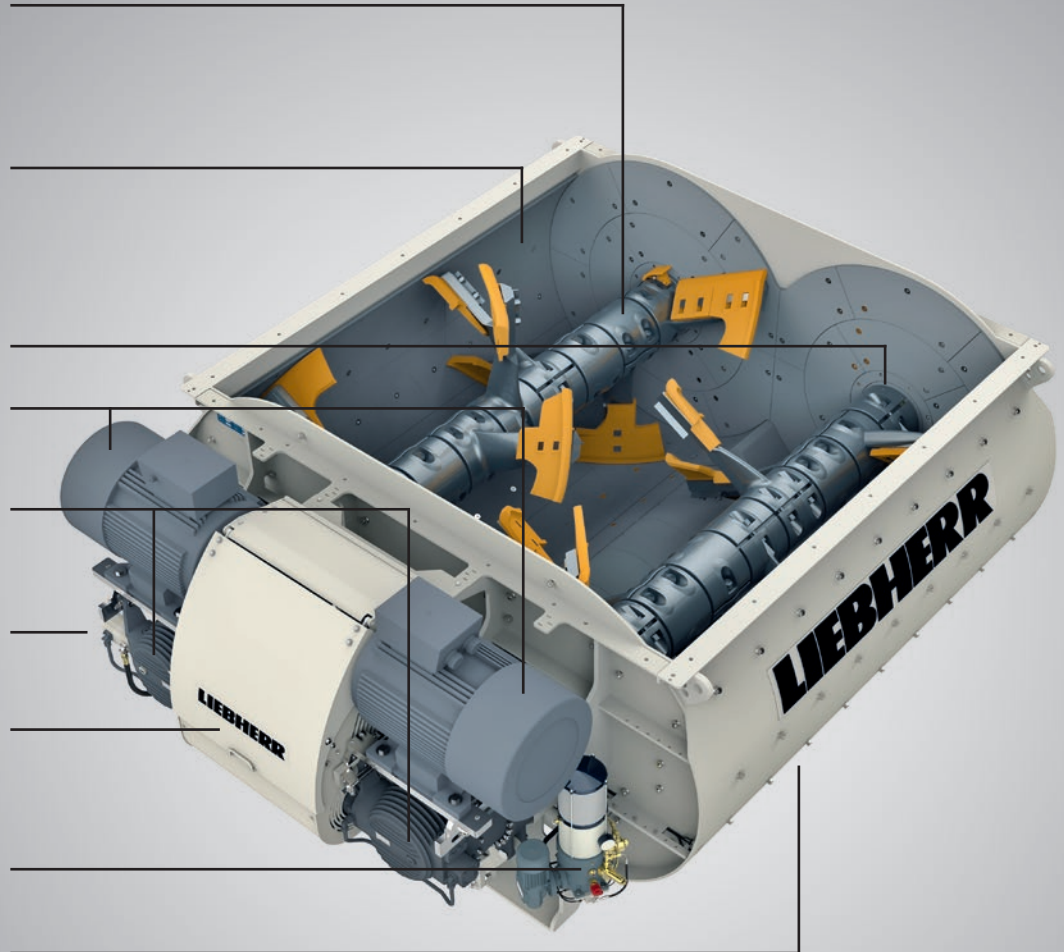

The twin-shaft mixers made for ready-mix concrete with enhanced customer benefit

The new Liebherr twin-shaft mixers are setting a new benchmark regarding the economical production of ready-mix concrete. Many years of experience and special details ensure a maximum customer benefit by well-known Liebherr-quality. Liebherr twin-shaft mixers are honored by high mixing quality, short mixing times and good accessibility.

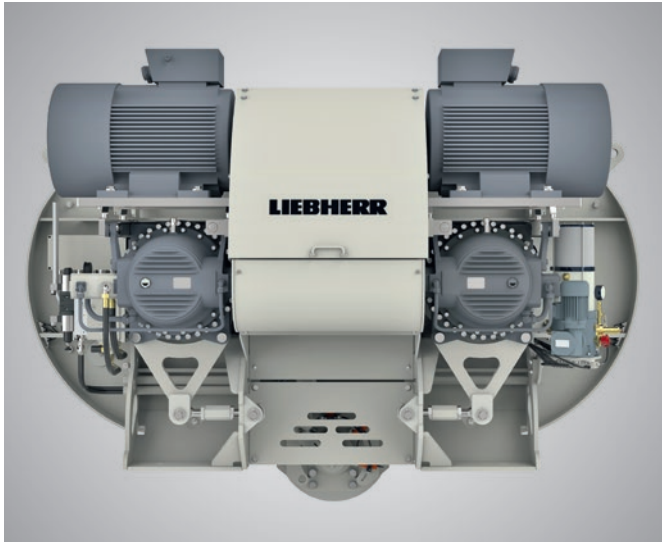

Efficient powertrain

The efficient Liebherr planetary gear boxes are favouring an optimum energy input into the mixing material. Excellent mixing results can be realized in a short period. Independent hydraulic circuits ensure maximum operational safety and a long lifetime. One for the mechanics and one for the lubrication and for the cooling of the gearbox. Maintenance activities can be conducted quickly due to the clearly arranged service positions on the drive side. This results in a high availability of the mixer.

Improved wear properties

- The wear-resistant labyrinth sealing is protecting the bearings, which results in a longer lifetime. The sectioned design simplifies the disassembly of the sealing considerably in case of replacement.
- The usage of a central grease unit as standard with Liebherr special grease (CTK) results in a long lifetime of the seals and the bearings. The high-viscosity and water-repellent properties of the CTK grease is assuring the operation of the plant also among extreme conditions.

Robust mixing tool with wear tiles

- The mixer is designed for highest loads because of the robust mixing tool and the corrugated pattern of the wear tiles which are made of chromium carbide. The corrugated pattern prevents the gaps between the wear plates from washing out (wear) in an early stage.
- The arrangement of the mixing arms results in high shearing forces during the mixing process. Cement and admixtures are dissolved in an optimal way.

Hydraulic mixer gate

The hydraulic mechanism for closing the mixer gate utilizes high performance and control whilst maintaining maximum efficiency. There are no disruptions in the operation procedures because of clamped aggregates. The mixer gate is always closing properly and prevents soiling by outrunning concrete.

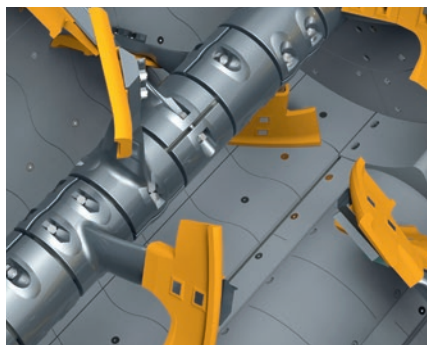

DW 1.25 - 6.0

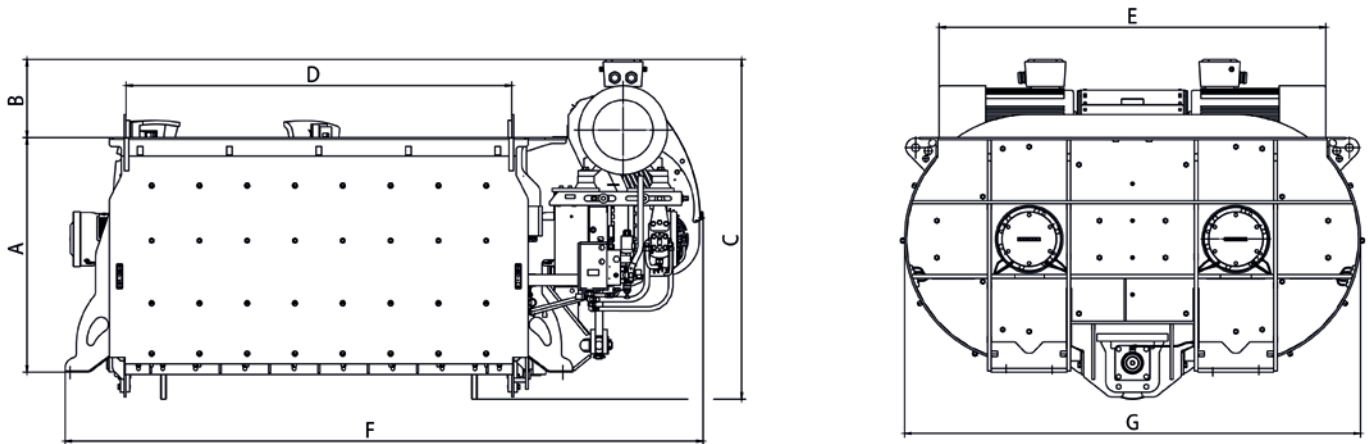

Options

- High-pressure cleaning system
- Variable design of the mixer cover
- Mixing tool for coarse grit
- Others on request

Technical data

		1.25	2.5	3.0	3.5	4.5	6.0	
Nominal capacity according to DIN 459, part 1	m ³	1,25	2,5	3,0	3,5	4,5	6,0	
Filling capacity	l	1875	3750	4500	5250	6750	9000	
Dimensions of the standard model	A	mm	1200	1300	1300	1500	1800	
	B _{min}	mm	460	460	460	460	460	
	C	mm	1650	2000	2000	2000	2100	2400
	D	mm	1350	1850	2100	2650	2400	2800
	E	mm	1700	2050	2110	2050	2400	2700
	F	mm	2700	3200	3460	3975	3735	4387
	G	mm	2100	2400	2500	2400	2900	3200
Three-phase motor for the mixing tool	kW	45	75	2 x 55	2 x 55	2 x 75	2 x 110	
Voltage / frequency	V/Hz	400/50	400/50	400/50	400/50	400/50	400/50	
Rotation speed of the mixing tool	rpm	27	20	20	20	20	21	
Outer peripheral speed	m/s	1,57	1,35	1,35	1,35	1,56	1,87	
Weight of the standard model	t	5,0	7,3	8,5	10,2	13,2	15,5	