Pumping concrete perfectly

Compact and versatile

LIEBHERR

36 XXT truck mounted concrete pump



36 XXT – The all-rounder.



Five-part multi-fold distributor boom

XXT-outrigger

XXT-outrigger

The proven XXT-outrigger is particularly flexible when supporting in tight spaces.

Powerbloc inside

The Powerbloc hydraulic drive, developed and manufactured by Liebherr, combines power and smooth running, made by Liebherr.

Five-part multi-fold distributor boom

Short arms and large swivel angles of the joints provide impressive mobility at confined construction sites.



Powerbloc inside

Variable storage spaces

Compact design

Highest safety and ergonomics

Variable storage spaces

A wealth of storage options to best suit customer requirements.

Compact design

Compact assembly with no overhang ensures manoeuvrability and transparency.

Highest safety and ergonomics

All control stations are ergonomic and meet the highest safety standards.

Flexible at the construction site Manoeuvrable on the road



One boom for all situations!

The five-part multi-fold distributor boom (RRRZZ) is very suitable for confined construction sites and working inside buildings due to its low unfolding height, above-average mobility and excellent slip properties.

Highlights

Vehicle length

The option of mounting the 36 XXT on a three-axle chassis makes the truck mounted concrete pump particularly light and compact. The boom terminating with the feed hopper shortens the machine enormously, which noticeably increases manoeuvrability at the construction site and in road traffic.

Boom concept

The design of the boom sustainably ensures quiet and vibration-free operation, even at high outputs.

Flexibility

The five arms and the good slip properties allow maximum flexibility at the construction site. A wide variety of positions can thus be reached perfectly at the construction site.

Robustness

The robust design of the machine ensures reliable operation for many years at low operating costs. Numerous design details facilitate tough everyday use.



Unfolding height

With an unfolding height of the boom of only 7.2 meters, concreting in confined spaces or halls is no obstacle for the machine.

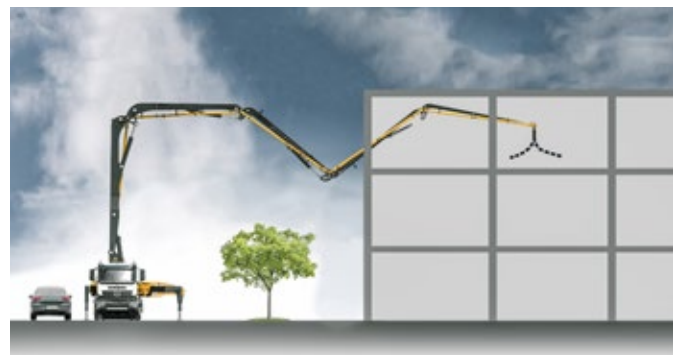

Slip properties

Good slip properties facilitate concreting in existing buildings on different floors.

XXT-outrigger **No space? – No problem!**



Space-saving safety when supporting

The proven XXT-outrigger is particularly flexible when supporting in tight spaces.

XXT-outrigger

Perfect in every situation

With the XXT-outrigger, the boom loads are transferred along the shortest path to the contact areas of the support legs. No forces act on the vehicle frame. The support legs all swivel around the same axis of rotation. The narrow support functions offer numerous variable set-up options.

Narrow support

The XXT-outrigger offers great advantages compared to other supports: The front outrigger on the confined side can still be extended and supported up to the front of the driver's cab thanks to the swivel option, thus adding the entire working area in front of the driver's cab (see figures below). Even if both sides are narrowly supported, it is still possible to work over the driver's cab.

XXA stability control system

The XXA stability control system guarantees safe working in any situation. Depending on the position of the support and boom, only non-critical movements are allowed. The safe working area is indicated on the radio remote control in the colour display.

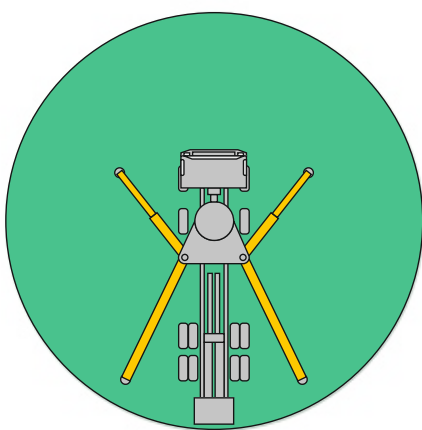

Full support

The innovative XXT-support gives the truck mounted concrete pump maximum stability in all areas. Supporting is quick, even on uneven terrain.

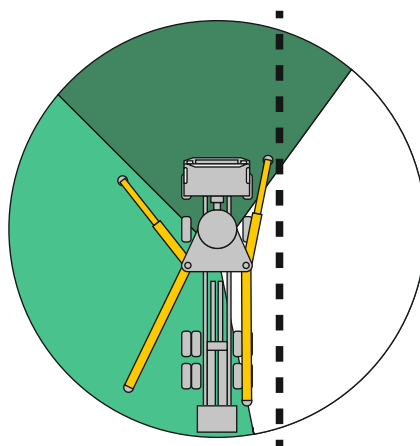

Narrow support

When one side is XXT-supported due to space constraints, the outrigger shows its full strength. The support at the right front (swivelling) enables the additional working area (dark green) in front of the vehicle.

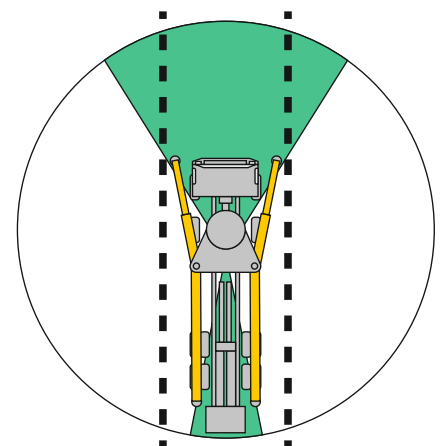

Narrow support on both sides

In the extreme case of narrow support on both sides, the truck mounted concrete pump can still work where others have to capitulate, thanks to the XXT-support.

Powerbloc and HCC

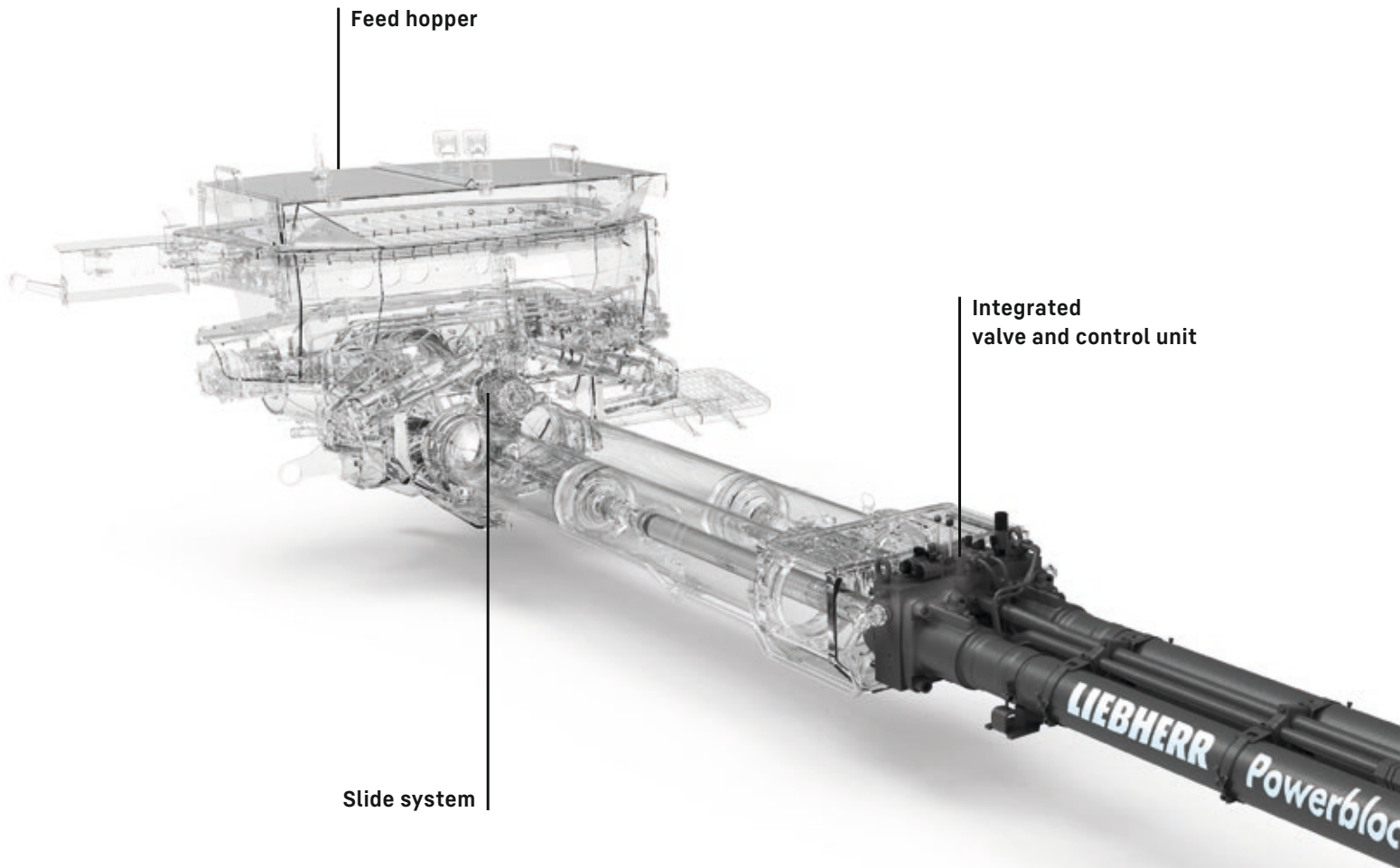

Powerbloc

The Powerbloc is characterized by high performance and smooth running. The latest generation of the Powerbloc does not require a separate control block, as all hydraulic switching and measuring elements are integrated. Only four hoses are required.

Feed hopper

The optimized hopper shape promotes concrete flow and reduces concrete deposits. The separate agitator paddles and the wide suction openings guarantee optimum suction performance. The feed hopper enables easy cleaning due to good accessibility.

Slide system

Powerful slide system with smooth change of direction thanks to end position damping. The controller controls the oil quantity perfectly matched to the switchover cycles. S-pipe switchover is performed via two hydraulic cylinders with full pressure from the main hydraulic pump. The conveying cylinders are hard-chrome plated for long service lives.

Powerbloc



Powerbloc QR code

HCC

Semi-closed oil circuit

The innovative Powerbloc drive unit is complemented by a newly designed, highly efficient semi-closed oil circuit. This guarantees that all drives are permanently supplied with reliable and powerful hydraulic power.

The new Liebherr own system combines the advantages of the proven open and closed hydraulic systems currently on the market, without their disadvantages. The system operates without a storage pump and without a reservoir. The required oil volume is significantly reduced, which saves costs and weight.

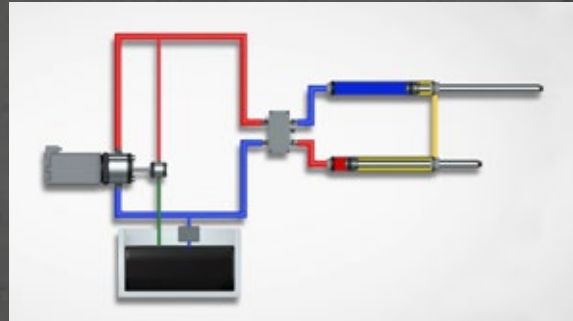

HCC QR code

Equipment and accessories

Lighting

Numerous LED headlights on the entire vehicle ensure optimum light during construction site operations. This ensures comfortable and safe working. We will be glad to advise you about our countless other equipment options.



Secure with safety

Safety is our top priority

We are committed to the applicable safety rules. In the development of Liebherr truck mounted concrete pumps, safety for people and the machine is the top priority. We observe our machines in use and continuously improve them.

Our truck mounted concrete pumps have:

- Large treads and platforms
- Height-adjustable steps on the left (ergonomics)
- Good accessibility and ergonomic arrangement of the control stations
- Full railings and fall protection devices
- A broad lighting concept in LED for work in poor light conditions or work at construction sites at night
- Illumination of the control stations
- Radio control with flashlight function and control panel illumination as well as vibration alarm and emergency stop function in case of a fall (dead man's switch)

Always on the safe side with XXA

The XXA stability control system monitors the permitted working area and guarantees safe working in any situation. Depending on the position of the support and boom, only non-critical movements are allowed.

Safe working in any situation:

- Digital inclination monitoring
- Traffic light on the boom for additional visualization of the machine status at the construction site

Note: The XXA stability monitoring with inclination monitoring is standard on delivery to the EU.



Spacious treads and platforms

Spacious steps for safe access to all control points on the machine and for cleaning the feed hopper.



Signal light

Signal light on the concrete boom for visual status display of the XXA stability control system at the construction site.



Remote control

The radio remote control informs the operator about all important machine parameters.

36 XXT technical data



Standard version. Dimensions and total weight may change depending on pump type and chassis.

Technical data

Boom	36 M5
Vertical range	35.8 m
Horizontal range	31.5 m
Unfolding height	7.2 m
Swivel range	365°
Angle range of arm 1	96°
Angle range of arm 2	180°
Angle range of arm 3	180°
Angle range of arm 4	240°
Angle range of arm 5	240°
Conveyor line diameter	125 mm
End hose length	4 m
Voltage	24 V

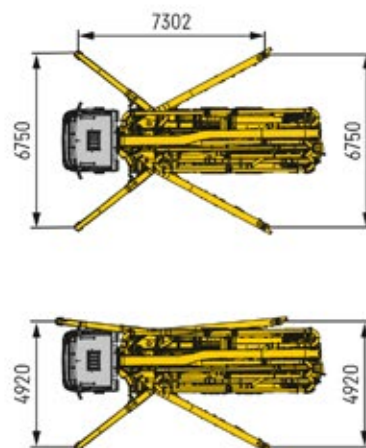

Concrete pump	THP 140 Powerbloc	THP 170 Powerbloc
Max. flow rate (piston side)	144 m ³ /h	167 m ³ /h
Max. concrete pressure (piston side)	80 bar	80 bar
Pump cycles (piston side)	29 min ⁻¹	34 min ⁻¹
Conveyor cylinder Ø x stroke	230 mm x 2000 mm	230 mm x 2000 mm
Concrete conveying volume / double stroke	166 L	166 L
Max. hydraulic pressure	350 bar	350 bar
Drive cylinder	110 mm / 80 mm / 2000 mm	110 mm / 80 mm / 2000 mm
Hopper capacity	600 L	600 L
Noise emission (L _{WA})	119 dB	119 dB

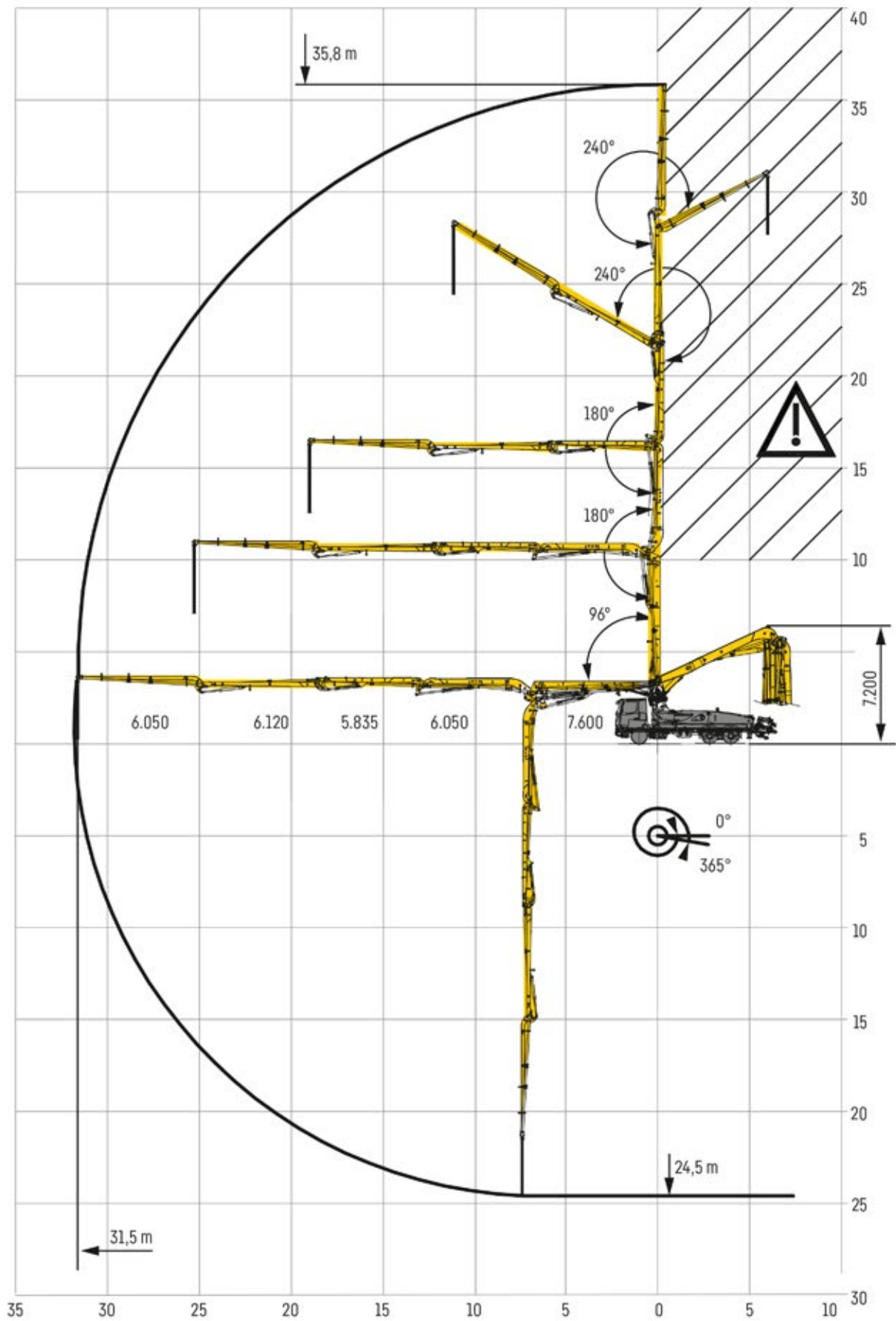

Customer service



Service out of conviction

Good service means close customer proximity. With our professional service network, we are at your disposal with rapid response times to ensure high machine availability. Reliable machines are the guarantee for your success. Our highly trained service personnel make sure your Liebherr truck mounted concrete pumps operate economically and seamlessly.

We help with start-up machine operator instruction and by answering your questions.



Liebherr service partners worldwide

Our customers can rely on a worldwide service network consisting of over 90 service centres (Liebherr companies / partners), 160 service vehicles and 220 qualified service technicians. Our worldwide service centres with all contacts can be found on the Liebherr website or in the MyLiebherr customer portal.



Service-friendly design

During construction, great importance was attached to ease of service. Wearing parts are easy to replace, important areas are easily accessible.



Our customer portal – MyLiebherr

MyLiebherr is your entry into the Liebherr service world. Through the Liebherr customer portal, our customers benefit from comprehensive service and additional benefits.



Original Liebherr spare parts

Original Liebherr spare parts are subject to strict quality controls, are quickly available worldwide and guarantee reliable operation and a long service life.

We are here for you!

Personal. Capable. Reliable.



Concrete pumps



Mixing plants



Truck mixer



Conveyor belts



Measuring technology



Mixing systems



Concrete recycling system

Your powerful partner.

- Delivery and instruction by experienced service technicians
- Worldwide service network with over 90 service centres
- Technical support worldwide
- Fast availability of spare parts
- Professional maintenance and services

Liebherr-Mischtechnik GmbH · Postbox 145 · 88423 Bad Schussenried, Germany
+49 7583 949-0 · www.liebherr.com · info.lmt@liebherr.com

**Get your
contact**

