Pumping concrete perfectly

Classic and practical

LIEBHERR

38 XXT truck mounted concrete pump



38 XXT – The classic



Four-part boom

Highest safety and ergonomics

XXT-outrigger

Variable storage spaces

Powerbloc inside

XXT-outrigger

The pivoting XXT support is particularly versatile when supporting in tight spaces.

Powerbloc inside

The Powerbloc concrete pump drive, developed and manufactured by Liebherr, combines power and smooth running, made by Liebherr.

Four-part boom

The 38 XXT is easy to handle thanks to the practical Z-folding and stands out in the 30-metre class with its very large reach height.



Robustness

Variable storage spaces

A wealth of storage options enable the best possible adaptation to customer requirements.

Highest safety and ergonomics

All control stations are ergonomic and meet the highest safety standards.

Robustness

The robust design of the machine ensures reliable operation for many years at low operating costs.

Classic and practical!





Highlights

Boom concept

With its classic four-part boom and practical Z-folding, the 38 XXT is easy to handle and stands out in the 30-metre class with its very large reach height. The even division of the arms make the 38 XXT a versatile classic. Due to the above-average swivel range of the joints, concrete can be pumped effortlessly even on construction sites that are difficult to access.

Flexible choice of vehicle

Depending on the customer's wishes, the 38 XXT can be mounted on either a three- or four-axle chassis.

Robustness

The robust design of the machine ensures reliable operation for many years at low operating costs. Numerous well thought-out details facilitate tough everyday use.



No space? – No problem!



Space-saving safety when supporting

The proven XXT-outrigger is particularly flexible when supporting in tight spaces.

XXT-outrigger

Perfect in every situation

The XXT support transfers the boom loads along the shortest path to the contact areas of the support legs. No forces act on the vehicle frame. On each side of the vehicle, the front and rear support legs swivel around the same axis to save space.

Narrow support

The XXT-outrigger offers great advantages compared to other supports: Nonetheless, even on the side where there is little space, the front support can still be extended in front of the driver's cab thanks to the swivel option. This adds the entire working area in front of the driver's cab. Even with narrow support on both sides, work is possible across the driver's cab.

Partial support

The versatile XXT support is unbeatable when supporting in tight spaces. The big advantage: In particularly cramped situations with little space, it is possible to work in the side area despite partial support with boom arm 1 raised. Pumping can always be carried out across the cab with the boom fully extended.

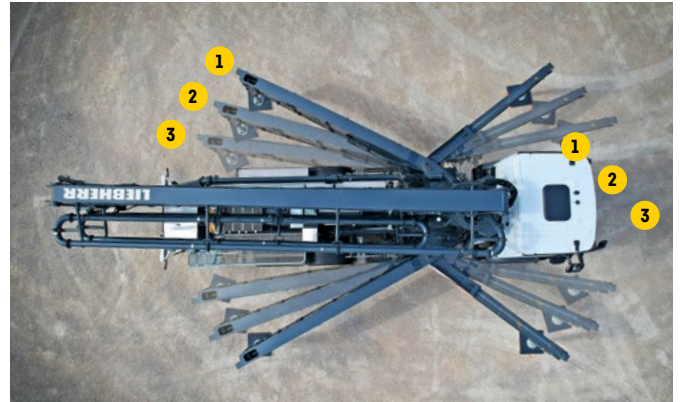

1. Full support
2. Partial support
3. Narrow support

XXA stability control system

Thanks to the new XXA stand safety control, partial support areas are made possible and electronically monitored. Thus, the new stability offers even more application possibilities due to the multitude of additional support options and at the same time ensures safe working in every situation. The approved slewing range of the boom is indicated on the radio remote control in the colour display.

- Full support, boom can be fully extended
- Partial support, boom arm 1 raised

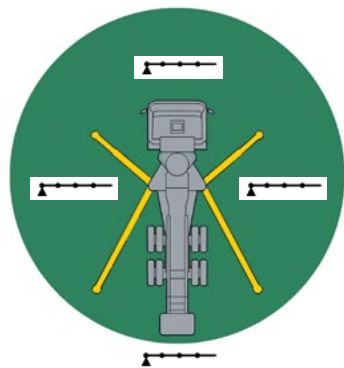

Full support

The innovative XXT support gives the truck mounted concrete pump maximum stability at all times. Supporting is quick, even on uneven terrain.

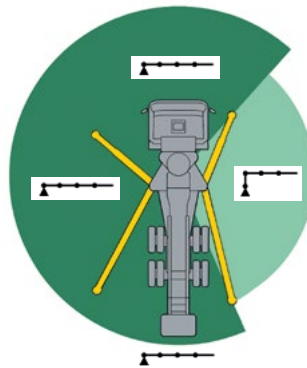

Single-side partial support

In the partially supported area, work can also be carried out on this side with boom arm 1 raised.

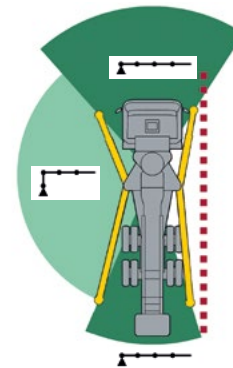

Combination of partial and narrow support

The combination of partial and narrow support on one side enables a large variable slewing range for the boom with minimum space requirement.

Powerbloc and HCC

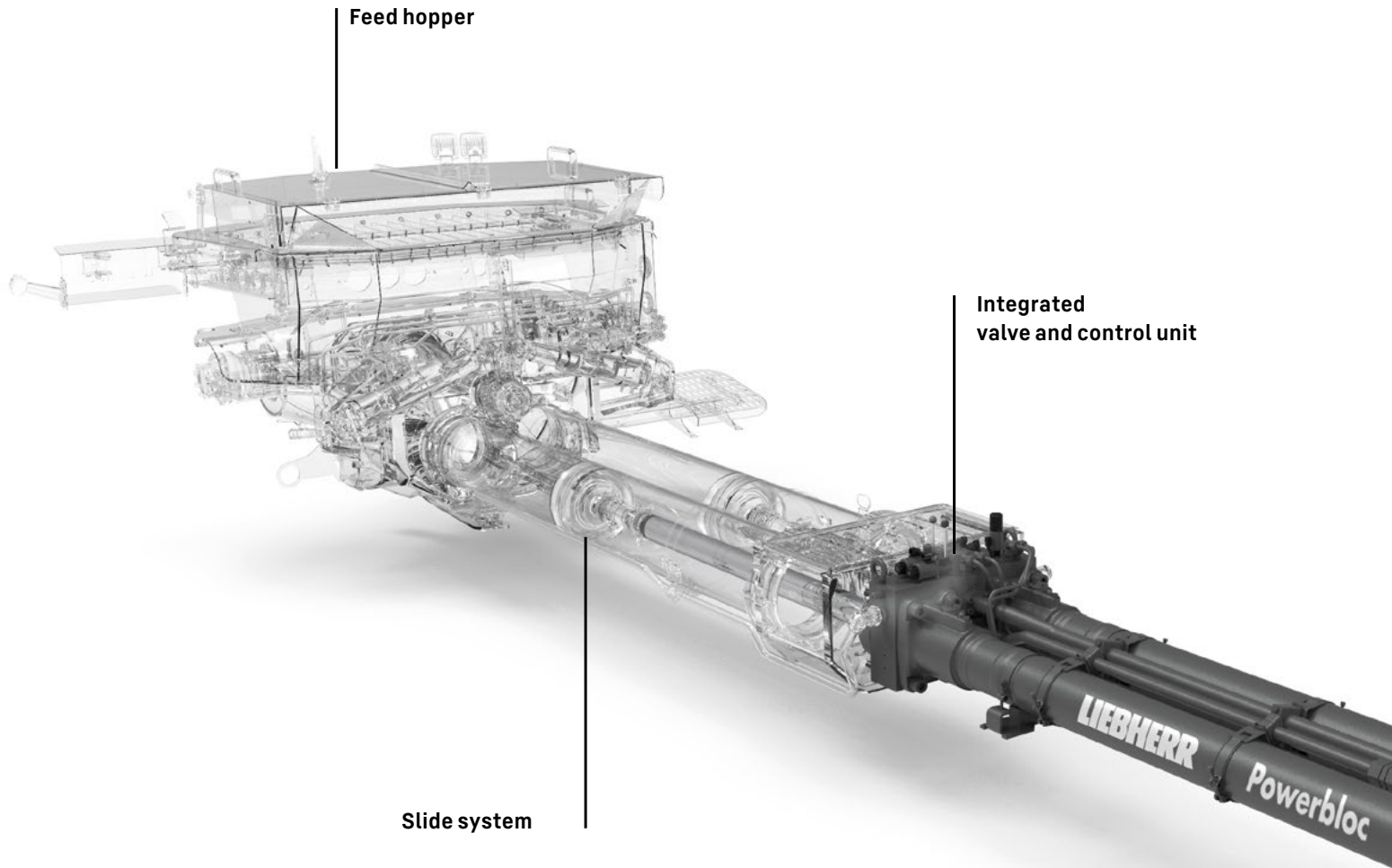

Powerbloc

The Powerbloc is characterized by high performance and smooth running. The latest drive unit for concrete pumps does not require a separate control block, as all hydraulic switching and measuring elements are integrated.

Feed hopper

The optimized hopper shape promotes concrete flow and reduces concrete deposits. The separate agitator paddles and the wide suction openings guarantee optimum suction performance. The feed hopper enables easy cleaning due to good accessibility.

Slide system

Powerful slide system with smooth change of direction thanks to controlled pipe changeover. The controller controls the oil quantity perfectly wmatched to the switchover cycles. The S-pipe changeover is implemented via two hydraulic cylinders with full pressure from the main hydraulic pump.

Powerbloc

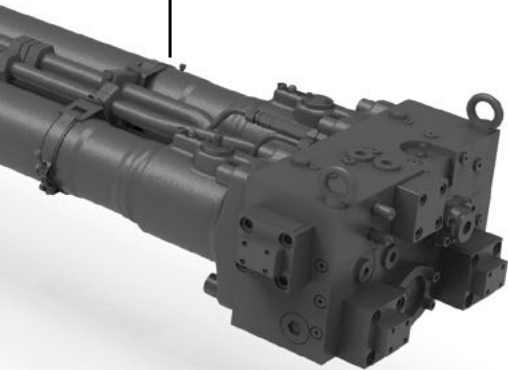

Powerbloc QR code

HCC

Semi-closed oil circuit

The innovative Powerbloc drive unit is complemented by a newly designed, highly efficient semi-closed oil circuit. This guarantees that all drives are permanently supplied with reliable and powerful hydraulic power.

The new Liebherr own system combines the advantages of the proven open and closed hydraulic systems currently on the market, without their disadvantages. The system operates without a storage pump and without a reservoir. The required oil volume is significantly reduced, which saves costs and weight.

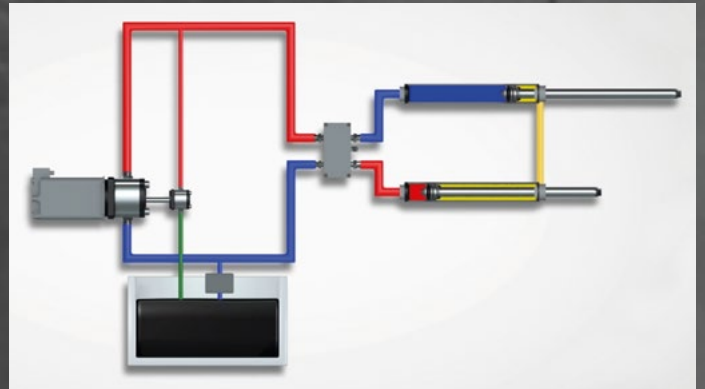

HCC QR code

Equipment and accessories



Safe and pleasant working

The comprehensive guardrails and fall protection devices ensure maximum safety. The generous steps allow easy access to all control stations on the machine.

Secure with safety

Safety is our top priority

We are committed to the applicable safety rules. In the development of Liebherr truck mounted concrete pumps, safety for people and the machine is the top priority. We observe our machines in use and continuously improve them.

Our truck mounted concrete pumps have:

- Large treads and platforms
- Height-adjustable steps on the left (ergonomics)
- Good accessibility and ergonomic arrangement of the control stations
- Full railings and fall protection devices
- A broad LED lighting concept for work in poor lighting conditions or work at construction sites at night
- Illumination of the control stations
- Radio remote control with flashlight function and control panel illumination as well as vibration alarm and emergency stop function in case of a fall (dead man's switch)

Always on the safe side with XXA

The XXA stability control monitors the approved slewing range of the boom as well as the correct positioning of the machine.

Digital inclination monitoring

The safety of man and machine is ensured thanks to the digital inclination monitoring. When setting up the machine, the machine tilt is monitored. The two-stage inclination monitoring even allows excessive tilting of up to 5° under restricted operating conditions and alerts the machine operator and the surrounding area of the construction site via radio display and signal light.

Save working in any situation:

- Digital inclination monitoring
- Traffic light on the boom for additional visualization of the machine status at the construction site

Note: The XXA stability monitoring with inclination monitoring is standard on delivery to the EU.



Spacious treads and platforms

Spacious steps for safe access to all control points on the machine and for cleaning the feed hopper.



Signal light

Signal light on the concrete boom for visual status display of the XXA stability control system at the construction site.



Remote control

The radio remote control informs the operator about all important machine data.

Technical data 38 XXT

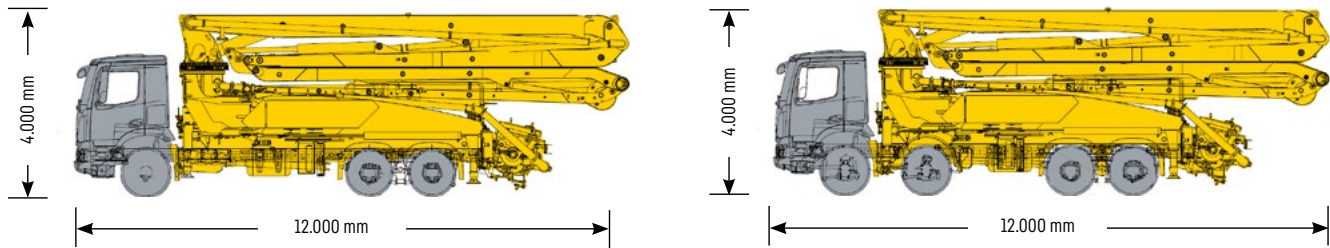

Standard version. Dimensions and total weight may change depending on pump type and chassis.

Technical data

Boom	38 Z4
Vertical range	37.1 m
Horizontal range	32.8 m
Unfolding height	8.75 m
Swivel range	365°
Angle range of arm 1	96°
Angle range of arm 2	180°
Angle range of arm 3	240°
Angle range of arm 4	240°
Conveyor line diameter	125 mm
End hose length	4 m
Voltage	24 V

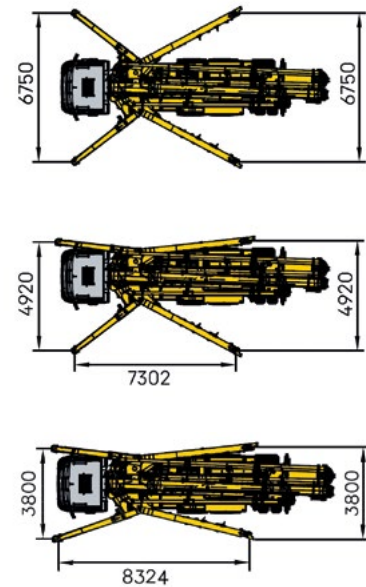

Concrete pump	THP 140 Powerbloc	THP 170 Powerbloc
Max. flow rate (piston side)	144 m ³ /h	167 m ³ /h
Max. concrete pressure (piston side)	80 bar	80 bar
Pump cycles (piston side)	29 min ⁻¹	34 min ⁻¹
Conveyor cylinder Ø x stroke	230 mm x 2000 mm	230 mm x 2000 mm
Concrete conveying volume / double stroke	166 L	166 L
Max. hydraulic pressure	350 bar	350 bar
Drive cylinder	110 mm / 80 mm / 2000 mm	110 mm / 80 mm / 2000 mm
Hopper capacity	600 L	600 L
Noise emission (L _{WA})	119 dB	119 dB

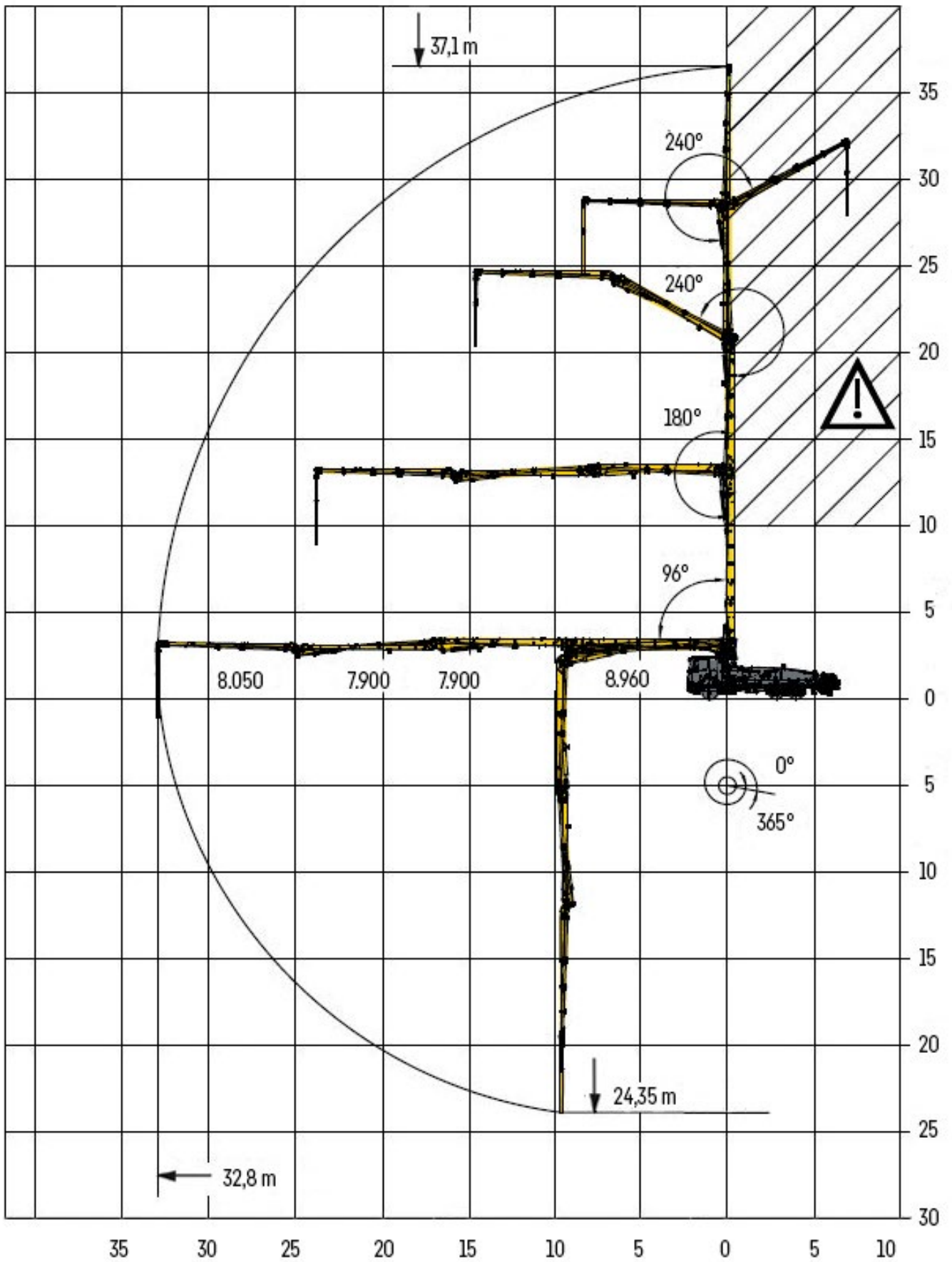

Customer service



Service out of conviction

Good service means close customer proximity

With our professional service network, we are at your disposal with rapid response times to ensure high machine availability. Reliable machines are the guarantee for your success. Our highly trained service personnel make sure your Liebherr truck mounted concrete pumps operate economically and seamlessly. We help with start-up machine operator instruction and by answering your questions.

Liebherr service partners worldwide

Our customers can rely on a worldwide service network consisting of over 90 service centres (Liebherr companies/partners), 160 service vehicles and 220 qualified service technicians. Our worldwide service centres with all contacts can be found on the Liebherr website or in the MyLiebherr customer portal.



Service-friendly design

During construction, great importance was attached to ease of service. Wearing parts are easy to replace, important areas are easily accessible.



Our customer portal – MyLiebherr

MyLiebherr is your entry into the Liebherr service world. Through the Liebherr customer portal, our customers benefit from comprehensive service and additional benefits.



Original Liebherr spare parts

Original Liebherr spare parts are subject to strict quality controls, are quickly available worldwide and guarantee reliable operation and a long service life.

We are here for you!

Personal. Capable. Reliable.



Concrete pumps



Mixing plants



Truck mixers



Conveyor belts



Measuring technology



Mixing systems



Concrete recycling systems

Your powerful partner.

- Delivery and instruction by experienced service technicians
- Worldwide service network with over 90 service centres
- Technical support worldwide
- Fast availability of spare parts
- Professional maintenance and services

Liebherr-Mischtechnik GmbH • Postbox 145 • 88423 Bad Schussenried, Germany
+49 7583 949-0 • www.liebherr.com • E-Mail: info.lmt@liebherr.com

Get your
contact

