

# Product Information Log Loader

## LH 35 M Timber

Litronic®

### Generation

6

### Operating Weight

61,700 – 66,600 lb\*

### Engine

201 HP (l)/150 kW

Stage Tier 4f

\* Without attachment



# LIEBHERR



## Performance

Power Plus Speed –  
Redefined Performance

## Economy

Good Investment –  
Savings for Long-Term





## Reliability

Durability and Sustainability –  
Quality Down to the Last Detail

## Comfort

Perfection at a Glance –  
When Technology is Comfortable

## Maintainability

Efficiency Bonus –  
Even with Maintenance and Service





# Well Thought Out to the Last Detail





#### **Optimised Travel Motor**

- Better performance with lower fuel consumption even on uphill grades
- Powerful, robust, reliable and quiet



#### **Rigid Cab Elevation LFC 120**

- New, clever, space-saving access system with integrated treads and 10° inclination for easy access and more safety



#### **Height-Adjustable Trailer Coupling at 2-point / Blade Support**

- The height of the coupling jaw can be set and adjusted in increments of 2.4" in a range between approx. 29.9" and 3'6"
- Simple and fast adjustment of coupling jaw height to the drawbar height



# Convincing in Operation



## Performance

### Increased Engine Output

Engine output has been increased from 140 kW to 150 kW compared to the predecessor models, giving the system more torque for more powerful movement. Furthermore, load peaks are compensated cleverly, meaning maximum torque is available at all times for maximum handling capacity.

### Captivating Dynamics

The combination of 150 kW of engine output and an increased pump delivery volume guarantees maximum acceleration and speed of working motions.

### 4-Wheel Steering

The standard 4-wheel steering provides great agility and manoeuvrability of the log loader, even in the tight space of a timber yard. Furthermore, the 4-wheel steering increases driving stability and improves the driving in one lane.

### Optimised Undercarriage Concept for Trailer Operation

The combination of a log loader and trailer is the optimal choice for longer distances. Thanks to the new undercarriage concept with 2-point/blade support, the material handling capacity is increased significantly in trailer operation. The 2-point outrigger guarantees maximum stability and high lift capacities during loading and unloading of the trailer across the entire slewing range. As a result, more logs can be handled per work cycle and productivity is increased. The blade can also be used for clearing and thus increases safety in the timber yard.



## Economy

### **Closed Hydraulic Circuit for the Swing Mechanism**

The closed slewing circuit feeds the braking energy back into the system when the uppercarriage is braked. Here, new standards are set in terms of efficiency and economy. Simple yet effective.

### **Liebherr-Power Efficiency (LPE)**

LPE optimizes the interaction of the drive components in terms of efficiency and enables machine operation in the area of the lowest specific fuel use for less consumption and greater efficiency with the same performance.

### **Efficient Drive Operation**

The electric swivel angle adjustment in the drive motor provides for more torque, maximum acceleration and higher traction. That allows a constantly high performance to be called up even on uphill grades. Optimal adjustment of speed and delivery volume ensures impressive fuel efficiency even at maximum speed.

# Convincing in Operation



## Reliability

### Quality and Competence

Our experience, understanding of customer needs and the technical implementation of these findings guarantee the success of the product. For decades, Liebherr has been inspirational with its knowledge of production and system solutions. Key components such as the diesel engine, electronic components, slewing ring, swivelling drive and hydraulic cylinders are developed and produced by Liebherr itself. The great depth of in-house manufacturing guarantees maximum quality and ensures that components are optimally configured to each other.

### Protective Devices

Especially in tough timber application the material handlers are used heavily. The optional protective devices extend the component service life and guarantee high machine availability with maximum safety for people and machine.

### Intelligent Self Diagnostics

The clever control electronics permanently monitor the vital functions of the machine to guarantee a high level of machine availability. Components which are critical for safety are designed with redundancy to guarantee maximum safety.

## Comfort

### Proportional Control

In timber yards, where space is tight, precision and fine control are especially important. The 4-way mini-joystick with its proportional control make for efficient use of the machine. The streamlined design and ergonomic form of the joystick further increase functionality directly in the hands of the operator for simple and efficient control.





## Maintainability

### **Slewing Gear Brake Comfort**

The standard slewing gear brake comfort control allows the selection between the mode manual, semiautomatic and automatic.

This standard slewing gear brake in the manual mode can be opened and closed with the button on the joystick.

In the semiautomatic mode the slewing gear brake can also be closed manually but automatically opened again when the uppercarriage is moved via the joystick control.

The automatic mode allows the slewing gear brake to be closed automatically when the predefined time, set by the operator, has passed and the uppercarriage has stopped moving. It will open automatically as soon as the uppercarriage is moved via the joystick control.

By opening and closing the slewing gear brake automatically the operator can work faster and more safely with less effort.

### **Service-Based Machine Design**

The service-based machine design guarantees short servicing times, thus minimizing maintenance costs due to the time it saves. All the maintenance points are easily accessible from the ground and easy to reach due to the large, wide-opening service doors. The enhanced service concept places the maintenance points close to each other and reduces their number to a minimum. This means that service work can be completed even more quickly and efficiently.

### **Integral Maintenance Benefits**

Completing maintenance work helps keep the machine fully functional. Maintenance work does, however, mean machine down times which must be minimized. Automatic central lubrication systems for attachment and the uppercarriage as well as optional systems for the undercarriage, quick coupling system and working tools not only make it easier to observe the recommended lubrication intervals and ensure a long service life for the components, but also increase the productivity of the Liebherr log loader LH 35 M Timber.



# Technical Data



## Diesel Engine

<b>Rating per SAE J1349/ISO 9249</b>	201 HP (l) (150 kW) at 1,700 rpm
<b>Model</b>	Liebherr D934
<b>Type</b>	4 cylinder in-line
<b>Bore/Stroke</b>	4.8/5.9 in
<b>Displacement</b>	427,17 in <sup>3</sup>
<b>Engine operation</b>	4-stroke diesel Common-Rail turbo-charged and after-cooled reduced emissions
<b>Air cleaner</b>	dry-type air cleaner with pre-cleaner, primary and safety elements
<b>Engine idling</b>	sensor controlled
<b>Electrical system</b>	
<b>Voltage</b>	24 V
<b>Batteries</b>	2 x 135 Ah/ 12 V
<b>Alternator</b>	three-phase current 28 V/ 140 A
<b>Stage Tier 4f</b>	
<b>Harmful emissions values</b>	in accordance with EPA/CARB-40CFR stage Tier 4f
<b>Emission control</b>	Liebherr-SCR technology
<b>Fuel tank</b>	87 gal
<b>Urea tank</b>	12 gal



## Cooling System

<b>Diesel engine</b>	water-cooled compact cooling system consisting cooling unit for water, hydraulic oil and charge air with stepless thermostatically controlled fan
----------------------	--



## Hydraulic Controls

<b>Power distribution</b>	via control valves with integrated safety valves, simultaneous actuation of chassis and equipment. Swing drive in separate closed circuit
<b>Servo circuit</b>	
<b>Equipment and swing</b>	with hydraulic pilot control and proportional joystick levers
<b>Chassis</b>	electro-proportional via foot pedal
<b>Additional functions</b>	via switch or electro-proportional foot pedals
<b>Proportional control</b>	proportionally acting transmitters on the joysticks for additional hydraulic functions



## Hydraulic System

<b>Hydraulic pump</b>	for equipment and travel drive	2 Liebherr axial piston variable displacement pumps (double construction)
<b>Max. flow</b>		2 x 61 gpm
<b>Max. pressure</b>		5,076 psi
<b>for swing drive</b>		reversible axial piston variable displacement pump, closed-loop circuit
<b>Max. flow</b>		37 gpm
<b>Max. pressure</b>		6,092 psi
<b>Hydraulic pump regulation and control</b>		Liebherr-Synchron-Comfort-system (LSC) with electronic engine speed sensing regulation, pressure and flow compensation
<b>Hydraulic tank</b>		46 gal
<b>Hydraulic system</b>		114 gal
<b>Hydraulic oil filter</b>		1 main return filter with integrated partial micro filtration (5 µm)
<b>MODE selection</b>		adjustment of engine and hydraulic performance via a mode pre-selector to match application, e.g. for especially economical and environmentally friendly operation or for maximum material handling and heavy-duty jobs
<b>S (Sensitive)</b>		mode for precision work and lifting through very sensitive movements
<b>E (Eco)</b>		mode for especially economical and environmentally friendly operation
<b>P (Power)</b>		mode for high performance with low fuel consumption
<b>P+ (Power-Plus)</b>		mode for highest performance and for very heavy duty applications, suitable for continuous operation
<b>Engine speed and performance setting</b>		stepless alignment of engine output and hydraulic power via engine speed
<b>Option</b>		Tool Control: 20 pre-adjustable pump flows and pressures for add-on attachments



## Swing Drive

<b>Drive</b>	Liebherr axial piston motor in a closed system, Liebherr planetary reduction gear
<b>Swing ring</b>	Liebherr, sealed race ball bearing swing ring, internal teeth
<b>Swing speed</b>	0 – 9,5 rpm stepless
<b>Swing torque</b>	56,055 lbf ft
<b>Holding brake</b>	wet multi-disc (spring applied, pressure released)
<b>Operation holding brake</b>	slewing gear brake Comfort





## Operator's Cab

<b>Cab</b>	TOPS safety cab structure (tip-over protection) with individual windscreens or featuring a slide-in subpart under the ceiling, work headlights integrated in the ceiling, a door with a sliding window (can be opened on both sides), large stowing and depositing possibilities, shock-absorbing suspension, sound damping insulating, tinted laminated safety glass, separate shades for the sunroof window and windscreen
<b>Operator's seat Comfort</b>	air cushioned operator's seat with 3D-adjustable armrests, headrest, lap belt, seat heater, adjustable seat cushion inclination and length, lockable horizontal suspension, automatic weight adjustment, adjustable suspension stiffness, pneumatic lumbar vertebrae support and passive seat climatization with active coal
<b>Operator's seat Premium (Option)</b>	in addition to operator's seat comfort: active electronic weight adjustment (automatic re-adjustment), pneumatic low frequency suspension and active seat climatization with active coal and ventilator
<b>Control system</b>	joysticks with control consoles and swivel seat, folding left control console
<b>Operation and displays</b>	large high-resolution operating unit, self-explanatory, color display with touchscreen, video-compatible, numerous settings, control and monitoring options, e.g. air conditioning control, fuel consumption, machine and attachment parameters
<b>Air-conditioning</b>	automatic air-conditioning, recirculated air function, fast de-icing and demisting at the press of a button, air vents can be operated via a menu; recirculated air and fresh air filters can be easily replaced and are accessible from the outside; heating-cooling unit, designed for extreme outside temperatures, sensors for solar radiation, inside and outside temperatures



## Undercarriage

<b>Drive</b>	oversized two speed power shift transmission with additional creeper speed, Liebherr axial piston motor with functional brake valve on both sides
<b>Travel speed</b>	Joystick and wheel steering 0 – 2.2 mph stepless (creeper speed + transmission stage 1) 0 – 4.3 mph stepless (transmission stage 1) 0 – 8.1 mph stepless (creeper speed + transmission stage 2) 0 – 12.4 mph stepless (transmission stage 2)
<b>Driving operation</b>	automotive driving using accelerator pedal, cruise control function: storage of variable accelerator pedal positions
<b>Axes</b>	132,277 lb drive axles; manual or automatic hydraulically controlled front axle oscillation lock
<b>Four wheel steering</b>	standard
<b>Steering reversal control</b>	standard
<b>Service brake</b>	two circuit travel brake system with accumulator; wet and backlash-free disc brake
<b>Holding brake</b>	wet multi-disc (spring applied, pressure released)
<b>Stabilization</b>	stabilizer blade rear
Option	stabilizer blade rear and front stabilizer blade rear + 2 point outriggers front



## Equipment

<b>Type</b>	high-strength steel plates at highly-stressed points for the toughest requirements. Complex and stable mountings of equipment and cylinders
<b>Hydraulic cylinders</b>	Liebherr cylinders with special seal system as well as shock absorption
<b>Bearings</b>	sealed, low maintenance



## Complete Machine

<b>Lubrication</b>	Liebherr central lubrication system for upper-carriage and equipment, automatically
Option	Liebherr central lubrication system for under-carriage, automatically
<b>Steps system</b>	safe and durable access system with anti-slip steps; main components hot-galvanized
<b>Noise emission</b>	
ISO 6396	$L_{pA}$ (inside cab) = 71 dB(A)
2000/14/EC	$L_{WA}$ (surround noise) = 103 dB(A)



# Dimensions

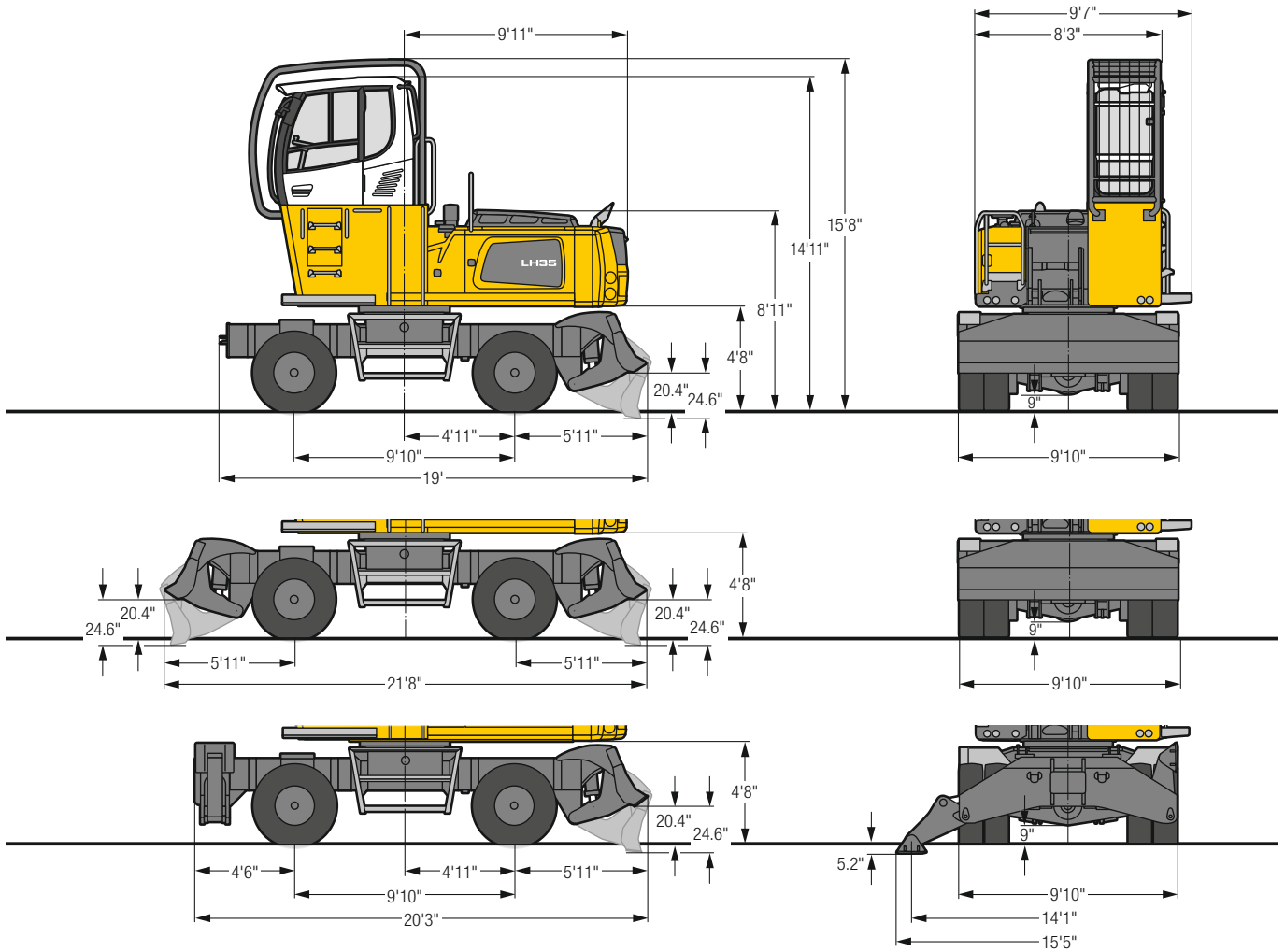

# Turning Radiuses

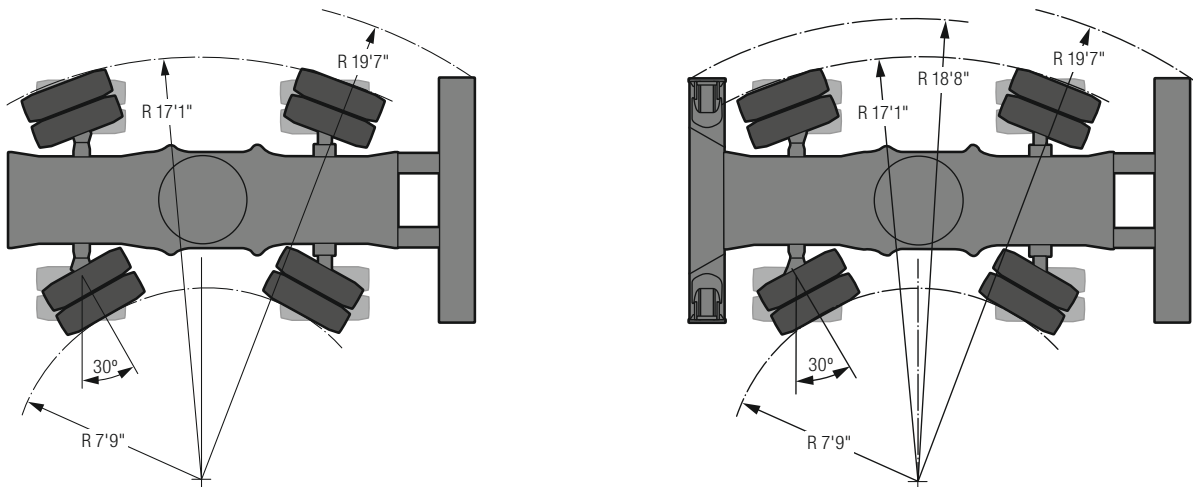

Tires 12.00-20



# Dimensions

## EW-Undercarriage

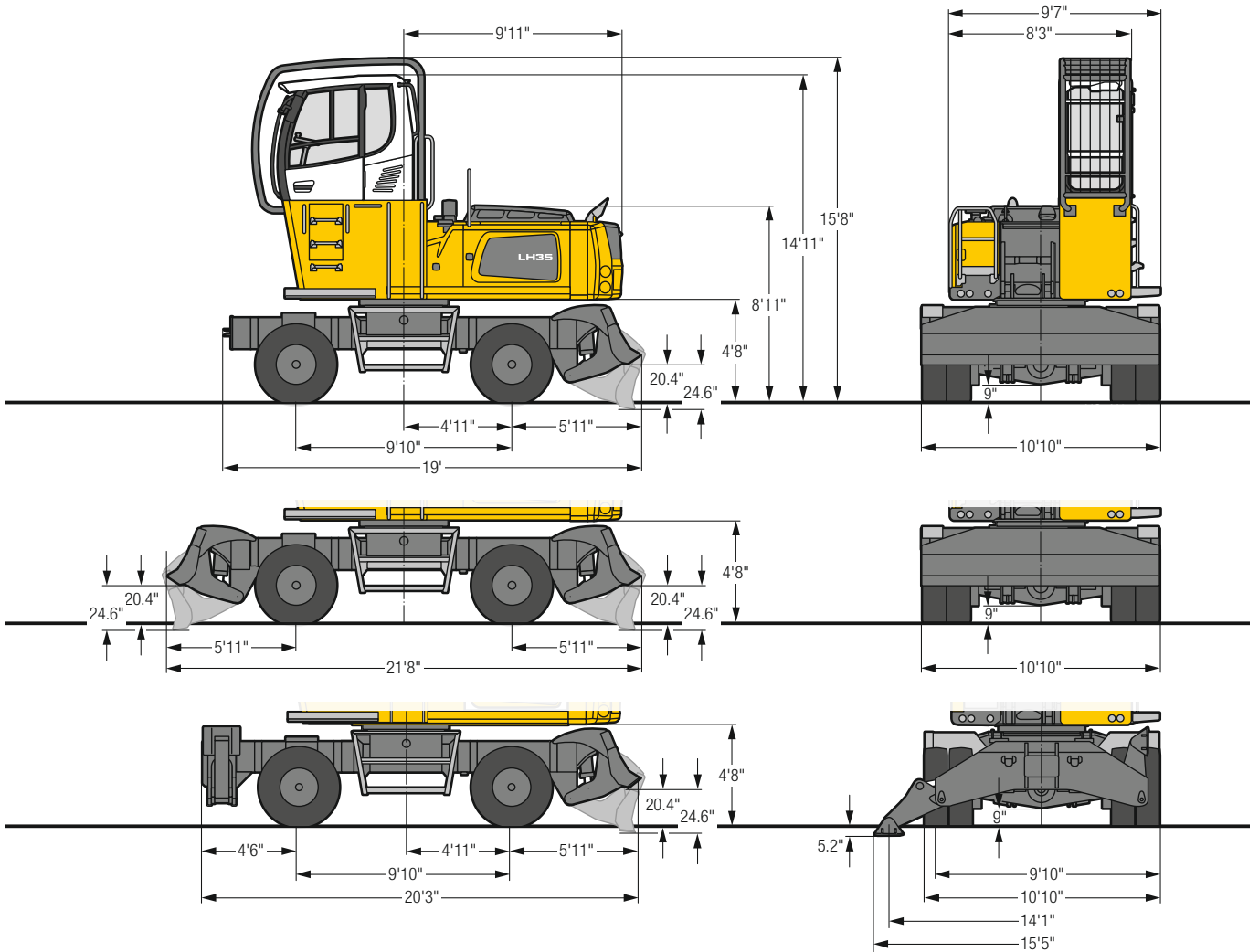

# Turning Radiuses

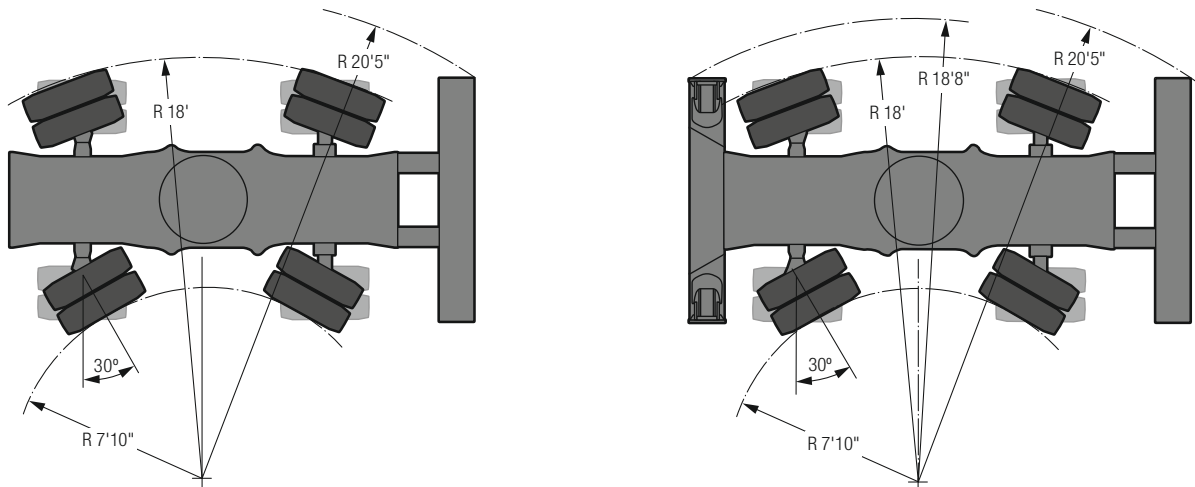

Tires 12.00-20

# Equipment GA10

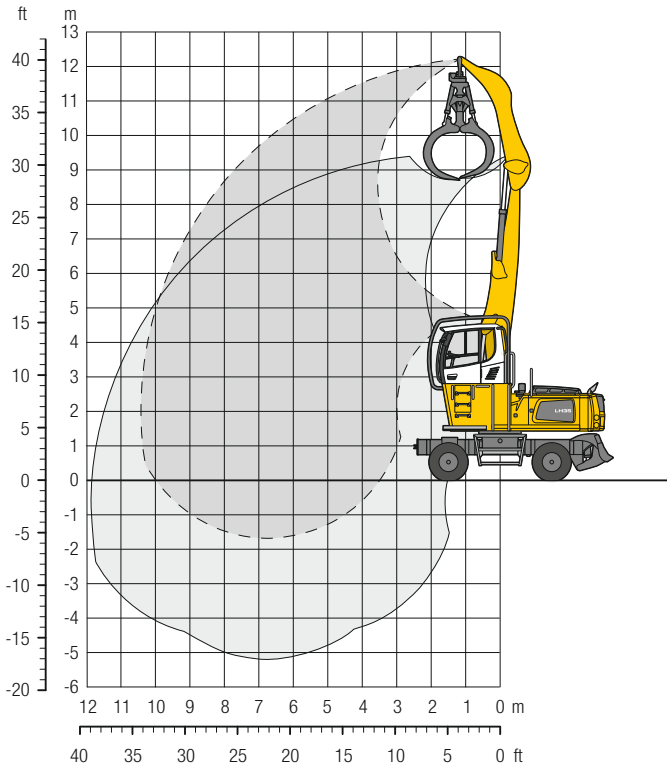

## Operating Weight

The operating weight includes the basic machine with stabilizer blade, rigid cab elevation, 8 pneumatic tires, straight boom 21'4", angled stick 13'1" and wood grab GM 20B/ 2.03 yd<sup>2</sup>.

Weight 65,300 lb

## Dimensions

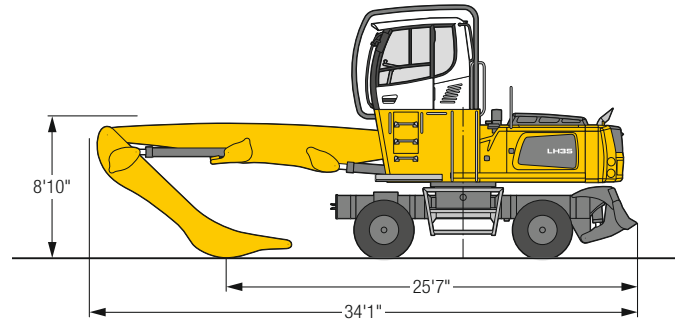

ft	Undercarriage	10 ft		15 ft		20 ft		25 ft		30 ft		35 ft		ft in		
40	Stabilizers raised (drive operation)													29,3"	29,3"	4' 8"
	Stabilizers raised													29,3"	29,3"	
	Stabilizer blade down													29,3"	29,3"	
35	Stabilizers raised (drive operation)	25,3"	25,3"	19,0	21,3"									13,2	15,6"	18' 8"
	Stabilizers raised	25,3"	25,3"	21,3"	21,3"									15,6"	15,6"	
	Stabilizer blade down	25,3"	25,3"	21,3"	21,3"									15,6"	15,6"	
30	Stabilizers raised (drive operation)			19,4	22,3"	12,3	16,3							8,6	11,4	24'10"
	Stabilizers raised			22,3"	22,3"	15,4	18,2"							10,7	13,3"	
	Stabilizer blade down			22,3"	22,3"	16,3	18,2"							11,4	13,3"	
25	Stabilizers raised (drive operation)			19,3	22,3"	12,3	16,2	8,6	11,4					6,8	9,0	28'10"
	Stabilizers raised			22,3"	22,3"	15,4	18,1"	10,8	14,2					8,5	11,2	
	Stabilizer blade down			22,3"	22,3"	16,3	18,1"	11,5	15,2"					9,0	12,3"	
20	Stabilizers raised (drive operation)	27,0"	27,0"	18,6	23,5"	12,0	15,9	8,5	11,2	6,3	8,4			5,8	7,8	31' 6"
	Stabilizers raised	27,0"	27,0"	23,3	23,5"	15,0	18,5"	10,6	14,0	7,9	10,5			7,3	9,7	
	Stabilizer blade down	27,0"	27,0"	23,5"	23,5"	15,9	18,5"	11,3	15,3"	8,4	12,7"			7,8	11,9"	
15	Stabilizers raised (drive operation)	33,3	37,7"	17,5	23,9	11,4	15,3	8,2	10,9	6,2	8,3			5,3	7,1	33' 2"
	Stabilizers raised	37,7"	37,7"	21,8	25,3"	14,3	19,1	10,3	13,7	7,8	10,4			6,6	8,9	
	Stabilizer blade down	37,7"	37,7"	23,3	25,3"	15,2	19,2"	10,9	15,4"	8,3	12,6"			7,1	10,7"	
10	Stabilizers raised (drive operation)	7,8"	7,8"	16,0	22,3	10,7	14,5	7,9	10,6	6,0	8,1			5,0	6,8	34'
	Stabilizers raised	7,8"	7,8"	20,0	26,8"	13,4	18,2	9,8	13,2	7,6	10,2			6,3	8,5	
	Stabilizer blade down	7,8"	7,8"	21,4	26,8"	14,3	19,7"	10,5	15,4"	8,1	12,2"			6,7	9,5"	
5	Stabilizers raised (drive operation)	2,9"	2,9"	14,8	20,9	10,1	13,9	7,5	10,2	5,9	8,0			4,9	6,7	34' 1"
	Stabilizers raised	2,9"	2,9"	18,5	25,8"	12,6	17,4	9,4	12,8	7,3	9,9			6,2	8,3"	
	Stabilizer blade down	2,9"	2,9"	19,9	25,8"	13,5	19,1"	10,1	14,7"	7,9	11,4"			6,6	8,3"	
0	Stabilizers raised (drive operation)			14,2	20,3	9,7	13,5	7,3	10,0	5,8	7,8			5,1	7,0	32'10"
	Stabilizers raised			17,8	21,8"	12,2	16,8	9,1	12,5	7,2	9,7"			6,4	7,5"	
	Stabilizer blade down			19,2	21,8"	13,1	17,0"	9,8	13,1"	7,7	9,7"			6,9	7,5"	
-5	Stabilizers raised (drive operation)					9,6	13,2"	7,2	9,9					6,9	9,5	25'10"
	Stabilizers raised					12,0	13,2"	9,0	10,2"					8,7	9,8"	
	Stabilizer blade down					12,9	13,2"	9,6	10,2"					9,3	9,8"	

Height Can be slewed through 360° In longitudinal position of undercarriage Max. reach \* Limited by hydr. capacity

The lift capacities on the stick end without attachment are stated in lb x 1,000 and are valid on a firm, level supporting surface with blocked oscillating axle. These capacities can be slewed through 360° with the undercarriage in the transverse position. Capacities in the longitudinal position of the undercarriage (+/- 15°) are specified over the steering axle with the stabilizers raised and over the rigid axle with the stabilizers down. Indicated loads based on the ISO 10567 standard and do not exceed 75% (according to EN 474-5 in drive operation only 60%) of tipping or 87% of hydraulic capacity. The lift capacity of the unit is limited by its stability, the lifting capability of the hydraulic elements, or the maximum permissible lifting capacity of the load hook.



# Equipment GA10

## EW-Undercarriage

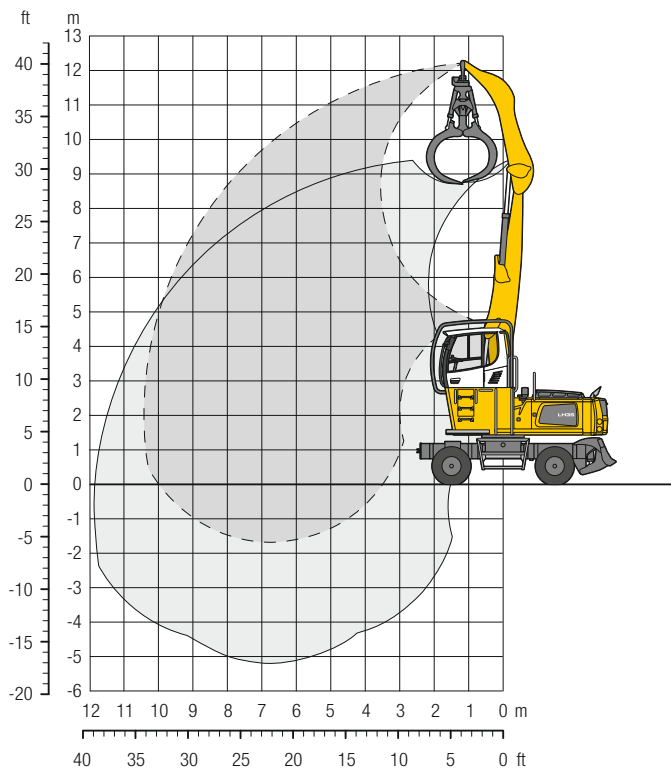

### Operating Weight

The operating weight includes the basic machine with stabilizer blade, rigid cab elevation, 8 pneumatic tires, straight boom 21'4", angled stick 13'1" and wood grab GM 20B/2.03 yd<sup>2</sup>.

Weight 65,900 lb

### Dimensions

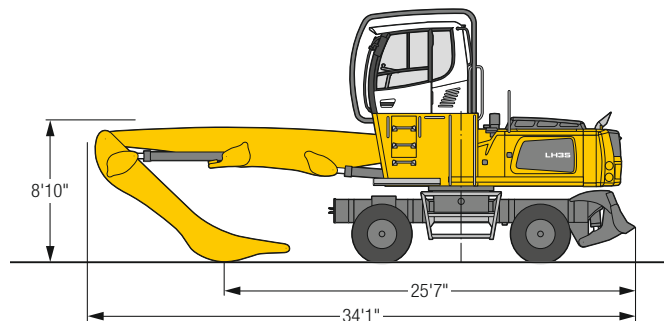

ft	Undercarriage	10 ft		15 ft		20 ft		25 ft		30 ft		35 ft		ft in		
40	Stabilizers raised (drive operation)													29,3"	29,3"	4' 8"
	Stabilizers raised													29,3"	29,3"	
	Stabilizer blade down													29,3"	29,3"	
35	Stabilizers raised (drive operation)	25,3"	25,3"	21,3"	21,3"									15,1"	15,6"	18' 8"
	Stabilizers raised	25,3"	25,3"	21,3"	21,3"									15,6"	15,6"	
	Stabilizer blade down	25,3"	25,3"	21,3"	21,3"									15,6"	15,6"	
30	Stabilizers raised (drive operation)			22,3"	22,3"	14,1"	16,6"							9,8"	11,6"	24'10"
	Stabilizers raised			22,3"	22,3"	17,6"	18,2"							12,3"	13,3"	
	Stabilizer blade down			22,3"	22,3"	18,2"	18,2"							13,1"	13,3"	
25	Stabilizers raised (drive operation)			22,2"	22,3"	14,1"	16,6"	9,9"	11,6"					7,8"	9,2"	28'10"
	Stabilizers raised			22,3"	22,3"	17,6"	18,1"	12,3"	14,6"					9,7"	11,5"	
	Stabilizer blade down			22,3"	22,3"	18,1"	18,1"	13,1"	15,2"					10,3"	12,3"	
20	Stabilizers raised (drive operation)	27,0"	27,0"	21,5"	23,5"	13,7"	16,2"	9,7"	11,5"	7,3"	8,6"			6,7"	8,0"	31' 6"
	Stabilizers raised	27,0"	27,0"	23,5"	23,5"	17,1"	18,5"	12,2"	14,4"	9,1"	10,8"			8,4"	10,0"	
	Stabilizer blade down	27,0"	27,0"	23,5"	23,5"	18,2"	18,5"	12,9"	15,3"	9,7"	12,7"			8,9"	11,9"	
15	Stabilizers raised (drive operation)	37,7"	37,7"	20,3"	24,4"	13,1"	15,6"	9,4"	11,2"	7,2"	8,5"			6,1"	7,3"	33' 2"
	Stabilizers raised	37,7"	37,7"	25,3"	25,3"	16,4"	19,2"	11,8"	14,0"	8,9"	10,6"			7,6"	9,1"	
	Stabilizer blade down	37,7"	37,7"	25,3"	25,3"	17,5"	19,2"	12,5"	15,4"	9,5"	12,6"			8,1"	10,7"	
10	Stabilizers raised (drive operation)	7,8"	7,8"	18,7"	22,8"	12,4"	14,9"	9,1"	10,8"	7,0"	8,3"			5,8"	6,9"	34'
	Stabilizers raised	7,8"	7,8"	23,4"	26,8"	15,5"	18,6"	11,3"	13,5"	8,7"	10,4"			7,3"	8,7"	
	Stabilizer blade down	7,8"	7,8"	25,1"	26,8"	16,6"	19,7"	12,1"	15,4"	9,3"	12,2"			7,7"	9,5"	
5	Stabilizers raised (drive operation)	2,9"	2,9"	17,5"	21,5"	11,8"	14,2"	8,7"	10,5"	6,8"	8,2"			5,7"	6,8"	34' 1"
	Stabilizers raised	2,9"	2,9"	21,8"	25,8"	14,7"	17,8"	10,9"	13,1"	8,5"	10,2"			7,1"	8,3"	
	Stabilizer blade down	2,9"	2,9"	23,5"	25,8"	15,8"	19,1"	11,7"	14,7"	9,1"	11,4"			7,6"	8,3"	
0	Stabilizers raised (drive operation)			16,9"	20,8"	11,4"	13,8"	8,5"	10,2"	6,7"	8,0"			6,0"	7,2"	32'10"
	Stabilizers raised			21,1"	21,8"	14,2"	17,0"	10,6"	12,8"	8,4"	9,7"			7,5"	7,5"	
	Stabilizer blade down			21,8"	21,8"	15,3"	17,0"	11,4"	13,1"	8,9"	9,7"			7,5"	7,5"	
-5	Stabilizers raised (drive operation)					11,2"	13,2"	8,4"	10,1"					8,1"	9,7"	25'10"
	Stabilizers raised					13,2"	13,2"	10,2"	10,2"					9,8"	9,8"	
	Stabilizer blade down					13,2"	13,2"	10,2"	10,2"					9,8"	9,8"	

Height Can be slewed through 360° In longitudinal position of undercarriage Max. reach \* Limited by hydr. capacity

The lift capacities on the stick end without attachment are stated in lb x 1,000 and are valid on a firm, level supporting surface with blocked oscillating axle. These capacities can be slewed through 360° with the undercarriage in the transverse position. Capacities in the longitudinal position of the undercarriage (+/- 15°) are specified over the steering axle with the stabilizers raised and over the rigid axle with the stabilizers down. Indicated loads based on the ISO 10567 standard and do not exceed 75% (according to EN 474-5 in drive operation only 60%) of tipping or 87% of hydraulic capacity. The lift capacity of the unit is limited by its stability, the lifting capability of the hydraulic elements, or the maximum permissible lifting capacity of the load hook.

# Equipment GA11

## EW-Undercarriage

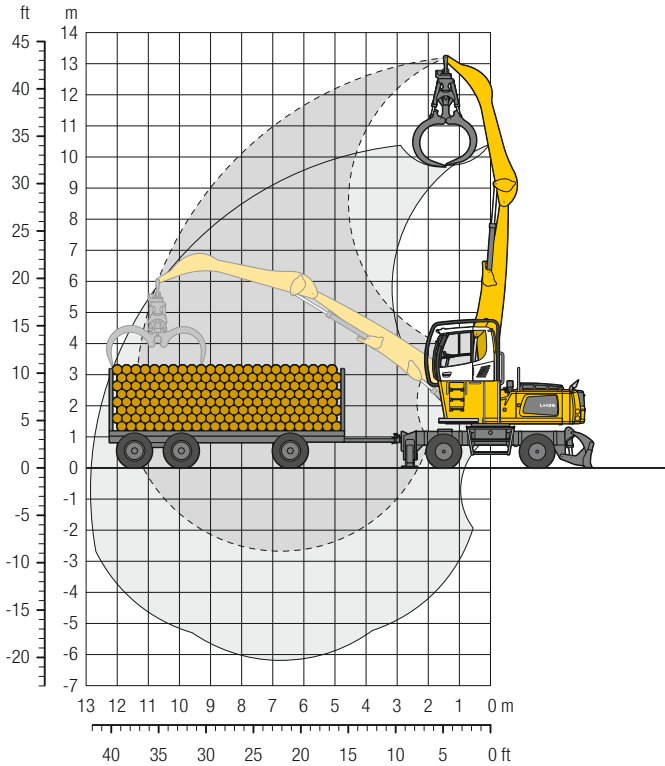

### Operating Weight

The operating weight includes the basic machine with 2 point/stabilizer blade, rigid cab elevation, 8 pneumatic tires, straight boom 21'4", angled stick 16'5" and wood grab GM 20B/2.03 yd<sup>2</sup>.

Weight 70,000 lb

### Dimensions

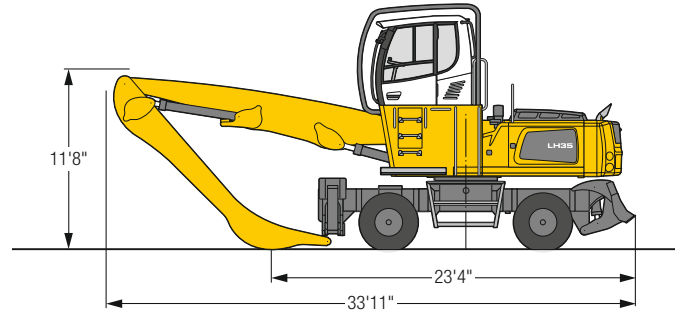

ft	Undercarriage	10 ft		15 ft		20 ft		25 ft		30 ft		35 ft		ft in		
40	Stabilizers raised (drive operation)	21,3*	21,3*	16,6*	16,6*									14,7*	14,7*	16'5"
	Stabilizers raised	21,3*	21,3*	16,6*	16,6*									14,7*	14,7*	
	2 pt. outriggers + blade down	21,3*	21,3*	16,6*	16,6*									14,7*	14,7*	
35	Stabilizers raised (drive operation)			19,7*	19,7*	15,0	16,6							10,9	11,4*	24'2"
	Stabilizers raised			19,7*	19,7*	16,7*	16,7*							11,4*	11,4*	
	2 pt. outriggers + blade down			19,7*	19,7*	16,7*	16,7*							11,4*	11,4*	
30	Stabilizers raised (drive operation)			20,2*	20,2*	15,3	16,8*	10,7	11,7					8,2	9,0	29'2"
	Stabilizers raised			20,2*	20,2*	16,8*	16,8*	13,3	14,5*					10,2*	10,2*	
	2 pt. outriggers + blade down			20,2*	20,2*	16,8*	16,8*	14,5*	14,5*					10,2*	10,2*	
25	Stabilizers raised (drive operation)			20,2*	20,2*	15,2	16,8	10,7	11,7	7,9	8,7			6,8	7,5	32'7"
	Stabilizers raised			20,2*	20,2*	16,8*	16,8*	13,3	14,4*	9,9	10,9			8,5	9,4	
	2 pt. outriggers + blade down			20,2*	20,2*	16,8*	16,8*	14,4*	14,4*	12,5*	12,5*			9,5*	9,5*	
20	Stabilizers raised (drive operation)			21,3*	21,3*	14,8	16,4	10,5	11,5	7,8	8,6			6,0	6,7	35'
	Stabilizers raised			21,3*	21,3*	17,4*	17,4*	13,1	14,4	9,8	10,8			7,5	8,3	
	2 pt. outriggers + blade down			21,3*	21,3*	17,4*	17,4*	14,6*	14,6*	12,5*	12,5*			9,3*	9,3*	
15	Stabilizers raised (drive operation)			20,1*	20,1*	22,2	23,4*	14,2	15,8	10,1	11,2	7,7	8,5	6,0	6,6	36'6"
	Stabilizers raised			20,1*	20,1*	23,4*	23,4*	17,8	18,3*	12,7	14,0	9,6	10,6	7,5	8,3	
	2 pt. outriggers + blade down			20,1*	20,1*	23,4*	23,4*	18,3*	18,3*	15,0*	15,0*	12,5*	12,5*	10,2*	10,2*	
10	Stabilizers raised (drive operation)			39,5*	39,5*	20,5	23,3	13,4	15,0	9,7	10,8	7,4	8,2	5,9	6,5	37'4"
	Stabilizers raised			39,5*	39,5*	25,7*	25,7*	16,8	18,7	12,1	13,4	9,3	10,3	7,4	8,1	
	2 pt. outriggers + blade down			39,5*	39,5*	25,7*	25,7*	19,1*	19,1*	15,2*	15,2*	12,4*	12,4*	9,9*	9,9*	
5	Stabilizers raised (drive operation)			8,3*	8,3*	18,9	21,5	12,6	14,1	9,3	10,3	7,2	8,0	5,8	6,4	37'5"
	Stabilizers raised			8,3*	8,3*	23,6	26,5*	15,8	17,7	11,6	12,9	9,0	9,9	7,2	8,0	
	2 pt. outriggers + blade down			8,3*	8,3*	26,5*	26,5*	19,3*	19,3*	15,0*	15,0*	11,9*	11,9*	9,2*	9,2*	
0	Stabilizers raised (drive operation)			8,0*	8,0*	17,8	20,4	12,0	13,5	8,9	9,9	7,0	7,8	5,7	6,3	36'7"
	Stabilizers raised			8,0*	8,0*	22,3	24,5*	15,0	16,9	11,2	12,4	8,7	9,7	7,1	7,8*	
	2 pt. outriggers + blade down			8,0*	8,0*	24,5*	24,5*	18,2*	18,2*	14,0*	14,0*	10,9*	10,9*	7,8*	7,8*	
-5	Stabilizers raised (drive operation)			17,4	19,9*	11,7	13,2	8,7	9,7	6,9	7,6			6,2	6,9	32'7"
	Stabilizers raised			19,9*	19,9*	14,6	15,6*	10,9	12,0*	8,6	9,0*			7,3*	7,3*	
	2 pt. outriggers + blade down			19,9*	19,9*	15,6*	15,6*	12,0*	12,0*	9,0*	9,0*			7,3*	7,3*	

Height Can be slewed through 360° In longitudinal position of undercarriage Max. reach \* Limited by hydr. capacity

The lift capacities on the stick end without attachment are stated in lb x 1,000 and are valid on a firm, level supporting surface with blocked oscillating axle. These capacities can be slewed through 360° with the undercarriage in the transverse position. Capacities in the longitudinal position of the undercarriage (+/- 15°) are specified over the steering axle with the stabilizers raised and over the rigid axle with the stabilizers down. Indicated loads based on the ISO 10567 standard and do not exceed 75% (according to EN 474-5 in drive operation only 60%) of tipping or 87% of hydraulic capacity. The lift capacity of the unit is limited by its stability, the lifting capability of the hydraulic elements, or the maximum permissible lifting capacity of the load hook.



# Choice of Cab Elevation

## Cab Elevation LFC (Rigid Elevation)

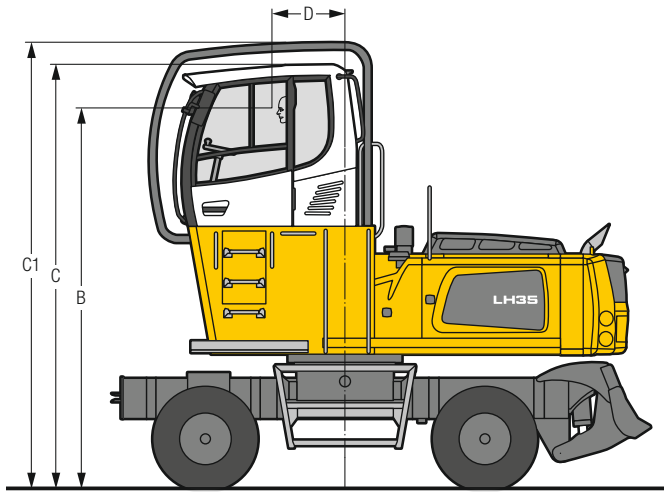

Increase type	LFC 120
Height	3'11"
B	13' 4"
C	14'11"
C1	15' 8"
D	2' 7"

A rigid cab elevation has a fixed eye level height. For a lower transport height, the shell of the cab can be removed and replaced by a transport device. On this machine dimension C is 11'11".

# Cab Protection

## Integral Guard

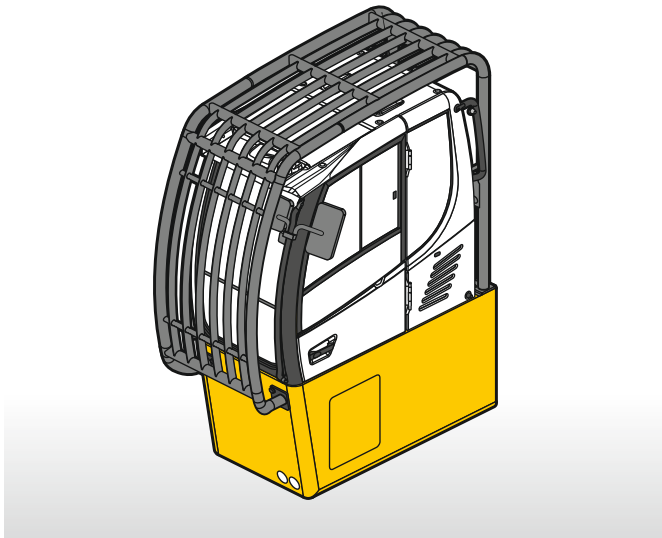

# Attachments

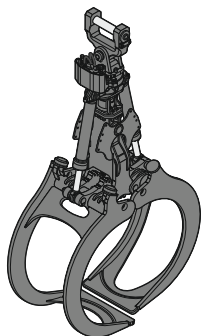

## Wood Grab

**Grab model GM 20B round-shaped** (complete overlapping, vertical cylinders)

Size	yd²	1.20	1.55	1.79	2.03	2.27
Cutting width	ft in	2'8"	2'8"	2'8"	2'8"	2'8"
Height of grab, closed	ft in	8'5"	8'9"	8'11"	9'3"	9'6"
Weight	lb	3,405	3,470	3,515	3,585	3,880

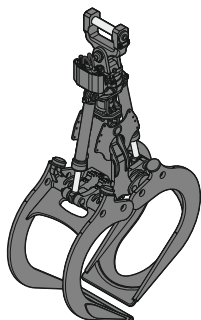

## Wood Grab

**Grab model GM 20B round-shaped** (complete overlapping, straight design, vertical cylinders)

Size	yd²	1.20	1.55	1.79	2.03
Cutting width	ft in	2'8"	2'8"	2'8"	2'8"
Height of grab, closed	ft in	8'4"	8'8"	8'11"	9'2"
Weight	lb	3,450	3,515	3,660	3,760

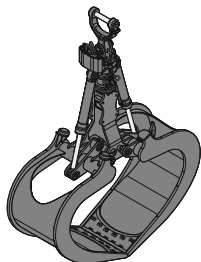

## Wood Grab

**Grab model GM 20C heart-shaped** (tip-to-tip closing, straight design, vertical cylinders)

Size	yd²	1.91	2.27
Cutting width	ft in	2'10"	2'10"
Height of grab, closed	ft in	9'6"	10'
Weight	lb	4,165	4,245



# Equipment

## Undercarriage

Stabilizer and dozer blade, rear	•
Stabilizer and dozer blade, rear and front	+
4-wheel steering	•
Trailer coupling	+
Mudguards (rear and front)	+
Shuttle axle lock, automatic	•
Outriggers front, stabilizer and dozer blade, rear	+
Tires, variants	+
Protection for travel drive	+
Protection for oscillating axle cylinders	+
Two lockable storage compartments	•
Undercarriage, variants	+

## Uppercarriage

Uppercarriage right side light, 1 piece, LED	•
Railing on uppercarriage	+
Main battery switch for electrical system	•
Amber beacon, at uppercarriage, LED double flash	+
Protection for counterweight (both sides)	+
Protection for headlights	+
Protection for uppercarriage (both sides)	+
Protection for rear lights	+
Tool equipment, extended	+

## Hydraulic System

Electronic pump regulation	•
Liebherr hydraulic oil from -4 °F to +104 °F	•
Liebherr hydraulic oil, biologically degradable	+
Magnetic rod in hydraulic tank	•
Bypass filter	+
Preheating hydraulic oil	+

## Engine

Fuel anti-theft device	+
Air pre-filter with dust discharge	+
Automatic engine shut-down (time adjustable)	+
Preheating fuel	+
Preheating coolant	+
Preheating engine oil*	+

## Cooling System

Radiator, large-mesh, for dust-intensive operation	•
Reversible fan drive, fully automatic	+
Protective grid in front of cooler intake	•

## Operator's Cab

Stabilizer, control lever, left console	+
Stabilizer, proportional control on left joystick	•
Front headlights integral protective grid, left side, halogen	+
Front headlights integral protective grid, left side, LED	+
Cab lights rear, halogen	+
Cab lights rear, LED	+
Cab lights front, halogen	•
Cab lights front, LED	+
Armrest adjustable	•
Slewing gear brake Comfort, button on the left or right joystick	•
Operator's seat Comfort	•
Operator's seat Premium	+
Driving alarm (acoustic signal is emitted during travel, can be switched ON/OFF)	+
Fire extinguisher	+
Horn, button on left joystick	•
Joystick and wheel steering (slim version)	•
Cab elevation, rigid (LFC)	•
Automatic air conditioning	•
LiDAT, vehicle fleet management	•
Proportional control	•
Radio Comfort, control via display with handsfree set	+
Preparation for radio installation	•
Amber beacon, on cabin, LED double flash	•
Windows made from impact-resistant laminated safety glass	+
Windscreen wiper, roof	+
Windshield wiper, entire windscreen	•
Integral guard	•
Sun visor	+
Left control console, folding	•

## Equipment

Boom lights, 2 pieces, halogen	•
Boom lights, 2 pieces, LED	+
Stick lights, 2 pieces, halogen	•
Stick lights, 2 pieces, LED	+
Boom shutoff (extend)	•
Filter system for attachment	+
Height limitation and stick shutoff, electronically	+
Boom cylinder cushioning	•
Stick camera (with separate monitor), bottom side, with protection	+
Liebherr multi coupling system	+
Pipe fracture safety valves hoist cylinders	•
Pipe fracture safety valves stick cylinders	•
Protection for piston rods, hoist cylinder	+
Protection for piston rods, stick cylinder	+
Overload warning device	+

## Complete Machine

<b>Lubrication</b>	
Lubrication undercarriage, manually – decentralized (grease points)	•
Central lubrication system for uppercarriage and equipment, automatically	•
Central lubrication system for undercarriage, automatically	+
Central lubrication system, extension for attachment	+
<b>Special coating</b>	
Special coating, variants	+
<b>Monitoring</b>	
Rear view monitoring with camera	•
Side view monitoring with camera	•

• = Standard, + = Option  
\* = country-dependent

Options and/or special equipments, supplied by vendors other than Liebherr, are only to be installed with the knowledge and approval of Liebherr in order to retain warranty.

# The Liebherr Group of Companies



## Diverse Product Range

The Liebherr Group is one of the largest construction equipment manufacturers in the world. Liebherr's quality products and services hold a high reputation in many industries. The wide range includes domestic appliances, aerospace and transportation systems, machine tools and maritime cranes.

## Exceptional Customer Benefit

Every product line provides a complete range of models in many different versions. With both their technical excellence and superior quality, Liebherr products offer customers the highest benefits in practical applications.

## State-of-the-art Technology

Liebherr attributes great importance to the product areas of core technology and components, in order to achieve its consistent, top-quality products. Important modules and components are developed and manufactured in-house, for instance, the entire drive and control technology for the construction equipment and mining trucks.

## Worldwide and Family-Owned

Hans Liebherr founded the Liebherr family company in 1949. Since that time, the enterprise has steadily grown to a group of more than 130 companies with more than 48,000 employees located on all continents. The corporate headquarters of the Group is Liebherr-International AG in Bulle, Switzerland. The Liebherr family is the sole owner of the company.

[www.liebherr.us](http://www.liebherr.us)

### **WARNING**

This product can expose you to chemicals including lead and lead compounds, which are known to the State of California to cause cancer and birth defects or other reproductive harm.  
For more information go to [www.P65warnings.ca.gov](http://www.P65warnings.ca.gov).

### **WARNING**

Breathing diesel engine exhaust exposes you to chemicals known to the State of California to cause cancer and birth defects or other reproductive harm.

- ▶ Always start and operate the engine in a well-ventilated area.
- ▶ If in an enclosed area, vent the exhaust to the outside.
- ▶ Do not modify or tamper with exhaust system.
- ▶ Do not idle the engine except as necessary.

For more information go to [www.P65warnings.ca.gov/diesel](http://www.P65warnings.ca.gov/diesel).