

---

# RL 46 Litronic RL 56 Litronic RL 66 Litronic

---

## LIEBHERR

Pipelayers



### Max. lift capacity

46,700 kg / 102,956 lb  
72,000 kg / 158,733 lb  
98,100 kg / 216,273 lb

### Engine SAE J1349

175 kW / 235 HP  
210 kW / 281 HP  
275 kW / 369 HP  
Tier 3 / EU Stage IIIA  
Tier 4f / EU Stage IV  
EU Stage V

### Engine ISO 9249

175 kW / 238 HP  
210 kW / 286 HP  
275 kW / 374 HP  
Tier 3 / EU Stage IIIA  
Tier 4f / EU Stage IV  
EU Stage V

## Performance

Power, stability and precision in a machine

## Efficiency

Cost efficiency comes as standard

## Reliability

Robust design in every respect

## Comfort

Optimised space, ergonomics and comfort

## Safety

Safety first!



### RL 46 Litronic

**Engine (ISO 9249)**

175 kW / 238 HP

Tier 3 / EU Stage IIIA

Tier 4f / EU Stage IV

**Operating weight**

34,800–35,100 kg

76,721–77,382 lb

**Engine (SAE J1349)**

175 kW / 235 HP

Tier 3 / EU Stage IIIA

Tier 4f / EU Stage IV

**Max. lift capacity**

46,700 kg / 102,956 lb



## RL 56 Litronic

**Engine (ISO 9249)**  
 210 kW / 286 HP  
 Tier 3 / EU Stage IIIA  
 Tier 4f / EU Stage IV /  
 EU Stage V  
**Operating weight**  
 46,050–46,280 kg  
 101,523–102,030 lb

**Engine (SAE J1349)**  
 210 kW / 281 HP  
 Tier 3 / EU Stage IIIA  
 Tier 4f / EU Stage  
 IV / EU Stage V  
**Max. lift capacity**  
 72,000 kg / 158,733 lb

## RL 66 Litronic

**Engine (ISO 9249)**  
 275 kW / 369 HP  
 Tier 3 / EU Stage IIIA  
 Tier 4f / EU Stage IV /  
 EU Stage V  
**Operating weight**  
 59,350–59,900 kg  
 130,844–132,057 lb

**Engine (SAE J1349)**  
 275 kW / 374 HP  
 Tier 3 / EU Stage IIIA  
 Tier 4f / EU Stage  
 IV / EU Stage V  
**Max. lift capacity**  
 98,100 kg / 216,273 lb

# Performance

---



## Power, stability and precision in one machine

Pipeline construction places the highest demands on production output and machine versatility – particularly under extreme conditions. Liebherr pipelayers are specially designed for use in challenging terrain. They combine a powerful stepless drive with the best manoeuvrability and maximum stability as well as maximum lifting power with precise control.

## High productivity

### Designed for pipeline construction

The compact construction, optimised centre of gravity and generously dimensioned hydraulic components, as well as the special width and length of the chassis, make Liebherr pipelayers into truly special machines for pipeline construction. That means: No compromises in terms of performance, efficiency and safety.

### Powerful drive

Liebherr diesel engines deliver sufficient power in every situation. Depending on requirements, operating modes are available for maximum performance or particularly fuel-efficient operation. The stepless hydrostatic drive operates automatically and adjusts the working speed to the required traction.

### Precise control

The special boom concept stabilises heavy loads in any position. With the Liebherr hydraulic control "Load Sensing" the joystick movements are sensitively and precisely converted into the corresponding working movements. Precise positioning is a decisive advantage – both when welding the pipe sections together and when lowering the pipe strings, as well as during repair work.

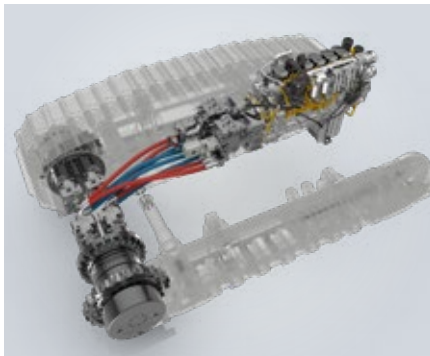

### Liebherr hydrostatic drive

- The automatic speed and torque adjustment always optimises the power flow to the chains with change in load
- This allows the machine to be steered accurately and powerfully. Chain slippage is minimised and the driver can concentrate fully on their work



### Liebherr boom concept

- Liebherr has been installing a compact and maintenance-free lifting cylinder, instead of a second winch, for years
- The hydraulically driven winch for the hook block has an emergency free fall device and can be infinitely adjusted. At standstill, a wear-free disc brake is automatically activated

## Versatile application

### Stable in any terrain

The layout of the drive components results in a very low centre of gravity while maximizing ground clearance. The continuous friction, smooth drive and boom control via a lifting cylinder prevent the machine from swinging up. This makes Liebherr pipelayers ideal for driving on steep terrain or for embankment work.

### Outstanding manoeuvrability

When working in confined spaces, the hydrostatic drive demonstrates another strength: all steering movements are quick and easy to make until turning on the spot. In conjunction with the boom even the heaviest of pipes can be easily swung to the side even on damp and difficult ground.

### Extensive range of equipment versions

A variety of boom lengths is available for all types of Liebherr pipelayers. These enable even larger work areas to be covered. In addition to an optional extended drawbar, hydrostatic cable winches can be fitted to the rear of the main frame. It is also possible to operate generators and use pipe facing machines and telescopic cranes. This increases the versatility of the machine on the construction site.



### Minimal ground pressure

- Liebherr pipelayers have long undercarriages and wide track shoes to minimise ground pressure
- This makes it possible to work very close to the pipeline trenches, which in turn allows the use of higher lifting capacities

# Efficiency

---



## Cost efficiency and always ready for operation

In addition to the initial cost of acquisition, many other parameters are crucial to the profitability of construction machinery. This is why in the design of Liebherr pipelayers particular attention is paid to ease of maintenance, increased service life of components, reduced service costs and minimum fuel consumption. All changeover and construction site transports are performed quickly and with minimal effort.

## Trimmed for efficiency

### State-of-the-art engine and exhaust technology

Liebherr diesel engines' very high levels of efficiency result from a combination of constantly low engine speed, Common-Rail injection and optimised combustion temperature. Exhaust gas after-treatment for emission Stage IV / Tier 4 final is achieved by selective catalytic reduction by injection of urea (AdBlue®). A diesel particulate filter is not necessary.

### Minimal fuel consumption

The stepless hydrostatic drive and demand-controlled cooling further reduce fuel consumption. The same applies to the load sensing by the working hydraulics, where only the exact amount of oil required is delivered. This technology also protects the hydraulic components.

### Long oil change intervals

Liebherr's oils and lubricants are specially tailored to the harsh operating conditions of pipelayers. Due to their special properties, changing intervals up to four times longer than with standard oils can be achieved. This reduces service costs, reduces the amount of oil used and protects the environment. As an option, the hydraulic oil level can be read directly from the display.

## Attractive service concept

### Economical components

The main components of Liebherr pipelayers are identical to those of the crawler dozers. This guarantees the highest quality standards and significantly simplifies maintenance and spare parts supply. The batteries, which are resistant to temperatures down to -40 °C, can optionally be pre-heated and insulated and therefore require very little maintenance.

### Fast and uncomplicated service

All the diesel engine's service points are attached on one side of the machine and easily accessible. Dust extraction from the air filter is automatic. The reinforced front radiator guard can be pivoted, just like the fan. A series of warning lights on the cab display indicate the need for a service.

### Simple to change over – effortless to transport

Boom, hook block and counterweight can be easily and quickly disassembled and stowed away. This enables cost effective transportation of the pipelayer to the next site by truck. Additional hydraulic connections and an intelligent basic engineering design allow retrofitting and change over for transportation of welding tents, the operation of a pipe facing machine or for mobile power generation.



### Ideal accessibility

- Wide-opening engine compartment doors and a standard tiltable cabin provide easy access for all service and maintenance
- On-board electronics, tools and other service points are housed in easily accessible sealed containers and protected accordingly



### Simple boom mounting

- To mount or dismount the boom, the lifting cylinder is first lowered to ground level and the locking bolt is then released with a simple sliding system
- Now the boom can be removed and the cylinder folded back into the transportation position



### Always informed with LiDAT

- The Liebherr LiDAT data transmission and fleet management system contributes to effective fleet management
- Utilising the latest communication technology, LiDAT provides comprehensive operational data, for efficient machine management, optimization of resources, and remote monitoring

# Reliability

---



## Robust and durable in every respect

Pipelayers are the core machinery for laying pipelines. Therefore, their operational readiness is critical in meeting tight schedules. The Liebherr pipelayers' mature technology, innovative attention to detail and high-quality materials and workmanship together ensure maximum operational availability. This applies to their day-to-day operation in the toughest and in all weather conditions as well as in terms of long service life.



## Sophisticated engineering design

### Key technologies developed in-house

Based on decades of experience in the development, design and manufacture of components, Liebherr offers maximum reliability. Key components such as diesel engines, transfer boxes, hydraulic pumps and cylinders, final drives and electronics are manufactured in-house and their compatibility is therefore optimised.

### Torsionally rigid main frame

Through use of the highest grades of steel and box construction, the forces applied to the frame are perfectly absorbed. This allows the main frame to withstand the highest continuous load. Components that are particularly subject to stresses are manufactured in cast steel.

### Wear-free drive concept

The proven hydrostatic drive dispenses with torque converters, manual transmissions and differential steering or steering clutches. The high-quality hydraulic pumps and engines operate almost entirely without mechanical wear and are particularly safe in operation. The large dimension final drives are also extremely robust and have heavy duty duo cone seals with leakage control.

## Designed for maximum service life

### Durable engines and smart cooling system

Liebherr diesel engines, with their robust design and low rated speed, guarantee maximum operational security. Demand controlled, hydraulically driven cooling radiators regulate the operating temperature independently of the engine speed. Shorter warm-up phases and reliable cooling are guaranteed, even in dust intensive applications. An air prefilter or a reversible fan can be used for particularly critical environmental conditions.

### Always operationally ready even at -40 °C

Liebherr pipelayers can be equipped with a variety of cold protection measures for operation down to -40 °C: Engine and battery preheating, electrically heated fuel prefilter, auxiliary cabin heating, insulating glazing and other cold-resistant components.

### Practical advice for practical operation

In every situation, Liebherr customer service offers fast solutions to problems and practical assistance in making decisions. This applies to service agreements as well as to repair options or original parts management. Thanks to tailor-made inspection programmes, all maintenance measures can be optimally planned.



### Endurance testing of components

- Engineering design uses state-of-the-art development software to accurately specify and design components
- This is followed by extensive long term field tests. Only parts that meet the high Liebherr's high quality standard are used in the machines



### High quality finish

- All cable harnesses are protected with wear resistant PVC coated yarn and Teflon core. All hydraulic hoses are abrasion resistant
- This largely avoids mechanical damage and the cables are optimally protected against moisture



### Faster service

- Liebherr's spare parts service works around the clock for its customers. Regardless of the pipelayer's location, spare parts, consumables and accessories can be ordered online from the Liebherr service partner at any time

# Comfort

---



## The best operating conditions produce the best working performance

The driver can only work at their full potential under optimum conditions. This is why the exceptional comfort of the Liebherr workplace makes it stand out. The generously proportioned, ergonomic and quiet cabin provides perfect conditions for fatigue free and focused operation with the best visibility. It has a modern display and a comprehensive range of assistance systems to support the driver in all activities.

## Premium class cabin

### Ergonomic and clear design

The sophisticated design of the driver's seat creates the ideal conditions for relaxed and productive operation even for a prolonged period. All instruments and controls are clearly arranged and within easy reach. The seat, armrests, footrest and joystick can be individually adjusted to suit the driver.

### Convenience in daily use

In addition to a variety of seat variants, Liebherr pipelayers offer additional features for driver comfort including a backrest extension, a spacious storage compartment, optimum interior lighting, sliding windows for the right side wind-screens, 12 V plug, coat hooks and radio preparation. Despite the compactness and range of controls, the cabin offers sufficient space to accommodate drivers of all builds.

### Quiet and dust-free

Due to the effective sound insulation and the modern, quiet diesel engines, the Liebherr pipelayers' noise levels are excellent and well below statutory requirements. The pressurised cabin keeps the driver's workplace free of dust from the surrounding environment.

## Productive working environment

### Single-lever control

A single control lever both for the boom together with the winch and for the complete travel drive allows easy and precise control even in confined spaces. As an option, an inch brake pedal for even finer speed control can be ordered in addition to the joystick for the travel drive. This logical operating concept therefore requires a minimum amount of training.

### Everything clearly in view

An unobstructed view of the load to be moved, as well as of the ground and the other pipelayers in the group, is critical for productivity and safety. Liebherr pipelayers stand out due to their sophisticated design, the generous all-round windscreens and the driver's seat rotated 15° to the boom. Come rain or shine, the best visibility is always ensured thanks to tinted glass, the roller blinds and windscreen wipers for all key surfaces.

### A pleasant cabin environment

The standard powerful air conditioning system has a large number of individually adjustable air nozzles. These supply the cabin space with fresh air evenly and maintain a constant temperature level from head to foot. For low temperature applications, a programmable auxiliary cabin heater is available.



### Individual adjustment

- At the touch of a button, the driver can adjust a wide range of machine settings. For example, the response of the travel drive can be set exactly to his needs
- All individual settings are retained after restarting the machine thanks to the memory function

### Always up to date

- The touch control display is intuitive to use and keeps the driver informed of all the key operating data. It also acts as a monitor for the rear view camera
- Control lights and indicators provide extensive information from fuel tank level, operating hours and battery charge through to air filter contamination, hydraulic oil temperature and pump replenishing pressure, etc.

### Perfect all-round visibility

- Visibility for the working area is optimised by the pivoting cable guide pulley and for the boom tip and the hook block by the roof window
- A camera is not necessary for a perfect view of the right side of the machine due to the absence of a second pulley. Visibility on both drive sides of the Liebherr pipelayer is clear due to the engineering design

# Safety

---



## Safety first!

Despite the highest demands on performance and efficiency under the most difficult conditions, safety is still of paramount importance at Liebherr. That is why all pipelayers are based on an advanced safety concept that sets the standard in pipeline construction. Safety functions are in place for every critical situation, whether that be cabin rollover protection, parking brake, hoist limit shutoff, free fall device or load moment limitation, to name but a few.

## Workplace safety

### Cabin with integrated ROPS

When it comes to safety, the driver's cabin meets the highest standards. It is equipped with integrated ROPS and roof windows made of laminated safety glass as standard. This ensures full visibility with maximum protection. As an option, a FOPS grille is available.

### Safety is built into the detail

Access to the cabin is through a series of non-slip foot rails and grab handles. The seat contact switch detects whether the driver is present and activates or deactivates the machine accordingly. A panorama mirror inside or additional external rear-view mirrors assist the driver in reversing. Individually adjustable headlamps guarantee excellent illumination of the entire working area even at night in multi-shift operation.

### Always balanced

All movements of the machine can be controlled without having to transfer grip to other operating levers. The counterweight can be extended at any time using its own adjustment lever. In a dangerous situation, the free fall function, fitted as standard, and the optional load moment limitation keep the pipelayer balanced. This allows the driver to maintain focus on the load to be moved and the surrounding work environment.

## Additional protective measures

### Personal protection in the working environment

There are always people in the immediate vicinity of the pipelayer, especially on cramped construction sites or when loading. For such situations, there it is possible to equip the machines with an amber beacon, rear view camera, back-up alarm or with a 270° camera. In addition, all pipelayers have a hydraulic line pipe rupture protection which prevents the boom from dropping in the event of an emergency.

### Preventing damage to materials

Robust rubber strips are bolted to the boom and protect the pipes being laid from damage. When raising the hook block, an automatic shutdown occurs shortly before the counter roll stop. This hoist limit shutoff prevents damage to materials during day-to-day work.

### Lifting cylinder for greater safety

The boom concept incorporates a lifting cylinder that provides several advantages related to safety. Firstly, in extreme cases, it prevents unwanted collapse and consequently complete tilting of the pipelayer. Secondly, the lifting cylinder holds the boom in a stable position with each movement and allows a faster response – for example, when driving under power lines.



### Reliable load moment limitation

- The new Liebherr load moment limitation (LMB) provides the driver with information via visual and acoustic displays inside and outside the cab at all times
- If the machine moves at the limit, the system only permits movements that increase the stability of the pipe layer

### Also safe in an emergency

- If the driver has to lower the load quickly to avoid an accident, it is possible to switch the winch to freewheel
- If it is not possible to get out through the cabin door in an emergency situation, the driver can use an emergency hammer to break the side or rear windscreen and get to safety

### Movements on slopes

- Due to the self-locking of the hydrostatic drive, Liebherr pipelayers can be brought to a standstill at any time, even on slopes
- In this case, the parking / safety brake activates automatically. This prevents rolling away on a slope

# Technical data RL 46



## Engine

<b>Liebherr Diesel engine</b>	D 934 A7 Emission regulations according to 97/68/EC, 2012/46/EU Stage IIIA / Stage IV, EPA/CARB Tier 3 / Tier 4f
<b>Rated power</b> ISO 9249 SAE J1349	175 kW / 238 HP 175 kW / 235 HP
<b>Rated speed</b>	1,900 rpm
<b>Displacement</b>	7.01 / 427 in <sup>3</sup>
<b>Design</b>	4 cylinder in-line engine, water-cooled, turbocharged, air-to-air intercooler
<b>Injection system</b>	Direct fuel injection, Comm / ft-inon Rail, electronic control
<b>Lubrication</b>	Pressurised lube system, engine lubrication guaranteed for inclinations up to 45°
<b>Operating voltage</b>	24 V
<b>Alternator</b>	140 A
<b>Starter</b>	7.8 kW / 11 HP
<b>Batteries</b>	2 x 180 Ah / 12 V
<b>Air cleaner</b>	Dry-type air cleaner with pre-cleaner, main and safety elements, control light in the operator's cab
<b>Cooling system</b>	Combi radiator, comprising radiators for water, hydraulic oil and charge air. Hydrostatic fan drive.



## Hydraulics

<b>Hydraulic system</b>	Load sensing (demand controlled)
<b>Pump type</b>	Swash plate piston pump
<b>Pump flow max.</b>	240 l/min. / 63.4 gpm
<b>Pressure limitation</b>	280 bar / 4,060 psi
<b>Control valve</b>	3 circuits, expandable to 6
<b>Filter system</b>	Return filter with magnetic rod in the hydraulic tank
<b>Control</b>	Single joystick for hoist winch and adjustable boom cylinder, free all device of hook in case of danger. Further single joystick for counterweight.



## Travel drive, control

<b>Transmission system</b>	Infinitely variable hydrostatic travel drive, independent drive for each track
<b>Travel speed*</b> Speed range 1 (reverse): Speed range 2 (reverse): Speed range 3 (reverse):	Continuously variable 0-4.0 km/h / 2.5 mph (4.5 km/h / 2.8 mph) 0-6.0 km/h / 3.7 mph (8.0 km/h / 4.9 mph) 0-10.5 km/h / 6.5 mph (10.5 km/h / 6.5 mph) *Travel speed ranges can be set on the travel joystick (memory function)
<b>Electronic system</b>	The electronic system automatically adjusts travel speed and drawbar pull to match changing load conditions
<b>Steering</b>	Hydrostatic
<b>Service brake</b>	Hydrostatic (self-locking), wear-free
<b>Parking brake</b>	Multi-disc brake, wear-free, automatically applied with neutral joystick position
<b>Cooling system</b>	Integrated oil cooler, hydrostatic fan drive and thermostatically controlled
<b>Filter system</b>	Micro cartridge filter in the replenishing circuit
<b>Final drive</b>	Combination spur gear with planetary gear, double-sealed (duo cone seals) with electronic seal-integrity indicator
<b>Control</b>	Single joystick for all travel and steering functions



## Operator's cab

<b>Cab</b>	Resiliently mounted cab with positive pressure ventilation, can be tilted with hand pump 40° to the rear. With integrated ROPS Rollover Protective Structure (EN ISO 3471)
<b>Operator's seat</b>	Air suspended comfort seat, fully adjustable
<b>Monitoring</b>	Touch screen: display of current machine information, automatic monitoring of operating conditions, individual setting of machine parameters
<b>Vibration emission</b> Hand / arm vibrations Whole-body vibrations	< 2.5 m/s <sup>2</sup> , according with ISO 5349-1:2001 < 0.5 m/s <sup>2</sup> , complies with technical report ISO/TR 25398:2006
<b>Measuring inaccuracy</b>	According with standard EN 12096:1997

## Undercarriage

Design	Track frame, rigid
Mounting	Separate pivot
Track chains	Lubricated, single-grouser shoes, tensioning via steel spring and grease tensioner
Links, each side	43
Track rollers, each side	8
Carrier rollers, each side	2
Sprocket segments, each side	5
Track shoes, standard	711 mm / ft-in / 28"
Track shoes left, optional	914 mm / ft-in / 36"

## Sound levels

Operator sound exposure ISO 6396	
$L_{pA}$ (in the cab)	78 dB(A)
Exterior sound pressure 2000/14/EC	
$L_{WA}$ (to the environment)	108 dB(A)

## Refill capacities

Urea tank	50l / 13.2 gal
Fuel tank	430l / 113.5 gal
Cooling system	51l / 13.5 gal
Engine oil, with filter	29l / 7.7 gal
Hydraulic tank	111l / 29.3 gal
Final drive, left	21l / 5.5 gal
Final drive, right	14l / 3.7 gal

## Dawbar pull

Max.	281 kN
at 1.5 km/h / 0.9 mph	281 kN
at 3.0 km/h / 1.9 mph	180 kN
at 6.0 km/h / 3.7 mph	90 kN
at 9.0 km/h / 5.6 mph	60 kN

## Hydraulic winch

Hoist winch	Variable flow hydraulic pump
Safety brake	Spring-loaded disk brake holds the load safely in any position
Drum diameter	254 mm / ft-in / 10"
Drum length	279 mm / ft-in / 10.98"
Flange diameter	610 mm / ft-in / 24.02"
Cable diameter	20 mm / ft-in / 0.8"
Cable length	65 m / 71.08 yd
Hook block	2 sheaves
Hook speed (up, down)	0-30.5 m/min. / 0-100 ft/min.
Security	Free fall device

# Dimensions and weights RL 46

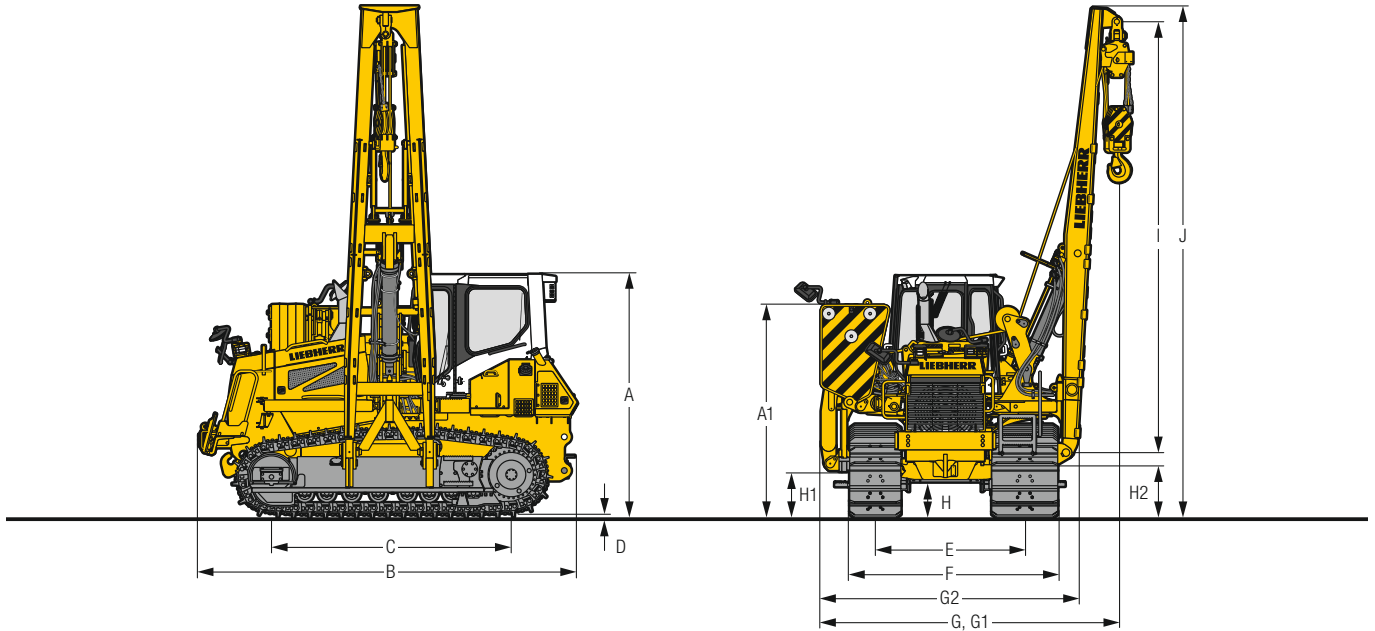

## Dimensions

Boom		Standard 6,000 mm / ft-in	Optional 7,320 mm / ft-in
A	Height over cab	mm / ft-in	3,365 / 11'0"
A <sub>1</sub>	Height over counterweight	mm / ft-in	2,876 / 9'5"
B	Overall length	mm / ft-in	5,146 / 16'11"
C	Length of track on ground	mm / ft-in	3,315 / 10'11"
D	Height of grousers	mm / ft-in	71.5 / 2.81"
E	Track gauge	mm / ft-in	2,075 / 6'10"
F	Total width over undercarriage	mm / ft-in	2,786 / 9'2" <sup>1)</sup>
G	Width (counterweight retracted)	mm / ft-in	4,104 / 13'6"
G <sub>1</sub>	Width (counterweight extended)	mm / ft-in	5,783 / 19'
G <sub>2</sub>	Width (lower machine area, counterweight folded in)	mm / ft-in	3,565 / 11'8"
H	Ground clearance	mm / ft-in	534 / 1'9"
H <sub>1</sub>	Ground clearance of console	mm / ft-in	646 / 2'1"
H <sub>2</sub>	Ground clearance of boom	mm / ft-in	660 / 2'2"
I	Boom length	mm / ft-in	6,000 / 19'8"
J	Total height	mm / ft-in	6,999 / 23'
K	Distance (outer edge of chain link to hook)	mm / ft-in	1,178 / 3'10"
	Operating weight	kg / lb	34,800 / 76,721
	Counterweight without frame	kg / lb	5,030 / 11,089
	Counterweight	kg / lb	7,222 / 15,922
	Weight of standard boom	kg / lb	1,710 / 3,770
			1,975 / 4,354

<sup>1)</sup> Track shoes with 914 mm / ft-in / 36": 2,887 mm / ft-in / 9'6".



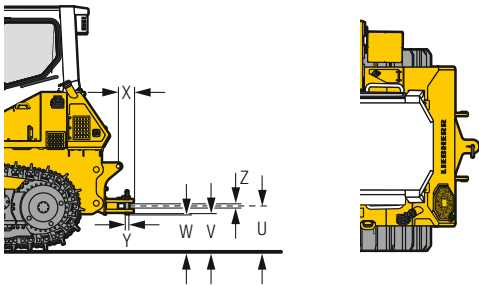

## Drawbar

Boom		rigid	
U	Height of jaw	mm / ft-in	544 / 1'9"
V	Ground clearance below drawbar	mm / ft-in	456 / 1'6"
W	Ground clearance below drawbar suspension	mm / ft-in	431 / 1'5"
X	Additional length	mm / ft-in	400 / 1'4"
Y	Socket pin diameter	mm / ft-in	50 / 1.97"
Z	Jaw opening	mm / ft-in	95 / 3.74"
	Weight	kg / lb	253 / 558

# Transport dimensions and weights RL 46

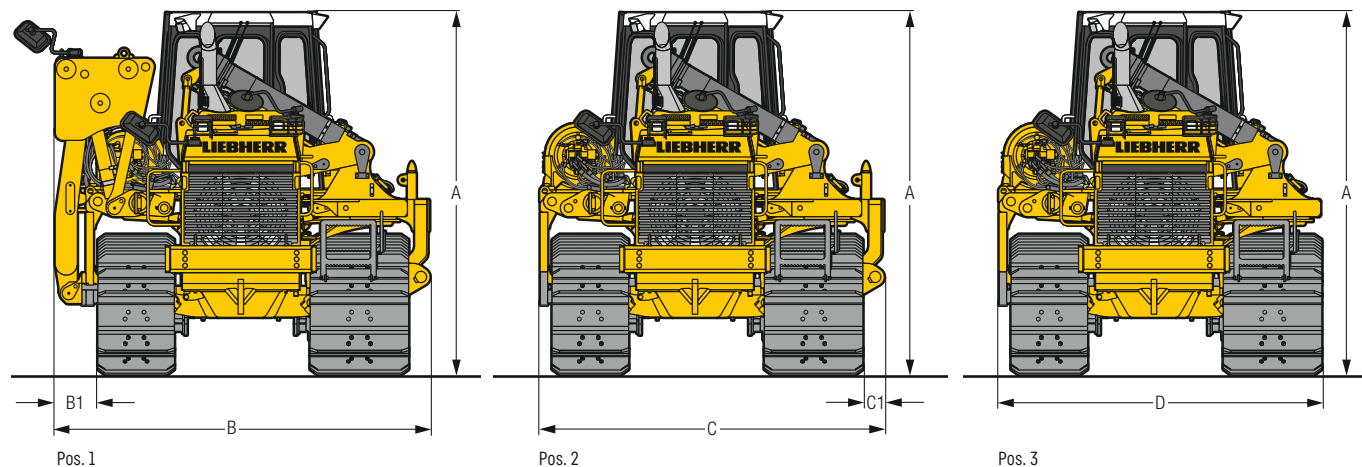

## Transport dimensions

		displayed position
<b>A</b>	<b>Total height</b>	mm / ft-in
<b>B</b>	<b>Overall width</b>	3,365 / 11'0"
<b>B<sub>1</sub></b>	<b>Width (from console to left track)</b>	mm / ft-in
	<b>Weight (Pos. 1)</b>	3,561 / 11'8" <sup>1)</sup>
<b>C</b>	<b>Overall width</b>	395 / 1'4"
<b>C<sub>1</sub></b>	<b>Width (from console to right track)</b>	mm / ft-in
	<b>Weight (Pos. 2)</b>	28,374 / 62,553
<b>D</b>	<b>Overall width</b>	mm / ft-in
	<b>Weight (Pos. 3)</b>	3,274 / 10'9" <sup>2)</sup>
		293,5 / 11.56" <sup>1)</sup>
		26,574 / 58,543
		2,980 / 9'9" <sup>1)</sup>
		26,084 / 57,505

<sup>1)</sup> Track shoes with 711 mm / 28". Track shoes left optional with 914 mm / 36": 2,997 mm / 9'10"

<sup>2)</sup> Track shoes with 711 mm / 28". Track shoes left optional with 914 mm / 36": 192 mm / 0'8"

# Lift capacity RL 46 (ISO 8813)

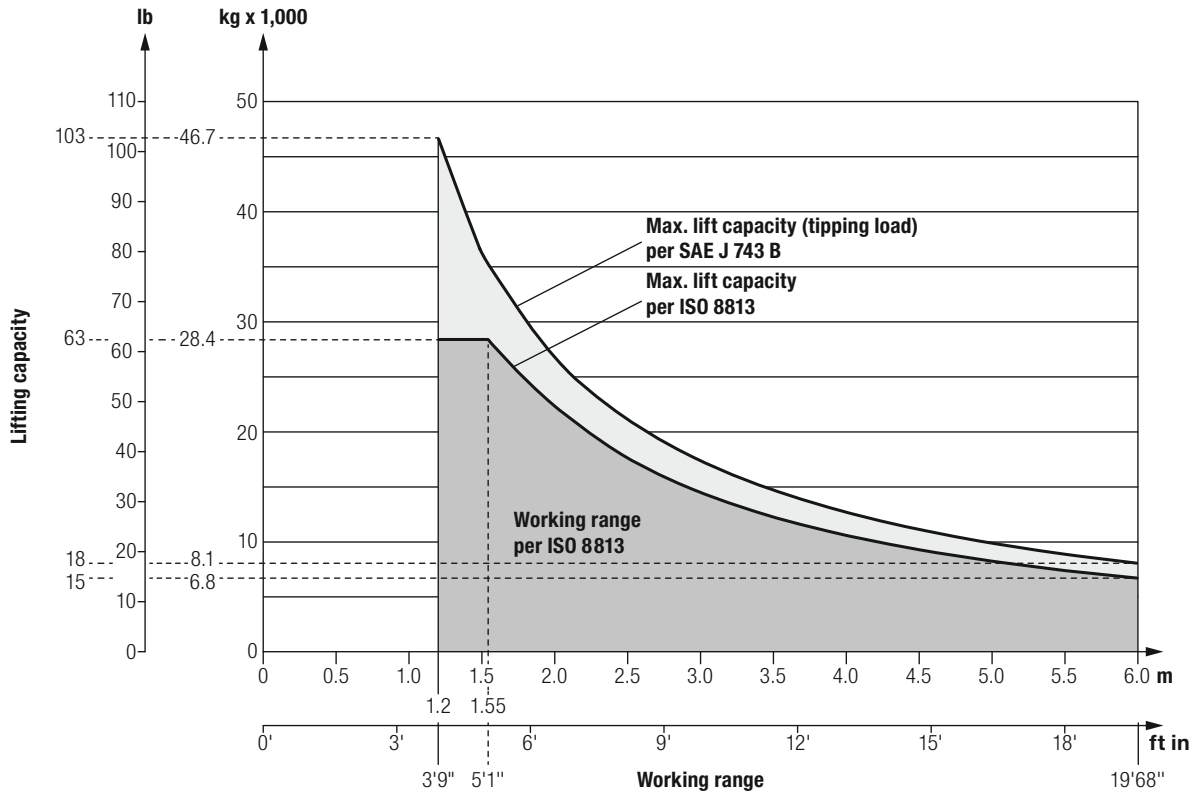

# Ground pressure RL 46 (ISO 8813)

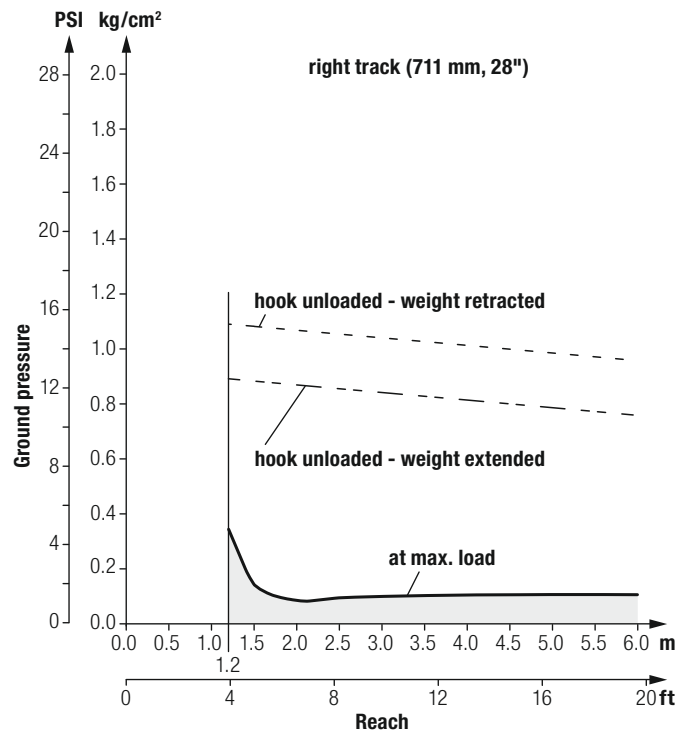
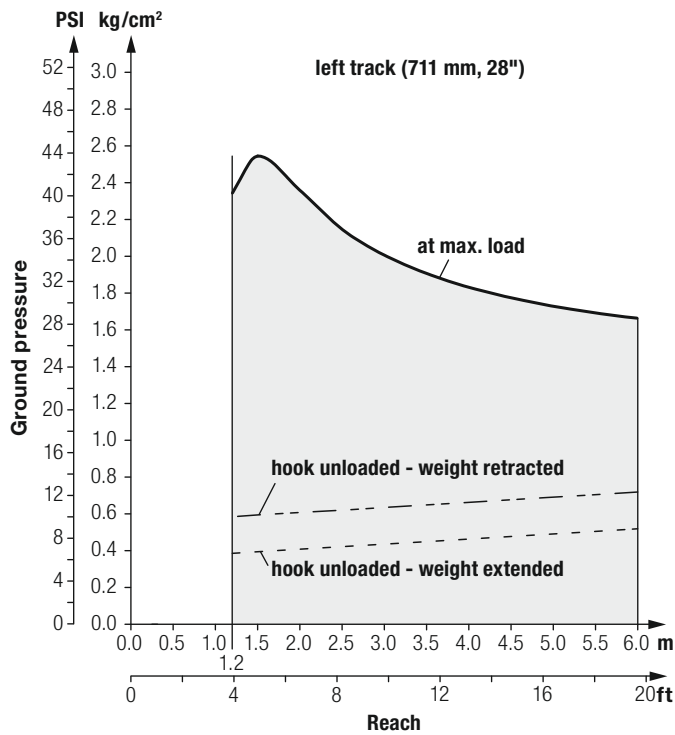

# Technical data RL 56



## Engine

<b>Liebherr Diesel engine</b>	D 936 A7 Emission regulations according to 97/68/EC, 2004/26/EG Stage IIIA/Stage V, EPA/CARB Tier 3 / Tier 4f
<b>Rated power</b> ISO 9249 SAE J1349	210 kW / 286 HP 210 kW / 281 HP
<b>Rated speed</b>	1,800 rpm
<b>Displacement</b>	10.5 l / 641 in <sup>3</sup>
<b>Design</b>	6 cylinder in-line engine, water-cooled, turbocharged, air-to-air intercooler
<b>Injection system</b>	Direct fuel injection, Common Rail, electronic control
<b>Lubrication</b>	Pressurised lube system, engine lubrication guaranteed for inclinations up to 45°
<b>Operating voltage</b>	24 V
<b>Alternator</b>	140 A
<b>Starter</b>	7.8 kW / 11 HP
<b>Batteries</b>	2 x 180 Ah / 12 V
<b>Air cleaner</b>	Dry-type air cleaner with pre-cleaner, main and safety elements, control light in the operator's cab
<b>Cooling system</b>	Combi radiator, comprising radiators for water and charge air. Hydrostatic fan drive



## Hydraulics

<b>Hydraulic system</b>	Load sensing (demand controlled)
<b>Pump type</b>	Swash plate piston pump
<b>Pump flow max.</b>	283 l/min. / 74.7 gpm
<b>Pressure limitation</b>	280 bar / 4,060 psi
<b>Control valve</b>	3 circuits, expandable to 6
<b>Filter system</b>	Return filter with magnetic rod in the hydraulic tank
<b>Control</b>	Single joystick for hoist winch and adjustable boom cylinder, free all device of hook in case of danger. Further single joystick for counterweight.



## Travel drive, control

<b>Transmission system</b>	Infinitely variable hydrostatic travel drive, independent drive for each track
<b>Travel speed *</b>	Continuously variable
Speed range 1 (reverse):	0-4.0 km/h / 2.5 mph (4.5 km/h / 2.8 mph)
Speed range 2 (reverse):	0-6.5 km/h / 4.0 mph (8.0 km/h / 4.9 mph)
Speed range 3 (reverse):	0-10.5 km/h / 6.5 mph (10.5 km/h / 6.5 mph)
	* Travel speed ranges can be set on the travel joystick (memory function)
<b>Electronic system</b>	The electronic system automatically adjusts travel speed and drawbar pull to match changing load conditions
<b>Steering</b>	Hydrostatic
<b>Service brake</b>	Hydrostatic (self-locking), wear-free
<b>Parking brake</b>	Multi-disc brake, wear-free, automatically applied with neutral joystick position
<b>Cooling system</b>	Separate oil cooler, hydrostatic fan drive and thermodynamically controlled
<b>Filter system</b>	Micro cartridge filter in the replenishing circuit
<b>Final drive</b>	Combination spur gear with planetary gear, double-sealed (duo cone seals) with electronic seal-integrity indicator
<b>Control</b>	Single joystick for all travel and steering functions



## Operator's cab

<b>Cab</b>	Resiliently mounted cab with positive pressure ventilation, can be tilted with hand pump 40° to the rear. With integrated ROPS Rollover Protective Structure (EN ISO 3471)
<b>Operator's seat</b>	Air suspended comfort seat, fully adjustable
<b>Monitoring</b>	Touch screen: display of current machine information, automatic monitoring of operating conditions, individual setting of machine parameters
<b>Vibration emission</b>	
Hand / arm vibrations	< 2,5 m/s <sup>2</sup> , according with ISO 5349-1:2001
Whole-body vibrations	< 0,5 m/s <sup>2</sup> , complies with technical report ISO/TR 25398:2006
Measuring inaccuracy	According with standard EN 12096:1997

## Undercarriage

Design	Track frame, rigid
Mounting	Elastic components at a separate pivot
Track chains	Lubricated, single-grouser shoes, tensioning via steel spring and grease tensioner
Links, each side	45
Track rollers, each side	9
Carrier rollers, each side	2
Sprocket segments, each side	5
Track shoes	914 mm / 36"

## Sound levels

Operator sound exposure ISO 6396	
$L_{pA}$ (in the cab)	78 dB(A)
Exterior sound pressure 2000/14/EC	
$L_{WA}$ (to the environment)	108 dB(A)

## Refill capacities

Fuel tank	505l / 133.3 gal
Cooling system	60l / 15.08 gal
Engine oil with filter	43l / 11.4 gal
Splitter box	8.5l / 2.2 gal
Hydraulic tank	112l / 29.6 gal
Final drive, each side	19.5l / 5.1 gal

## Dawbar pull

Max.	387 kN
at 1.5 km/h / 0.9 mph	387 kN
at 3.0 km/h / 1.9 mph	216 kN
at 6.0 km/h / 3.7 mph	108 kN
at 9.0 km/h / 5.6 mph	72 kN

## Hydraulic winch

Hoist winch	Variable flow hydraulic pump
Safety brake	Spring-loaded disk brake holds the load safely in any position
Drum diameter	254 mm / 10"
Drum length	274 mm / 10.79"
Flange diameter	610 mm / 24.02"
Cable diameter	20 mm / 0.8"
Cable length	80 m / 87.49 yd
Hook block	3 sheaves
Hook speed (up, down)	0-20.0 m/min. / 0-66 ft/min.
Security	Free fall device

# Dimensions and weights RL 56

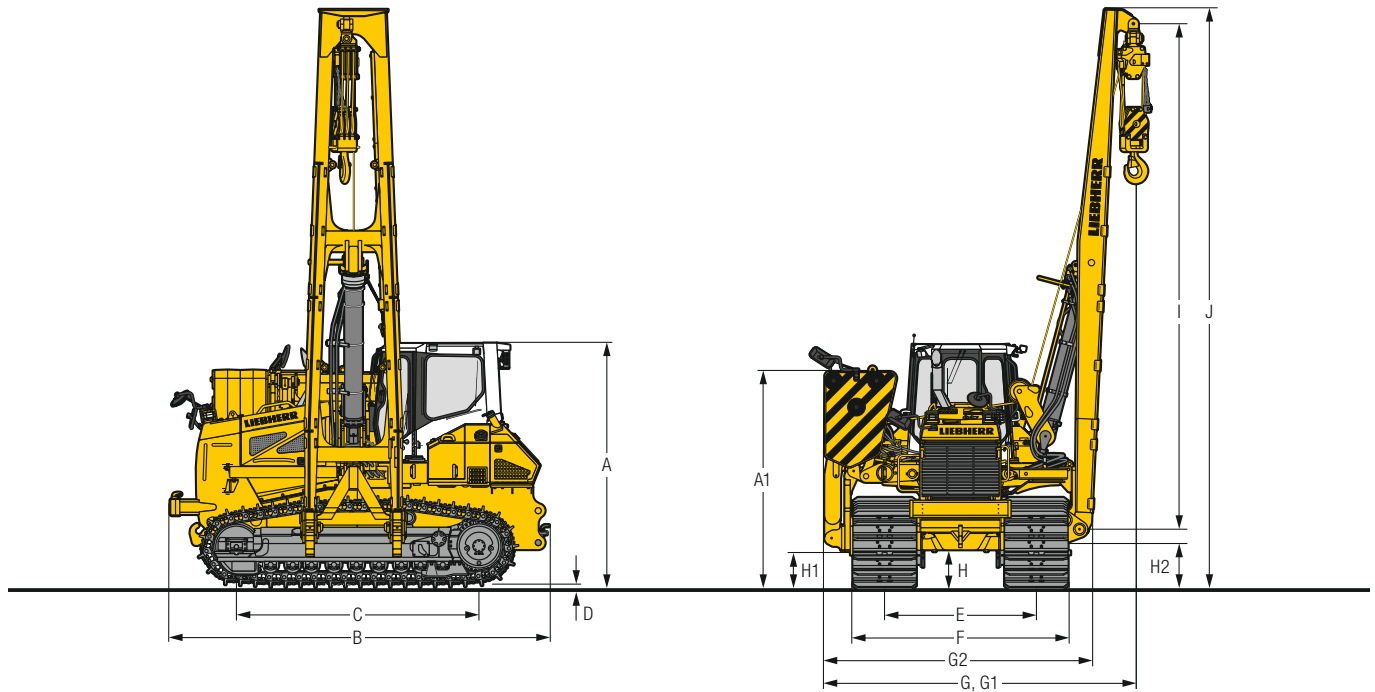

## Dimensions

Boom		Standard 7,300 mm / ft-in	Optional 8,500 mm / ft-in
A	Height over cab	mm / ft-in	3,529 / 11'7"
A <sub>1</sub>	Height over counterweight	mm / ft-in	3,068 / 10'1"
B	Overall length	mm / ft-in	5,446 / 17'10"
C	Length of track on ground	mm / ft-in	3,504 / 11'6"
D	Height of grousers	mm / ft-in	71 / 2'8"
E	Track gauge	mm / ft-in	2,180 / 7'2"
F	Total width over undercarriage	mm / ft-in	3,094 / 10'5"
G	Width (counterweight retracted)	mm / ft-in	4,450 / 14'7"
G <sub>1</sub>	Width (counterweight extended)	mm / ft-in	6,209 / 20'4"
G <sub>2</sub>	Width (lower machine area, counterweight folded in)	mm / ft-in	3,850 / 12'8"
H	Ground clearance	mm / ft-in	572 / 1'11"
H <sub>1</sub>	Ground clearance of console	mm / ft-in	651 / 2'2"
H <sub>2</sub>	Ground clearance of boom	mm / ft-in	548 / 1'10"
I	Boom length	mm / ft-in	7,300 / 23'11"
J	Total height	mm / ft-in	8,281 / 27'2"
K	Distance (outer edge of chain link to hook)	mm / ft-in	1,200 / 3'11"
	Operating weight	kg / lb	46,050 / 101,523
	Counterweight without frame	kg / lb	9,534 / 21,019
	Counterweight	kg / lb	12,730 / 28,065
	Weight of standard boom	kg / lb	2,264 / 4,991
			2,497 / 5,505

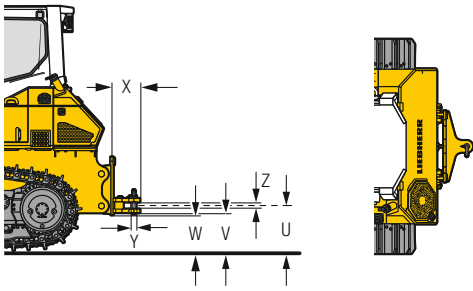

## Drawbar

Boom		rigid	
U	Height of jaw	mm / ft-in	576 / 1'11"
V	Ground clearance below drawbar	mm / ft-in	474 / 1'7"
W	Ground clearance below drawbar suspension	mm / ft-in	424 / 1'5"
X	Additional length	mm / ft-in	435 / 1'5"
Y	Socket pin diameter	mm / ft-in	60 / 2.36"
Z	Jaw opening	mm / ft-in	105 / 4.13"
	Weight	kg / lb	460 / 1,014

# Transport dimensions and weights RL 56

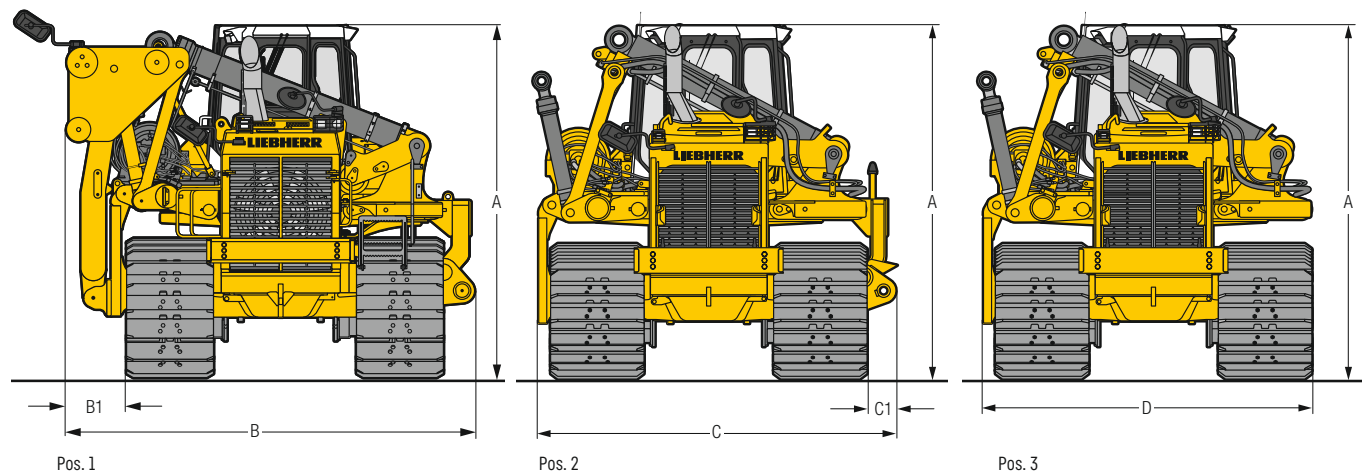

## Transport dimensions

		displayed position
A	Total height	mm / ft-in
B	Overall width	mm / ft-in
B <sub>1</sub>	Width (from console to left track)	mm / ft-in
	Weight (Pos. 1)	kg / lb
C	Overall width	mm / ft-in
C <sub>1</sub>	Width (from console to right track)	mm / ft-in
	Weight (Pos. 2)	kg / lb
D	Overall width	mm / ft-in
	Weight (Pos. 3)	kg / lb



# Lift capacity RL 56 (ISO 8813)

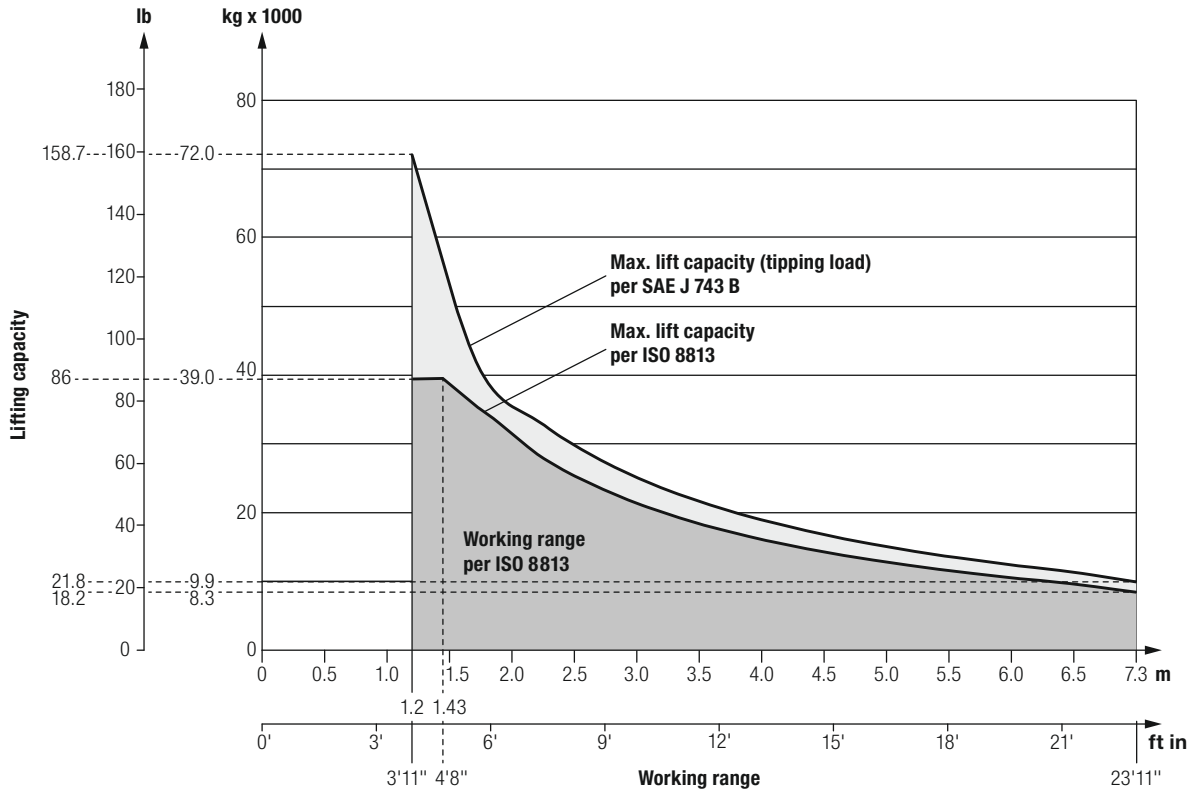

# Ground pressure RL 56 (ISO 8813)

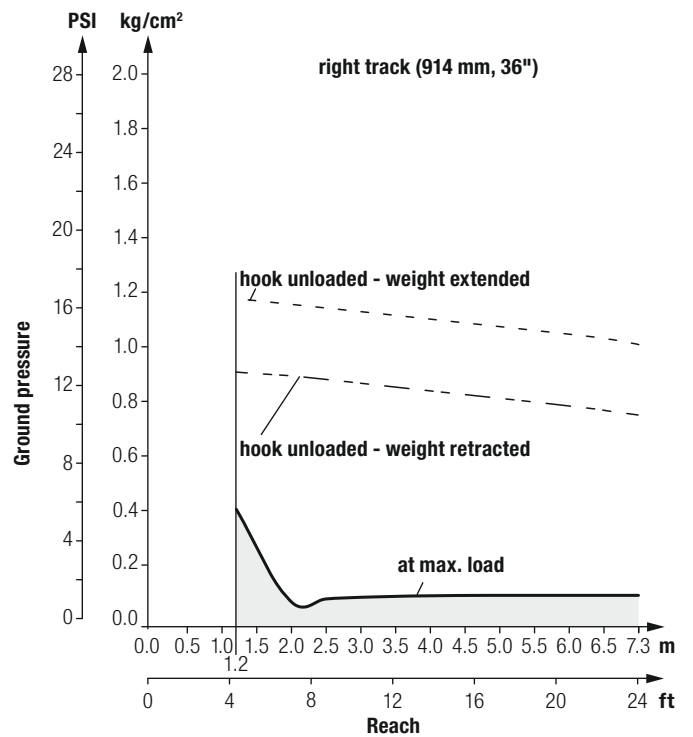
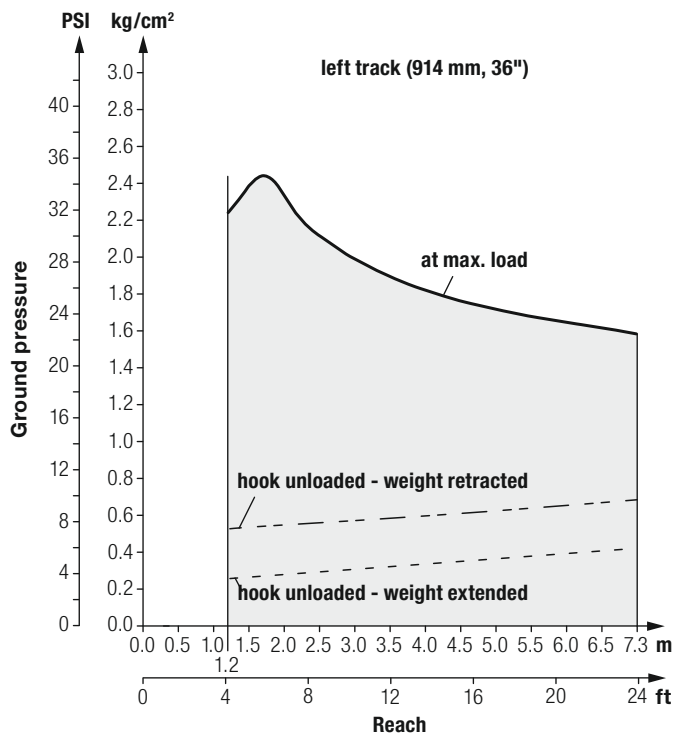

# Technical data RL 66



## Engine

<b>Liebherr Diesel engine</b>	D 946 A7 Emission regulations according to 97/68/EC, 2004/26/EG Stage IIIA/Stage V, EPA/CARB Tier 3 / Tier 4f
<b>Rated power</b> ISO 9249 SAE J1349	275 kW / 374 HP 275 kW / 369 HP
<b>Rated speed</b>	1,800 rpm
<b>Displacement</b>	12 l / 733 in <sup>3</sup>
<b>Design</b>	6 cylinder in-line engine, water-cooled, turbocharged, air-to-air intercooler
<b>Injection system</b>	Direct fuel injection, Common Rail, electronic control
<b>Lubrication</b>	Pressurised lube system, engine lubrication guaranteed for inclinations up to 45°
<b>Operating voltage</b>	24 V
<b>Alternator</b>	140 A
<b>Starter</b>	7.8 kW / 11 HP
<b>Batteries</b>	4 x 95 Ah / 12 V
<b>Air cleaner</b>	Dry-type air cleaner with pre-cleaner, main and safety elements, control light in the operator's cab
<b>Cooling system</b>	Combi radiator, comprising radiators for water and charge air. Hydrostatic fan drive



## Hydraulics

<b>Hydraulic system</b>	Load sensing (demand controlled)
<b>Pump type</b>	Swash plate piston pump
<b>Pump flow max.</b>	283 l/min. / 74.7 gpm
<b>Pressure limitation</b>	280 bar / 4,060 psi
<b>Control valve</b>	3 circuits, expandable to 6
<b>Filter system</b>	Return filter with magnetic rod in the hydraulic tank
<b>Control</b>	Single joystick for hoist winch and adjustable boom cylinder, free all device of hook in case of danger. Further single joystick for counterweight.



## Travel drive, control

<b>Transmission system</b>	Infinitely variable hydrostatic travel drive, independent drive for each track
<b>Travel speed *</b> Speed range 1 (reverse): Speed range 2 (reverse): Speed range 3 (reverse):	Continuously variable 0-4.0 km/h / 2.5 mph (4.8 km/h / 3.0 mph) 0-6.5 km/h / 4.0 mph (7.8 km/h / 4.8 mph) 0-10.5 km/h / 6.5 mph (10.5 km/h / 6.5 mph) *Travel speed ranges can be set on the travel joystick (memory function)
<b>Electronic system</b>	The electronic system automatically adjusts travel speed and drawbar pull to match changing load conditions
<b>Steering</b>	Hydrostatic
<b>Service brake</b>	Hydrostatic (self-locking), wear-free
<b>Parking brake</b>	Multi-disc brake, wear-free, automatically applied with neutral joystick position
<b>Cooling system</b>	Separate oil cooler, hydrostatic fan drive and thermodynamically controlled
<b>Filter system</b>	Micro cartridge filter in the replenishing circuit
<b>Final drive</b>	Combination spur gear with planetary gear, double-sealed (duo cone seals) with electronic seal-integrity indicator
<b>Control</b>	Single joystick for all travel and steering functions



## Operator's cab

<b>Cab</b>	Resiliently mounted cab with positive pressure ventilation, can be tilted with hand pump 40° to the rear. With integrated ROPS Rollover Protective Structure (EN ISO 3471)
<b>Operator's seat</b>	Air suspended comfort seat, fully adjustable
<b>Monitoring</b>	Touch screen: display of current machine information, automatic monitoring of operating conditions, individual setting of machine parameters
<b>Vibration emission</b> Hand / arm vibrations Whole-body vibrations	< 2,5 m/s <sup>2</sup> , according with ISO 5349-1:2001 < 0,5 m/s <sup>2</sup> , complies with technical report ISO/TR 25398:2006
<b>Measuring inaccuracy</b>	According with standard EN 12096:1997

## Undercarriage

<b>Design</b>	Track frame, rigid
<b>Mounting</b>	Separate pivot mit Elastomer
<b>Track chains</b>	Lubricated, single-grouser shoes, tensioning via steel spring and grease tensioner
<b>Links, each side</b>	48
<b>Track rollers, each side</b>	9
<b>Carrier rollers, each side</b>	2
<b>Sprocket segments, each side</b>	5
<b>Track shoes</b>	914 mm / 36"

## Sound levels

<b>Operator sound exposure ISO 6396</b>	
$L_{pA}$ (in the cab)	78 dB(A)
<b>Exterior sound pressure 2000/14/EC</b>	
$L_{WA}$ (to the environment)	108 dB(A)

## Refill capacities

<b>Fuel tank</b>	660l / 174.2 gal
<b>Cooling system</b>	68l / 18.0 gal
<b>Engine oil with filter</b>	43l / 11.4 gal
<b>Splitter box</b>	8,5l / 2.2 gal
<b>Hydraulic tank</b>	129l / 34.1 gal
<b>Final drive, each side</b>	22l / 5.8 gal

## Dawbar pull

<b>Max.</b>	522 kN
<b>at 1.5 km/h / 0.9 mph</b>	522 kN
<b>at 3.0 km/h / 1.9 mph</b>	282 kN
<b>at 6.0 km/h / 3.7 mph</b>	141 kN
<b>at 9.0 km/h / 5.6 mph</b>	94 kN

## Hydraulic winch

<b>Hoist winch</b>	Variable flow hydraulic pump
<b>Safety brake</b>	Spring-loaded disk brake holds the load safely in any position
<b>Drum diameter</b>	254 mm / 10"
<b>Drum length</b>	279 mm / 10.98"
<b>Flange diameter</b>	610 mm / 24.02"
<b>Cable diameter</b>	20 mm / 0.8"
<b>Cable length</b>	100 m / 109.36 yd
<b>Hook block</b>	4 sheaves
<b>Hook speed (up, down)</b>	0-16.0 m/min. / 0-53 ft/min.
<b>Security</b>	Free fall device

# Dimensions and weights RL 66

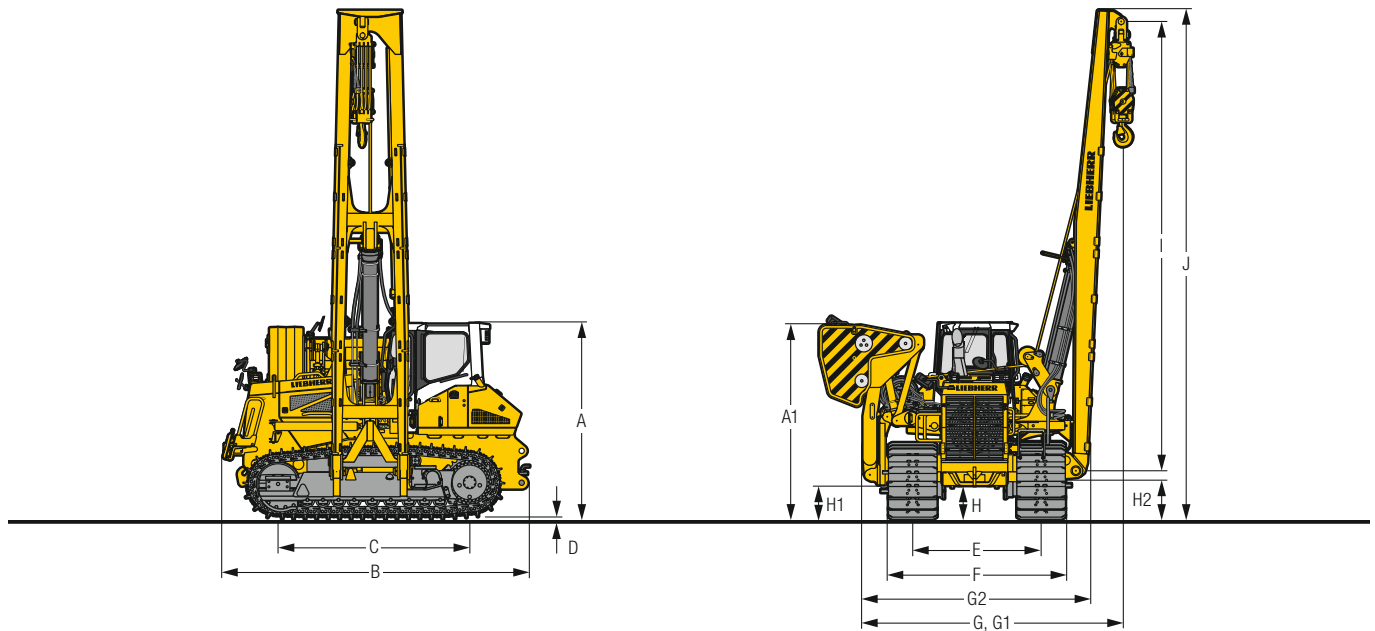

## Dimensions

Boom		Standard 8,500 mm / ft-in	Optional 10,500 mm / ft-in
A	Height over cab	mm / ft-in	3,700 / 12'2"
A <sub>1</sub>	Height over counterweight	mm / ft-in	3,543 / 11'7"
B	Overall length	mm / ft-in	5,795 / 19'
C	Length of track on ground	mm / ft-in	3,610 / 11'10"
D	Height of grousers	mm / ft-in	84 / 3.31"
E	Track gauge	mm / ft-in	2,420 / 7'11"
F	Total width over undercarriage	mm / ft-in	3,348 / 11'
G	Width (counterweight retracted)	mm / ft-in	5,651 / 18'6"
G <sub>1</sub>	Width (counterweight extended)	mm / ft-in	7,291 / 23'11"
G <sub>2</sub>	Width (lower machine area, counterweight folded in)	mm / ft-in	4,245 / 13'11"
H	Ground clearance	mm / ft-in	640 / 2'1"
H <sub>1</sub>	Ground clearance of console	mm / ft-in	754 / 2'6"
H <sub>2</sub>	Ground clearance of boom	mm / ft-in	649 / 2'2"
I	Boom length	mm / ft-in	8,500 / 27'11"
J	Total height	mm / ft-in	9,515 / 31'3"
K	Distance (outer edge of chain link to hook)	mm / ft-in	1,380 / 4'6"
	Operating weight	kg / lb	59,350 / 130,844
	Counterweight without frame	kg / lb	12,000 / 26,455
	Counterweight	kg / lb	15,985 / 35,241
	Weight of standard boom	kg / lb	3,305 / 7,286
			3,854 / 8,497

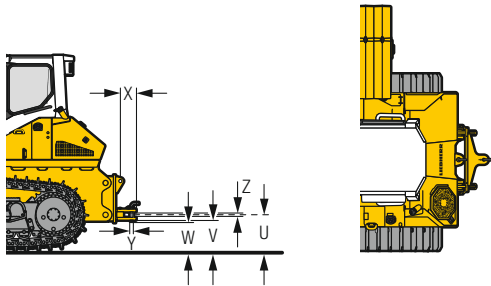

## Drawbar

Boom		rigid	
U	Height of jaw	mm / ft-in	620 / 2'
V	Ground clearance below drawbar	mm / ft-in	517 / 1'8"
W	Ground clearance below drawbar suspension	mm / ft-in	467 / 1'6"
X	Additional length	mm / ft-in	455 / 1'6"
Y	Socket pin diameter	mm / ft-in	60 / 2.36"
Z	Jaw opening	mm / ft-in	105 / 4.13"
	Weight	kg / lb	577 / 1,272

# Transport dimensions and weights RL 66

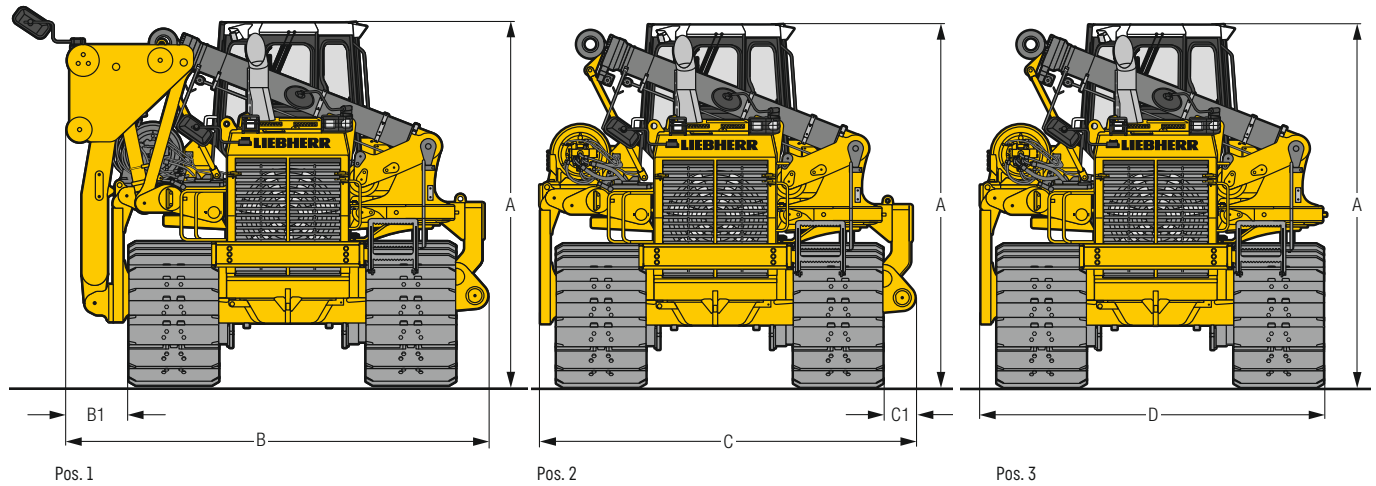

## Transport dimensions

		displayed position
A	Total height	mm / ft-in
B	Overall width	3,700 / 12'2"
B <sub>1</sub>	Width (from console to left track)	mm / ft-in
	Weight (Pos. 1)	4,263 / 13'9"
C	Overall width	mm / ft-in
C <sub>1</sub>	Width (from console to right track)	600 / 1'11"
	Weight (Pos. 2)	43,519 / 95,942
D	Overall width	mm / ft-in
	Weight (Pos. 3)	3,824 / 12'7"
		327 / 12.87"
		40,119 / 88,447
		3,497 / 11'6"
		39,219 / 86,463

# Lift capacity RL 66 (ISO 8813)

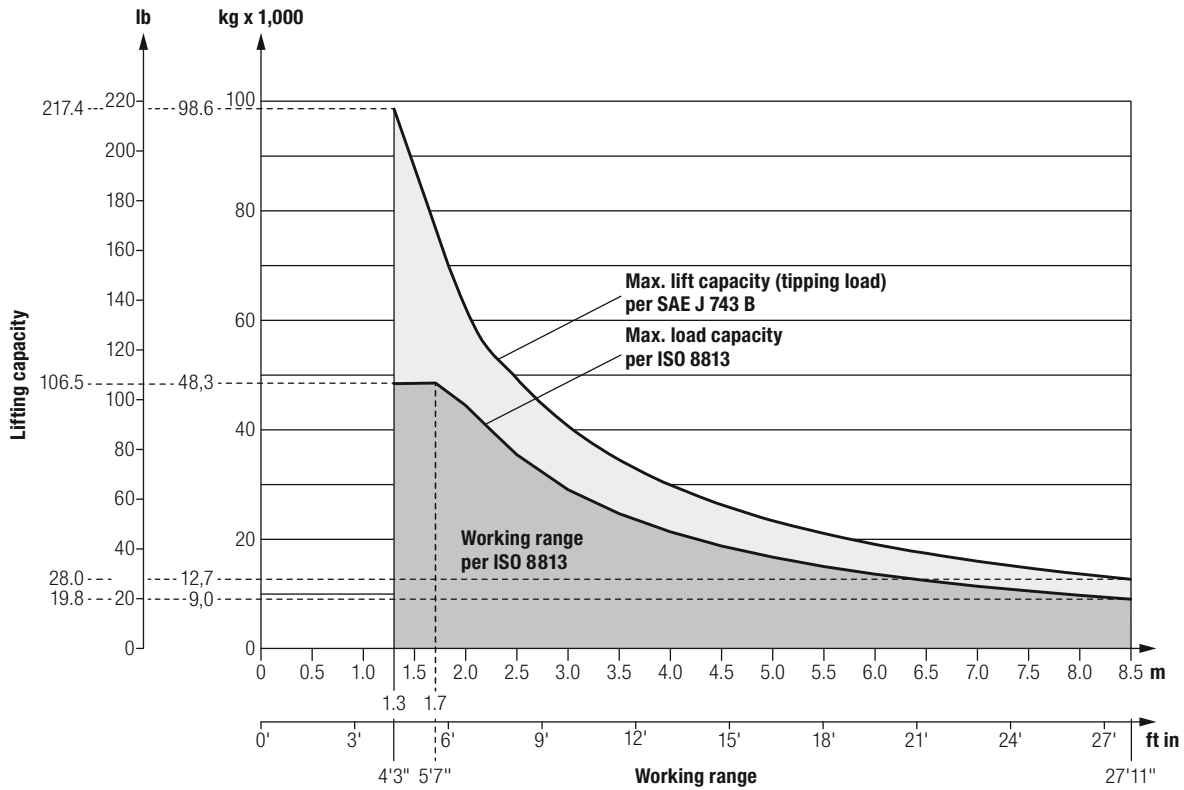

# Ground pressure RL 66 (ISO 8813)

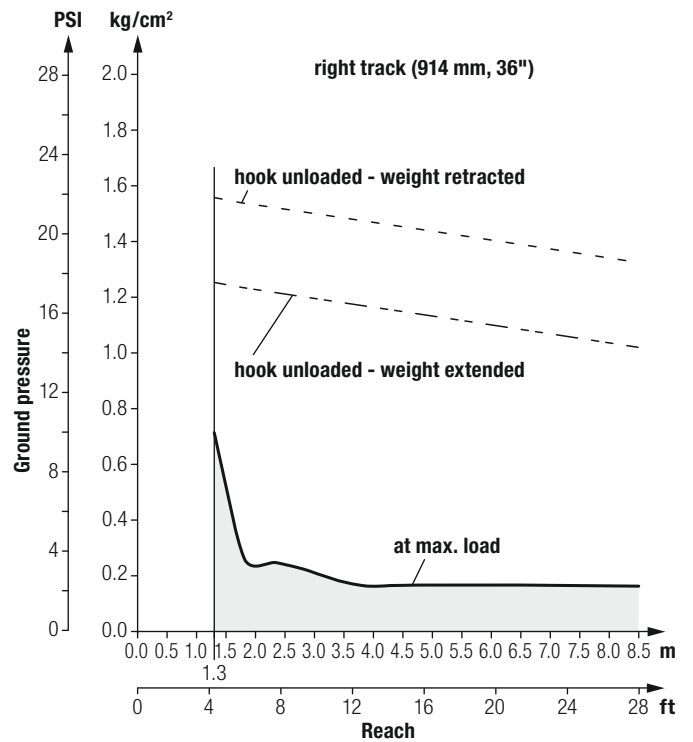
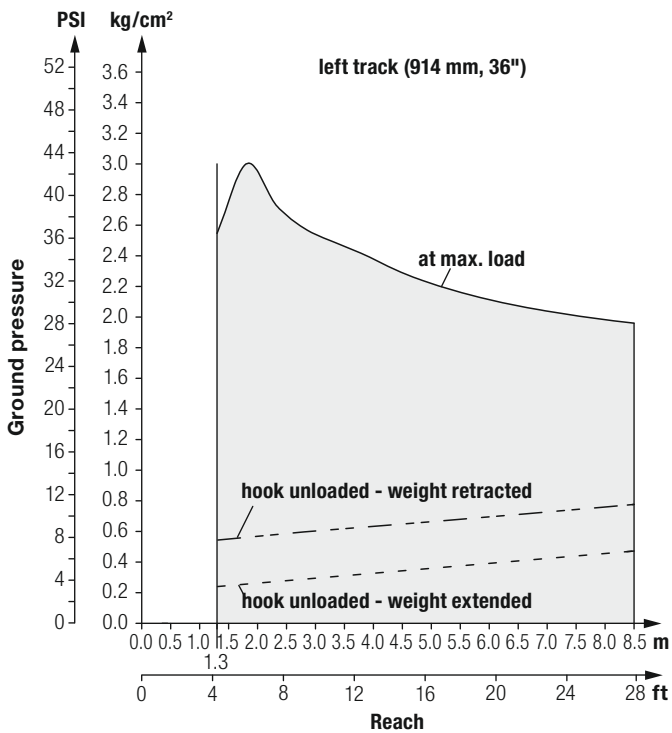

# Equipment



## Base machine

	RL 46	RL 56	RL 66
Access ladder	●	●	●
Air pre-filter Sy-Klone®	+	+	+
Air pre-filter Top Air®	+	+	+
Automatic dust extraction	●	●	●
Battery cold-resistant	●	●	●
Battery container lockable	●	●	●
Battery master switch lockable	+	+	+
Certification Russian customs union	+	+	+
Data transmission interface (e.g. J1939)	1)	1)	1)
DEF tank lockable*	●	●	●
Diesel tank lockable with condensate drain	●	●	●
Engine and battery preheating system	+	+	+
Engine compartment perforated and lockable	●	●	●
Engine emission stage IIIA / Tier 3	●	●	●
Engine emission stage IV / Tier 4f	●	●	●
Enlarged step for cab access	+	+	+
Extended tool kit	+	+	+
Fuel prefilter with water separator heated	+	+	+
Handels tank access additional	+	+	+
Hinged cooling fan front	●	●	●
Hinged cooling fan hydraulic oil rear	-	●	●
Hydraulic oil Liebherr HVI	●	●	●
Hydraulic oil Liebherr Hydraulic Basic 100	+	+	+
Hydraulic oil thermometer	+	+	+
Insulation battery container	+	+	+
Jump-start plug	1)	1)	1)
LiDAT data transmission and fleet management system	+	+	+
Lifting eyes front	●	●	●
Lifting eyes rear	+	+	+
Lubricants cold-resistant	+	+	+
Number plate bracket	+	+	+
Oil level indicator hydraulic oil	+	+	+
Packaging sea transport	+	+	+
Preservation sea transport	+	+	+
Refuelling pump	+	+	+
Reversible fan manually	1)	1)	1)
Spade bracket	1)	1)	1)
Special paint multi colour	1)	1)	1)
Special paint single colour	+	+	+
Tarpaulin engine compartment and cooler	+	+	+
Tow hook front	●	●	●
Warning mark GOST (Russia)	+	+	+



## Travel drive

	RL 46	RL 56	RL 66
3 travel speed ranges	●	●	●
Automatic parking brake	●	●	●
Electronic load limit control	●	●	●
Hydrostatic travel drive	●	●	●
Oil cooler	●	●	●
Planetary gear final drives	●	●	●

## Undercarriage

	RL 46	RL 56	RL 66
Center track guide	+	+	+
Chain master link two-part	●	●	●
Sprocket segments bolted	●	●	●
Track frame closed	●	●	●
Track shoes 710 mm single grouser chamfered	●	-	-
Track shoes 914 mm single grouser chamfered	+	●	●
Track shoes 914 mm single grouser flat	+	+	+
Undercarriage components cold-resistant	●	●	●



## Operator's cab

	RL 46	RL 56	RL 66
Power plug 12 V	●	●	●
270° camera Sky View®	1)	1)	+
Acoustic back-up alarm (deactivatable)	+	+	+
Air Conditioning	●	●	●
Amber beacon	+	+	+
Armrests adjustable	●	●	●
Backrest extension	+	+	+
Blind front window	●	●	●
Blind roof window	1)	1)	1)
Auxiliary cab heating	1)	1)	1)
Cab double glazing	+	+	+
Cab with integrated ROPS	●	●	●
Deactivation of turning on the spot function	+	+	+
Emergency stop	●	●	●
Fire extinguisher	+	+	+
FOPS cab	1)	1)	1)
Free fall device winch	●	●	●
Headlights halogen	●	●	●
Headlights LED	1)	1)	1)
Hoist limit shutoff	●	●	●
Hoop guard travel control	1)	1)	1)
Hoop guard working hydraulics control	●	●	●
Immobilizer electronic	1)	1)	1)
Inch / brake pedal	1)	1)	1)
Individual settings of travel drive response	●	●	●
Joystick control	●	●	●
Liebherr LMB load moment limitation	+	+	+
Maximum travel speed limitation	+	+	+
(Open) seat belt alert	1)	1)	1)
Operator seat Comfort air-suspended	+	+	+
Operator seat Premium air-suspended	+	+	+
Operator seat Standard mechanical	●	●	●
Panorama mirror inside	●	●	●
Radio preparation	●	●	●
Radio standard	+	+	+
Rear view camera	1)	1)	1)
Right and left rear mirrors	+	+	+
Sliding window rear	1)	1)	1)
Sliding window right	+	+	+
Tilttable cab	●	●	●
Touchscreen color display	●	●	●
Windshield wipers all round	●	●	●
Windshield wipers roof window	1)	1)	1)

● = Standard

+ = Option

- = not available

1) On demand

2) Only for stage IV / Tier 4f



# Equipment

 Electrical system	RL 46	RL 56	RL 66
Alternator 140 A	●	●	●
Board voltage 24 V	●	●	●
Cold start batteries 2-4 pieces	●	●	●
Working light right 1 piece	●	●	●
Working lights front 2 pieces	●	●	●
Working lights left 3 pieces	●	●	●
Working lights rear 2 pieces	●	●	●

 Control and warning lights	RL 46	RL 56	RL 66
Display engine coolant temperature	●	●	●
Display fuel level (digital)	●	●	●
Display travel speed ranges	●	●	●
Hydraulic oil thermometer	+	+	+
Indicator light air filter contamination	●	●	●
Indicator light battery charge	●	●	●
Indicator light diesel engine	●	●	●
Indicator light hydraulic oil temperature	●	●	●
Indicator light oil filter contamination	●	●	●
Indicator light parking brake	●	●	●
Indicator light pump replenishing pressure	●	●	●
Oil level indicator hydraulic oil	+	+	+
Operating hours counter (digital)	●	●	●

 Hydraulic system	RL 46	RL 56	RL 66
Pipe rupture protection	●	●	●
Oil filter in hydraulic tank	●	●	●
Pipe protection strips on boom	+	+	+
Variable flow pump, load sensing	●	●	●

 Attachments	RL 46	RL 56	RL 66
Boom 19'8"	●	-	-
Boom 23'11"	-	●	-
Boom 24'	+	-	-
Boom 27'11"	-	+	●
Boom 34'5"	-	-	+
Boom attachment kit cold-resistant	+	+	+
Counterweight cold-resistant	+	+	+
Extended rigid drawbar	+	+	+
Hoist limit shutoff	●	●	●
Hoist rope special length	+	+	+
Hoist rope standard	+	+	+
Hydraulic attachment kit other equipment	1)	1)	1)
Hydraulic attachment kit pipefacing/generator	+	+	+
Hydraulic winch load hook	●	●	●
Lifting cylinder cold-resistant	+	+	+
Mounting plate external equipment	1)	1)	1)
Towing hitch rear	●	●	●
Winch rear	1)	1)	1)

- = Standard
- + = Option
- = not available
- 1) On demand

Options and / or special attachments, supplied by vendors other than Liebherr, are only to be installed with the knowledge and approval of Liebherr in order to retain warranty.

# The Liebherr Group



## Global and independent: more than 70 years of success

Liebherr was founded in 1949. With the development of the world's first mobile tower crane, Hans Liebherr laid the foundations of a successful family business which today comprises more than 140 companies on all continent and employs nearly 51,000 people. The parent company of the Group is Liebherr-International AG in Bulle (Switzerland), whose associates are exclusively members of the Liebherr family.

## Technology leadership and pioneering spirit

Liebherr regards itself as a pioneer. This spirit has enabled the company to make a decisive contribution to the technological history of many industries. Today, employees around the world still share the courage of the company founder to take new paths. They are all united by a passion for technology and fascinating products and the determination to perform outstanding work for their customers.

## Widely diversified product portfolio

Not only is Liebherr one of the biggest construction equipment manufacturers in the world, it also provides high-quality, user-oriented products and services in a wide range of other areas. The product portfolio includes the segments earthmoving, material handling technology, deep foundation machines, mining, mobile and crawler cranes, tower cranes, concrete technology, maritime cranes, aerospace and transportation systems, gear technology and automation systems, refrigeration and freezing, components and hotels.

## Customized solutions and maximum customer benefit

Liebherr solutions are characterized by maximum precision, outstanding implementation and exceptional longevity. Its mastery of key technologies enables the company to offer its customers customized solutions. For Liebherr, customer focus does not end with the product; it also encompasses a wide range of services that make a real difference.

[www.liebherr.us](http://www.liebherr.us)

### **WARNING**

Breathing diesel engine exhaust exposes you to chemicals known to the State of California to cause cancer and birth defects or other reproductive harm.

- Always start and operate the engine in a well-ventilated area.
- If in an enclosed area, vent the exhaust to the outside.
- Do not modify or tamper with exhaust system.
- Do not idle the engine except as necessary.

For more information go to [www.P65warnings.ca.gov/diesel](http://www.P65warnings.ca.gov/diesel).

### **WARNING**

This product can expose you to chemicals including lead and lead compounds, which are known to the State of California to cause cancer and birth defects or other reproductive harm.

For more information go to [www.P65warnings.ca.gov](http://www.P65warnings.ca.gov).

## Liebherr-Werk Telfs GmbH

Hans-Liebherr-Straße 35 • 6410 Telfs, Austria • Phone +43 50809 6-100 • Fax +43 50809 6-7772  
[lwt.marketing@liebherr.com](http://lwt.marketing@liebherr.com) • [www.liebherr.com](http://www.liebherr.com) • [www.facebook.com/LiebherrConstruction](http://www.facebook.com/LiebherrConstruction)