

EN

HSG 5-18

Hydraulic slurry wall grab
www.liebherr.com

LIEBHERR

Deep foundation machines



Characteristics

Basic machine HS 8100.1 with hydraulic slurry wall grab HSG 5-18

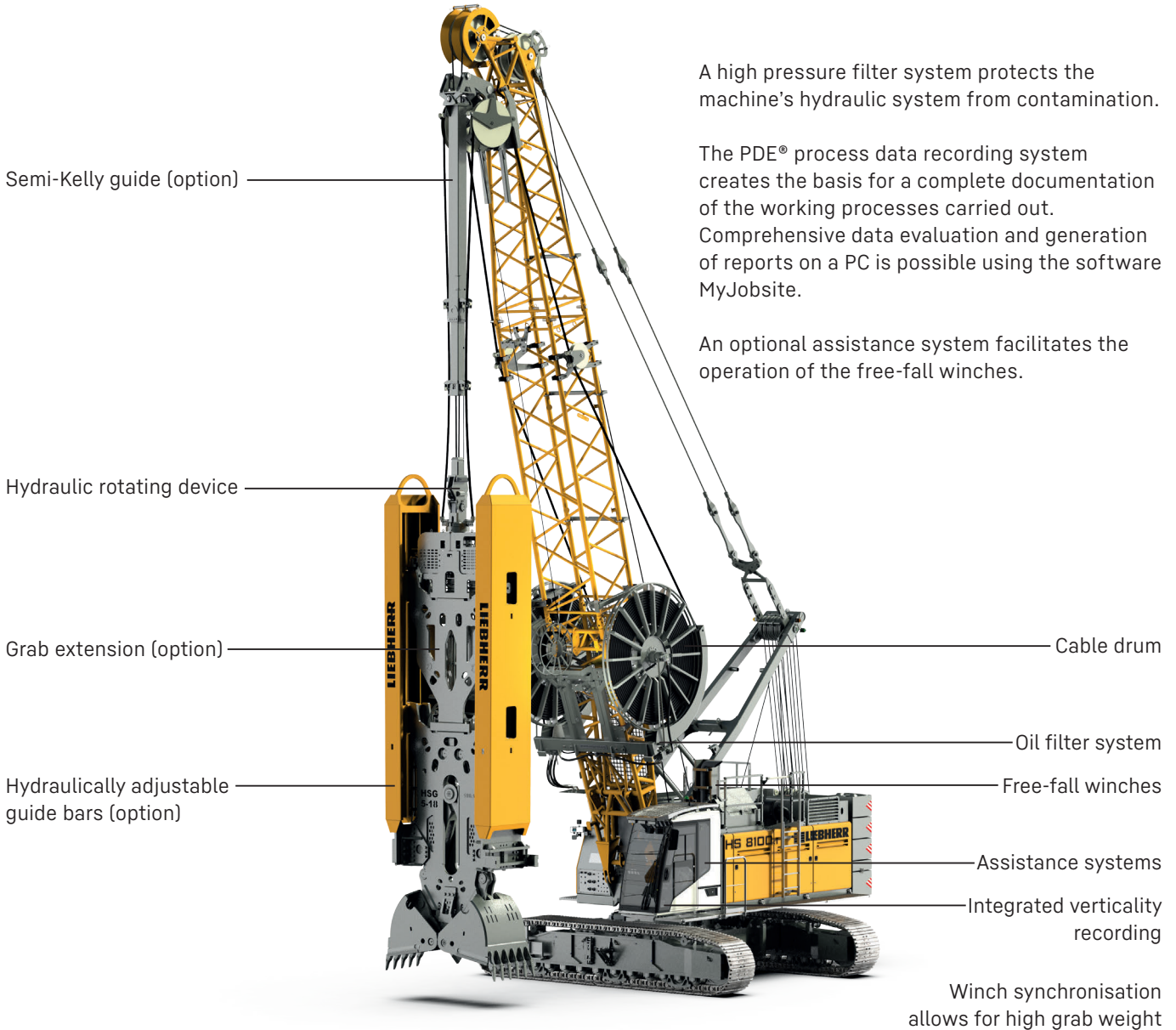

Features of the HSG 5-18 slurry wall grab

The modular design of the grab promises a high level of flexibility and enables the optimum adaptation to jobsite requirements.

The hydraulic slurry wall grab package is based on the proven HS series. It unites precision, power and economy. At the same time the multifunctionality of the carrier machine is maintained 100%.

The grab convinces with its robust design and high closing force. These properties provide a decisive advantage especially for hard soil conditions.

Thanks to the synchronisation of the hoisting winches high grab weights are viable and the lifting capacity of the basic machine is optimally utilized. As a standard the free-fall winches are also synchronised and can be controlled using a pedal.

Dimensions

Basic machine HS 8100.1 with hydraulic slurry wall grab HSG 5-18

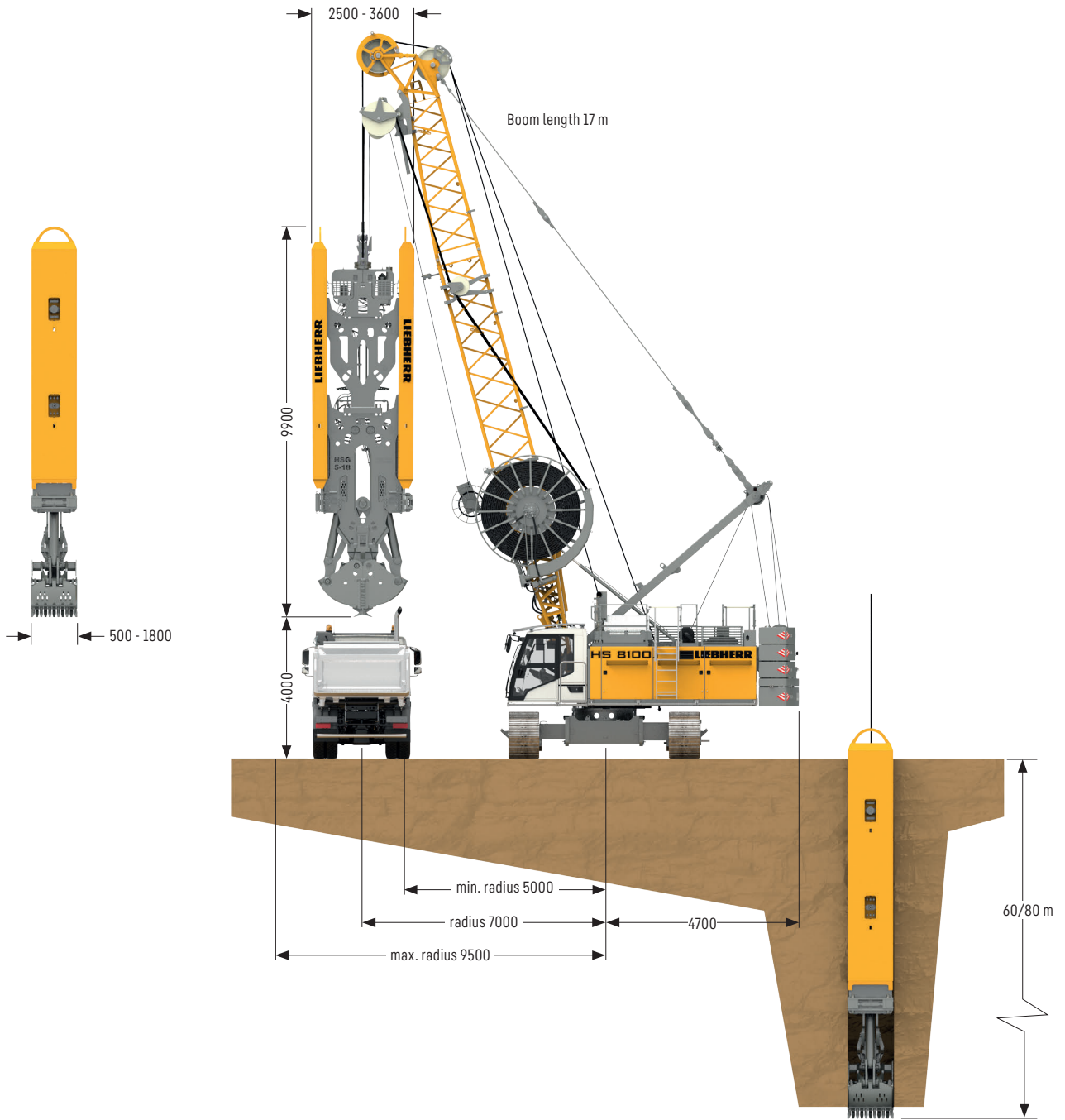

Overview carrier machines



HS 8070.1

Technical data

Engine power	kW	320
2x free-fall winches (line pull 1 st layer)	kN	200
Rope diameter	mm	30
Effective rope length	m	145
Max. admissible line pull in 2-rope operation	kN	300
Max. admissible weight of mech. slurry wall grab (full)	t	20
Max. recommended weight of hydr. slurry wall grab (full)	t	23



HS 8100.1

Technical data

Engine power	kW	390
2x free-fall winches (line pull 1 st layer)	kN	275
Rope diameter	mm	34
Effective rope length	m	141
Max. admissible line pull in 2-rope operation	kN	417
Max. admissible weight of mech. slurry wall grab (full)	t	27.5
Max. recommended weight of hydr. slurry wall grab (full)	t	30



HS 8130.1

Technical data

Engine power	kW	565
2x free-fall winches (line pull 1 st layer)	kN	350
Rope diameter	mm	36
Effective rope length	m	233
Max. admissible line pull in 2-rope operation	kN	530
Max. admissible weight of mech. slurry wall grab (full)	t	35
Max. recommended weight of hydr. slurry wall grab (full)	t	40

Transport dimensions and weights

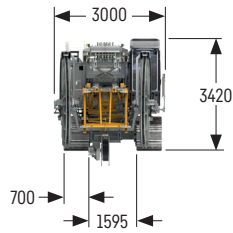
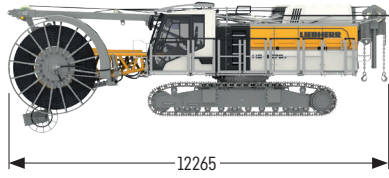

Carrier machine HS 8070.1, crawlers non-detachable

with HD undercarriage, boom foot (1311.24), A-frame, 2x 200kN winches, without rear counterweight

Width with 700 mm 3-web grousers	mm	3000
Weight with 700 mm 3-web grousers	kg	45900
Width with 800 mm 3-web grousers	mm	3400
Weight with 800 mm 3-web grousers	kg	46800
Width with 900 mm 3-web grousers	mm	3500
Weight with 900 mm 3-web grousers	kg	48600
Weight of hoist ropes	kg/m	4.62

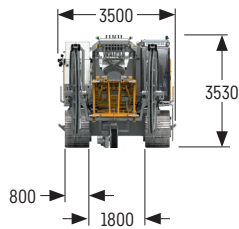
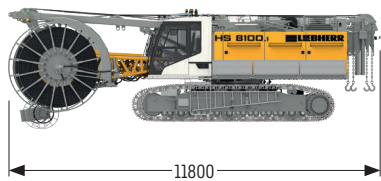

Carrier machine HS 8100.1

with HD undercarriage, boom foot (1311.24), A-frame, 2x 275 kN winches including wire ropes (90 m), without rear counterweight

Width	mm	3500
Weight with 800 mm 3-web grousers	kg	59550
Weight with 900 mm 3-web grousers	kg	59930
Weight of hoist ropes (2x 90 m)	kg/m	5.68

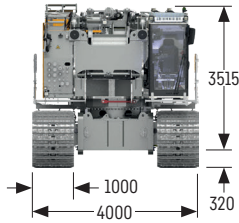
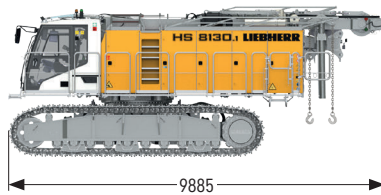

Carrier machine HS 8130.1, crawlers detachable

with HD undercarriage, A-frame, 2x 350 kN winches and self-assembly system for rear counterweight, without boom foot and rear counterweight - fully tanked and ready for operation

Width	mm	4000
Weight without hoist ropes	kg	78000
Weight of hoist ropes (2x 90 m)	kg/m	6.5
Width without crawlers	mm	3500
Weight without crawlers	kg	51000

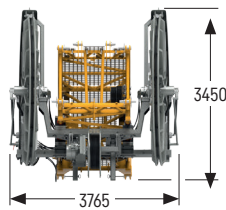
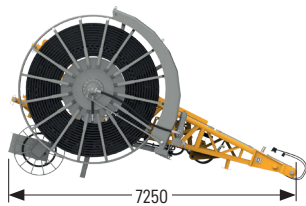

Boom foot (7 m) HS 8130.1

Width	mm	3765
Weight incl. hose drum and 75 m of hydraulic hose without oil	kg	7310

Grab sizes

HSG 5-18 C/L

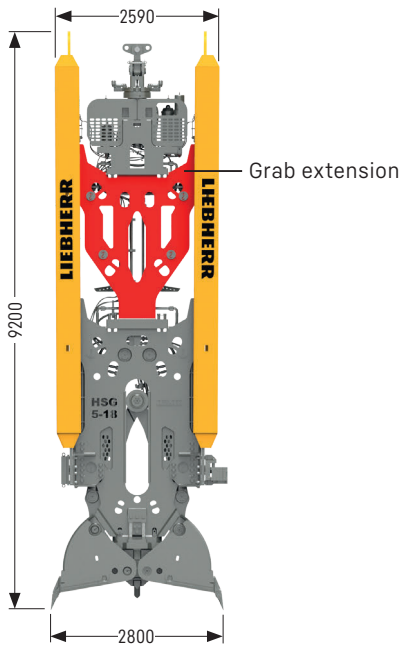

HSG 5-18 L

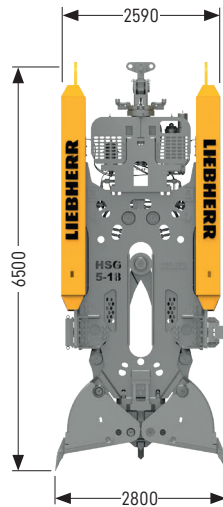

HSG 5-18 C

The grab extension increases weight and length of the grab and therefore enhances the verticality of the trench. The extension is recommended for deep trenches.

Example dimensions of HSG 5-18 C/L for jaw opening width of 2800 mm.

Different opening widths result in different dimensions.

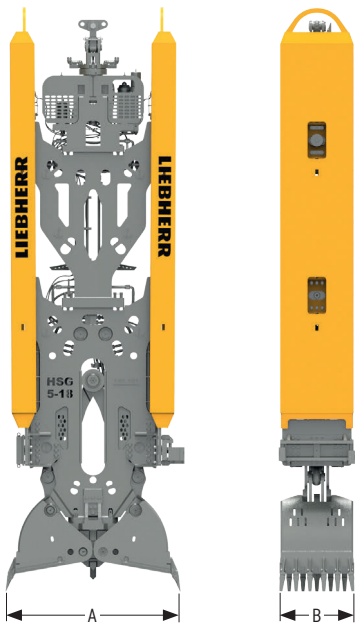

Other jaw opening widths on request.

Technical data HSG 5-18 C/L

Jaw opening width	Slurry wall thickness	Grab capacity	Grab weight empty		Grab weight full	
			HSG C	HSG L	HSG C	HSG L
A	B	[m ³]	[t]	[t]	[t]	[t]
[mm]	[mm]					
2800	500	0.62	13.2	16.8	14.4	18.0
	600	0.78	13.6	17.2	15.2	18.8
	800	1.10	15.2	19.1	17.4	21.3
	1000	1.42	16.4	20.5	19.2	23.3*
	1200	1.72	16.9	21.5	20.3	24.9*
	1500	2.21	18.8	23.3	23.2*	27.7*
3200	1800	2.69	20.3	25.1	25.7*	30.5**
	500	0.79	13.9	17.5	15.5	19.1*
	600	0.99	14.4	18.0	16.4	20.0*
	800	1.39	16.0	19.9	18.8	22.7*
	1000	1.80	17.2	21.2	20.8	24.8*
	1200	2.20	17.7	22.3	22.1	26.7*
3400	1500	2.81	19.6	24.1	25.2*	29.7*
	1800	3.41	21.0	25.9	27.8*	32.7**
	500	0.93	14.3	17.9	16.2	19.8
	600	1.16	14.8	18.4	17.1	20.7
	800	1.64	16.5	20.4	19.8	23.7*
	1000	2.12	17.7	21.8	21.9	26.0*
	1200	2.59	18.3	22.9	23.5*	28.1*
	1500	3.30	20.2	24.7	26.8*	31.3**
	1800	4.02	21.7	26.5	29.7*	34.5**

* Permissible on carrier machine HS 8100.1 and HS 8130.1

** Permissible on carrier machine HS 8130.1

The given weights can vary with the final configuration of the machine.

Modular design

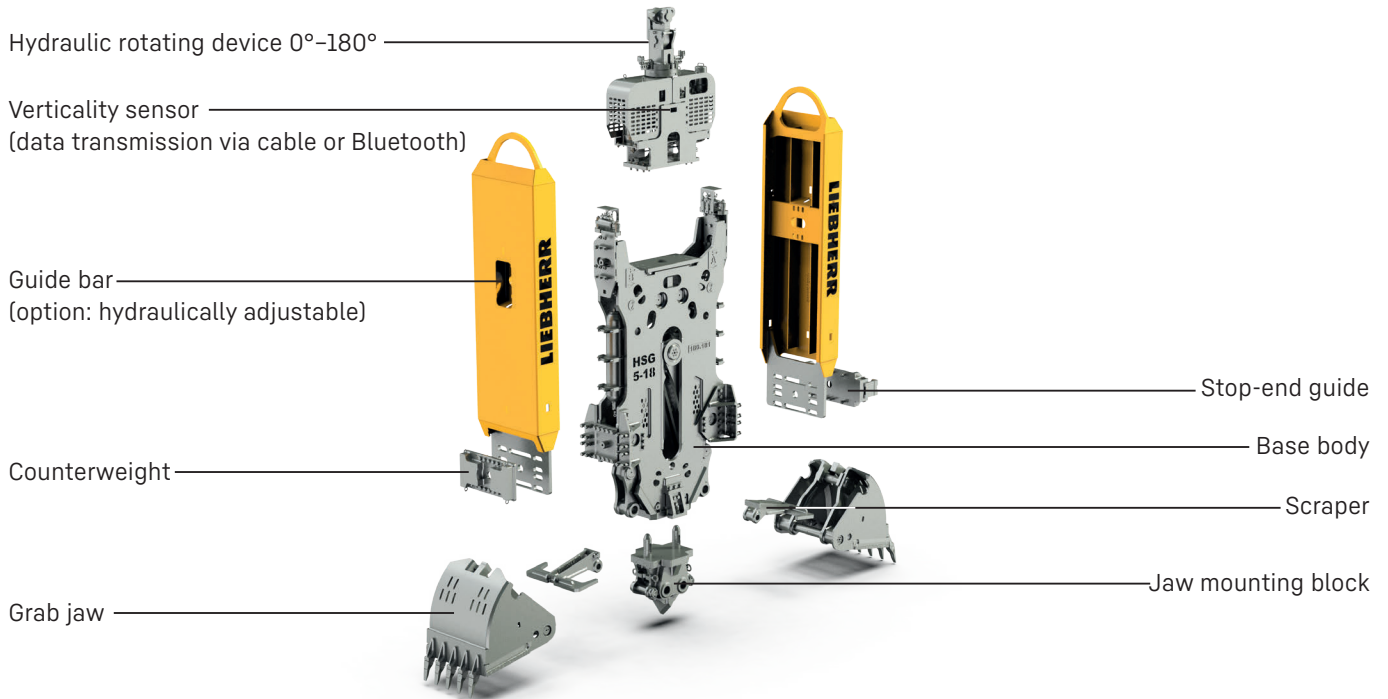

Grab closing mechanism

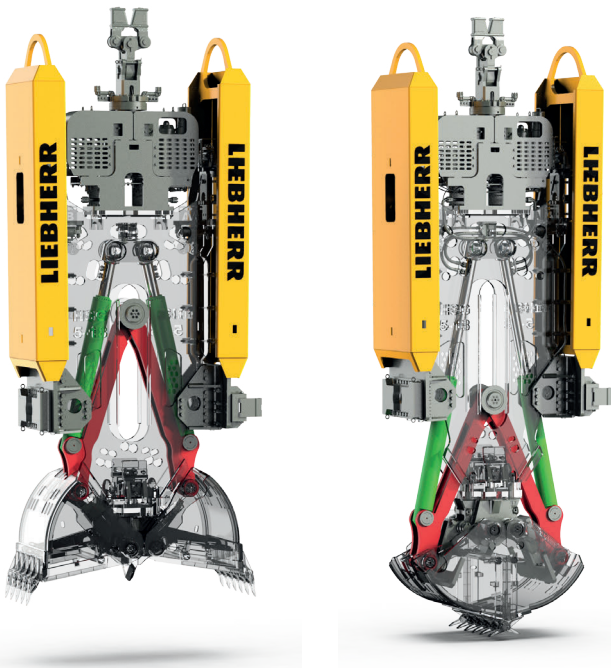

Opening and closing of the grab is actuated by two direct-acting cylinders. These are installed with the piston rods at the top, which means they are protected inside the grab body. The robust cylinder barrels are positioned downwards.

Synchronised opening or closing of the grab jaws is mechanically ensured via push rods. This mechanism is reliable and easy to maintain.

Cylinder 180/140 (standard)	bar	300
Cylinder force (2 cylinders)	kN	1527
Max. closing force at teeth (2800 mm)	kN	948
Opening/closing speed	sec	8.9

Cylinder 200/140 (option)	bar	300
Cylinder force (2 cylinders)	kN	1885
Max. closing force at teeth (2800 mm)	kN	1170
Opening/closing speed	sec	11

Semi-Kelly guide (option)



With semi-Kelly guide

The optional semi-Kelly guide provides for steady guidance of the grab outside the trench. This makes rotation and alignment of the grab easier for the operator and accelerates the process.



Without semi-Kelly guide

Operating the grab without the optional semi-Kelly guide increases the basic machine's flexibility. Quick conversion for operation with mechanical grab, as a lifting crane, or for chisel application is possible. Another advantage compared to the semi-Kelly version is the lower weight on the boom.

Hydraulic rotating device

Hydraulic
rotating device

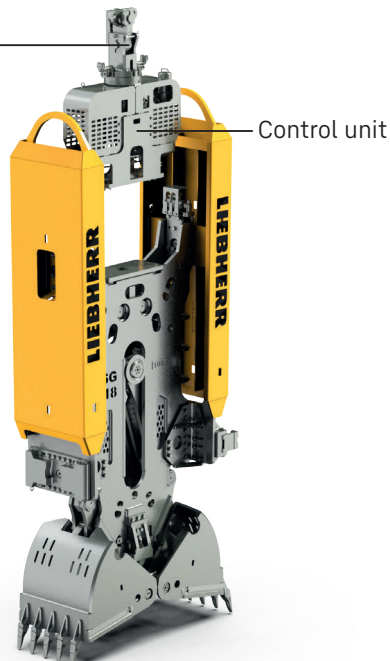

Control unit

The rotating device allows for easy rotation and alignment of the grab after each grab cycle.

Advantages of the rotating device

- Alignment of the grab in slurry wall direction, rotation range 2x 180°
- Storing of the grab position
- Rotation from 0° to 180° after each grab cycle

Signal and data transmission via radio

Control and sensor signals are transmitted via radio outside the trench.

Signal and data transmission via cable (option)

Control and sensor signals are transmitted via cable. If the cable is damaged, limited operation via radio is possible.

Adjustable guide bars (option)

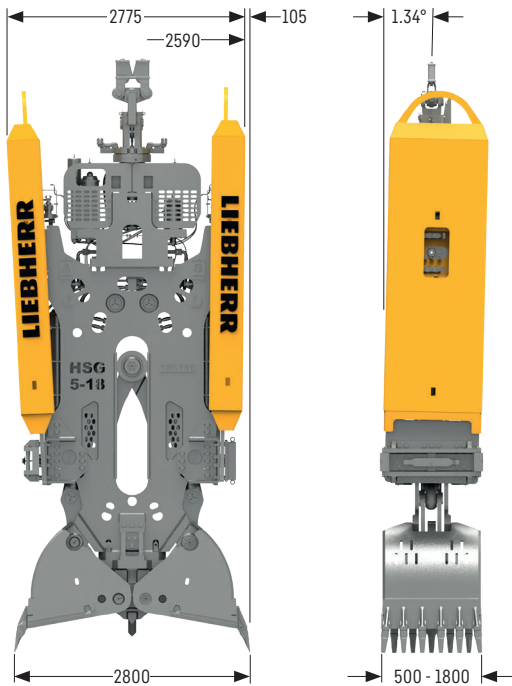

During excavation work the grab direction can be corrected using the guide bars and so higher verticality of the slurry wall is achieved. The system is driven hydraulically and can be controlled from the cabin.

In combination with the cable drum the guide bars can also be adjusted in the trench. The position of the guide bars is shown on the display.

Example dimensions of HSG 5-18 C for jaw opening width of 2800 mm. Different opening widths result in different dimensions.

Additional weight (option)

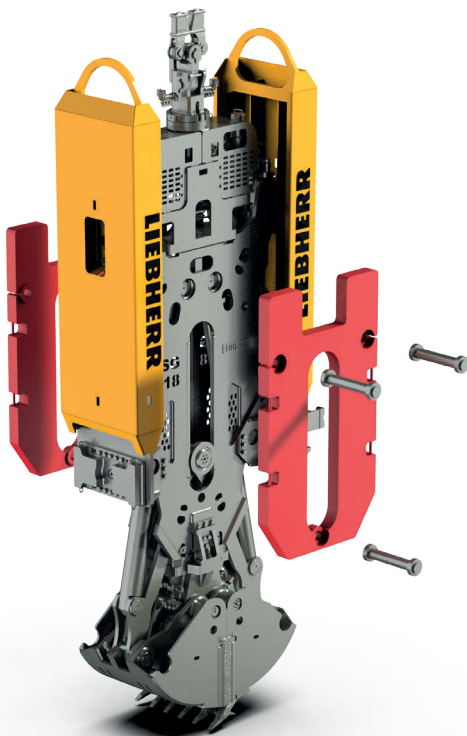

Additional weight of 4.4 t or 6.5 t is available.

Stop-end guide (option)

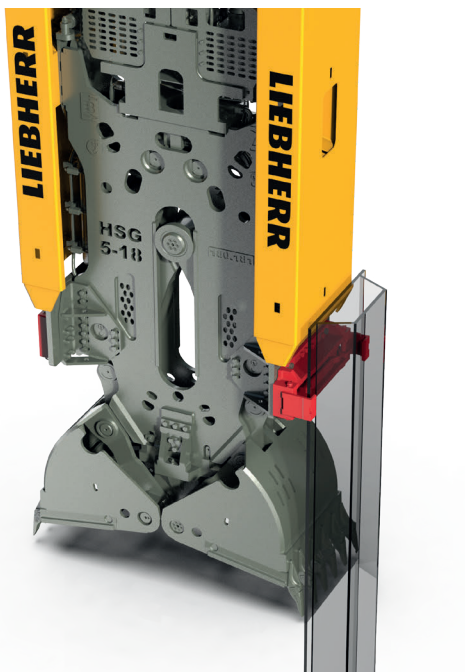

The slurry wall grab is guided vertically along the stop-end element via the stop-end guide. Furthermore, this guide serves to scrape off and loosen the excess/seeping concrete from the stop-end element.

Accumulator for accelerated opening (option)

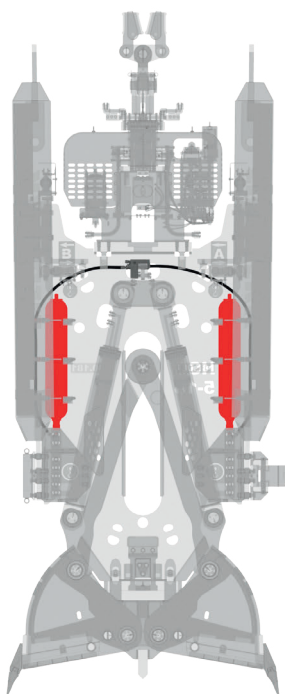

These additionally installed accumulators temporarily store the high oil flow that occurs when the jaws are opened. As a result, high closing speeds can be achieved despite generously dimensioned closing cylinders.

The actual closing speeds that can be achieved depend on the size of the grab jaws and the cylinder installed.

Verticality assistant

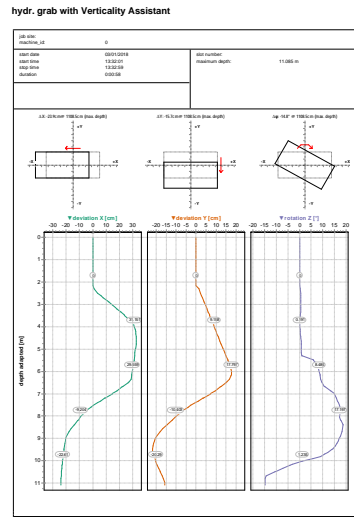
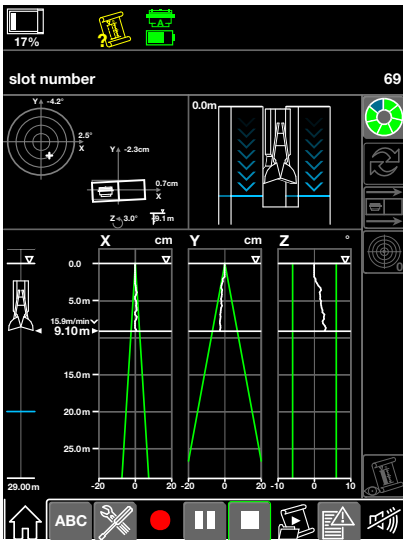

Verticality assistant for hydraulic and mechanical slurry wall grabs

This assistance system is fully integrated in the Liebherr machine's control and process data recording system. It supports and records the slurry wall installation process. With the help of the verticality assistant deviations in the slurry wall along the X and Y axes, as well as the rotation round the Z axis are measured.

- Visualization of the measurements for the machine operator
- Two possible solutions for data transmission: Bluetooth transmission between sensor on the grab and receiver in the uppercarriage (delayed data visualization) or real-time transmission via cable
- Optimum support for the machine operator through an innovative, graphic control system in order to carry out successful measurements
- Ensures optimum measuring conditions by automatically limiting the hoisting speed with two options (exact slow or accelerated measuring run)
- Simple guidelines for calibrating the verticality measuring system
- Mobile data transfer via the telematics system from the machine to the reporting software in the office (MyJobsite)

This system allows control of the precision for the whole depth of the trench. Reports can also be created in MyJobsite for the whole slurry wall installation process. These enable traceability of the application and proof of quality.

Notes

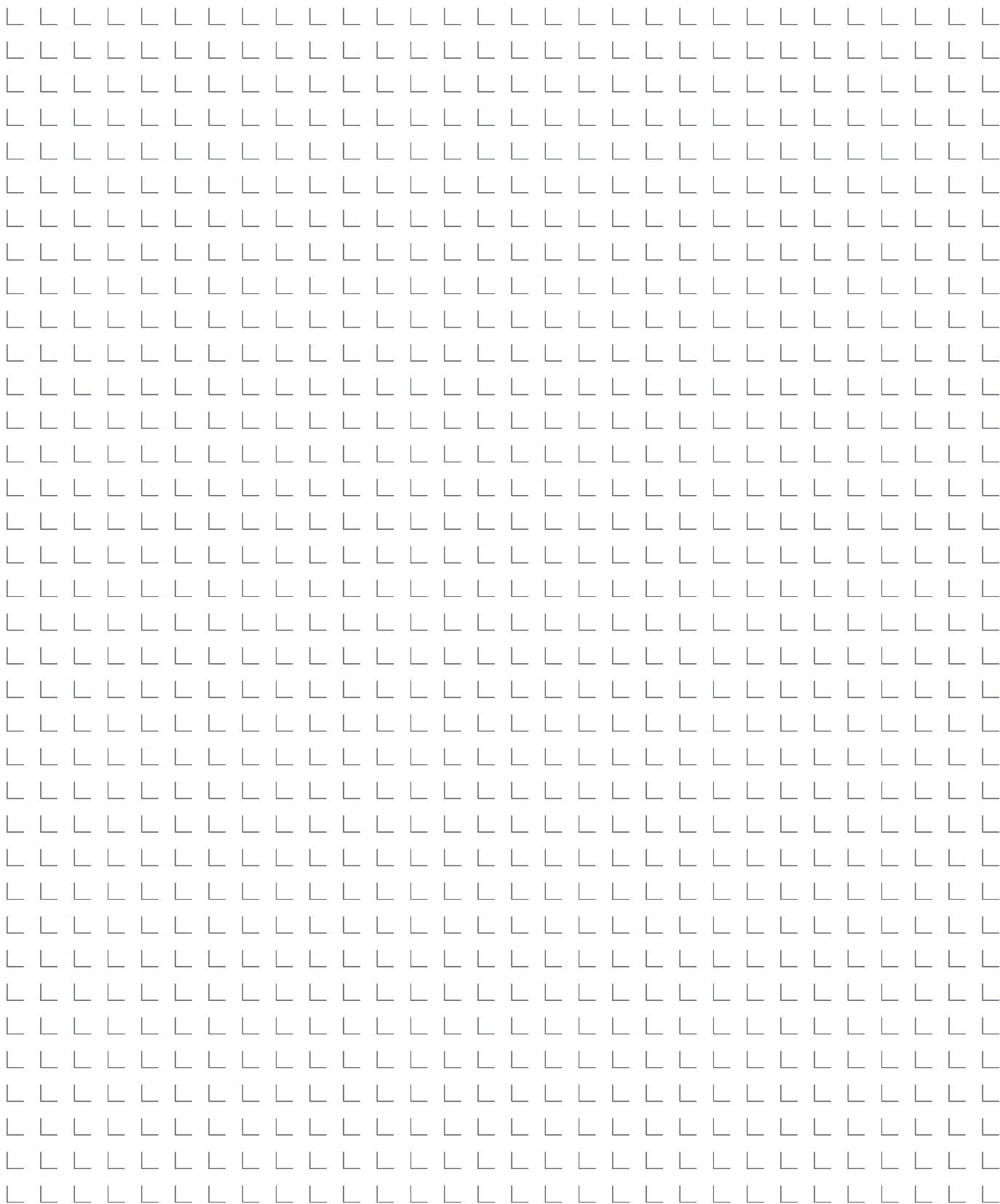

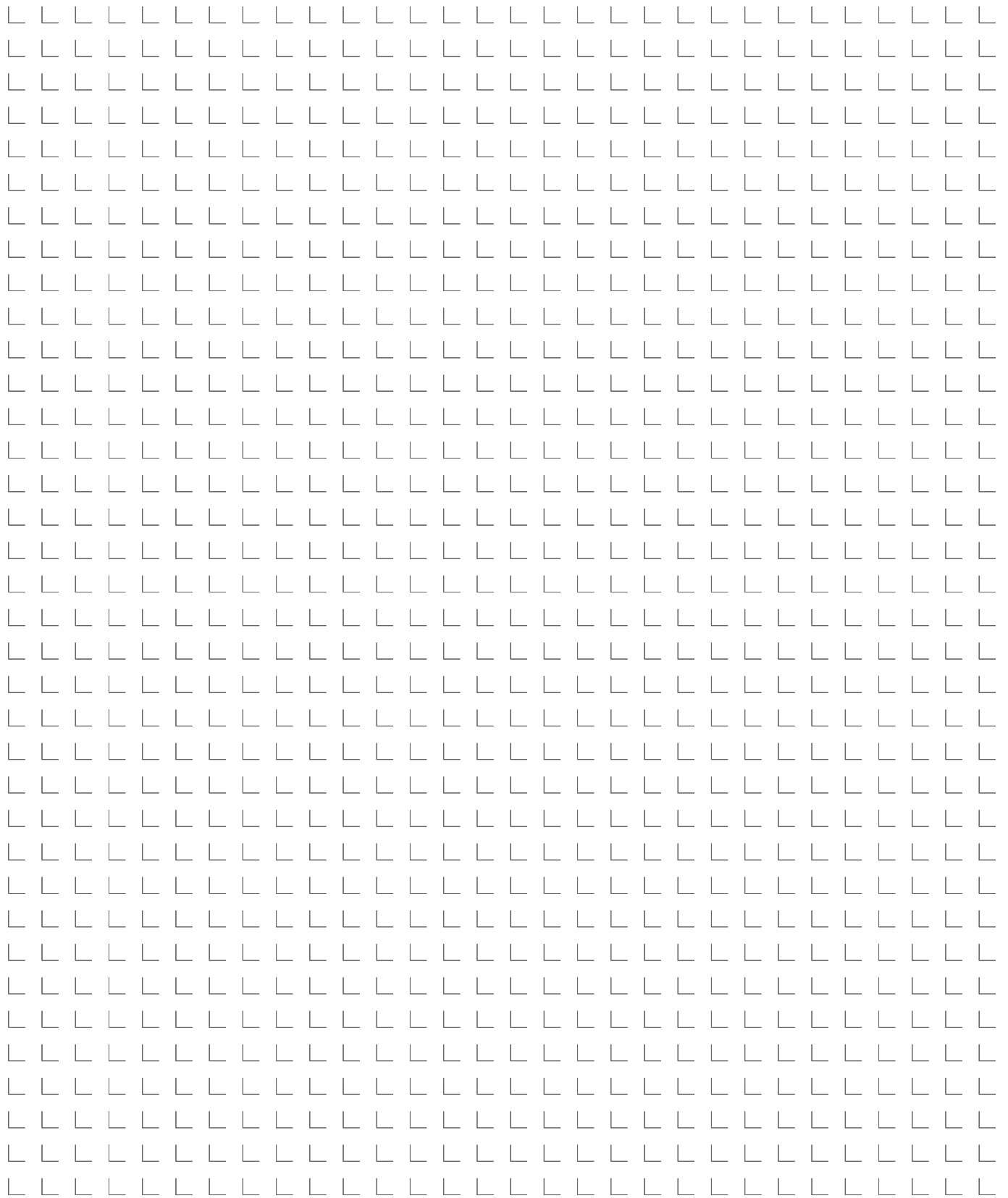

Liebherr-Werk Nenzing GmbH · Dr. Hans Liebherr Str. 1 · 6710 Nenzing, Austria
Phone +43 50809 41-473 · crawler.crane@liebherr.com · www.liebherr.com
facebook.com/LiebherrConstruction